

# Dielectric tests during installation and commissioning of VAMP protection relays



## User qualification

Electrical equipment should be installed, operated, serviced, and maintained only by trained and qualified personnel. No responsibility is assumed by Schneider Electric for any consequences arising out of the use of this material. A qualified person is one who has skills and knowledge related to the construction, installation, and operation of electrical equipment and has received safety training to recognize and avoid the hazards involved.



## Insulation and dielectric strength testing

Insulation testing may leave capacitors charged up to a hazardous voltage. At the end of each part of the test, the voltage should be gradually reduced to zero, to discharge capacitors, before the test leads are disconnected.

## 1 Introduction

The dielectric voltage withstand test is an integral part of the product safety evaluation of electrical and electronic devices, and provides manufacturers with important information regarding the quality and appropriateness of the chosen insulation system. The test involves placing an extra-high voltage across the insulation barrier of the device for one minute. If the insulation holds the voltage, the device is deemed to have passed the test. However, if the applied voltage leads to the sudden breakdown of the insulation material and allows current to flow, the insulation is determined to be insufficient since it might pose a shock hazard to users.

Vamp protection relays are tested according to IEC 60255-27 class III which applies to protection relays connected to:

- a) The auxiliary energizing circuits of the relay are connected to a common battery and/or, due long lead lengths, common mode transient voltages of a relatively high value may appear on the supply leads and differential mode voltages may arise from switching in other circuits connected to the same battery or supply source
- b) The input energizing circuits of the relay are connected to current and voltage transformers
- c) The output contacts are connected to a load by long leads, with the result that common mode transient voltages of a relative high value may appear at the output terminals

At the factory the tests are carried out following way:

- a) Between each circuit and the exposed conductive parts, the terminals of each independent circuit being connected together
- b) Between independent circuits, the terminals of each independent circuit being connected together

Independent circuits are described in this manual.

Generally Vamp relays rated insulation voltage is <300Vac which leads to production test voltage of 2kVac but there are exceptions explained later in this document.

According to IEC 60255-27 repetition of the dielectric test for measuring relays and protection equipment in a new condition may be repeated, if necessary, to verify their performance. The test voltage value shall be equal to 0.75 times the value originally specified by manufacturer. In case of 2kVac, this means 1.5kVac.

## 2 Description of the test setup

Isolate all wiring from the earth and connect terminals of the same circuits together temporarily.

The main groups of relay terminals are:

- Auxiliary voltage supply input
- Current transformer channels
- Voltage transformer channels
- Digital inputs
- Digital outputs
- Relay outputs
- Case earth
- Communication ports
- Analog outputs (mA output)

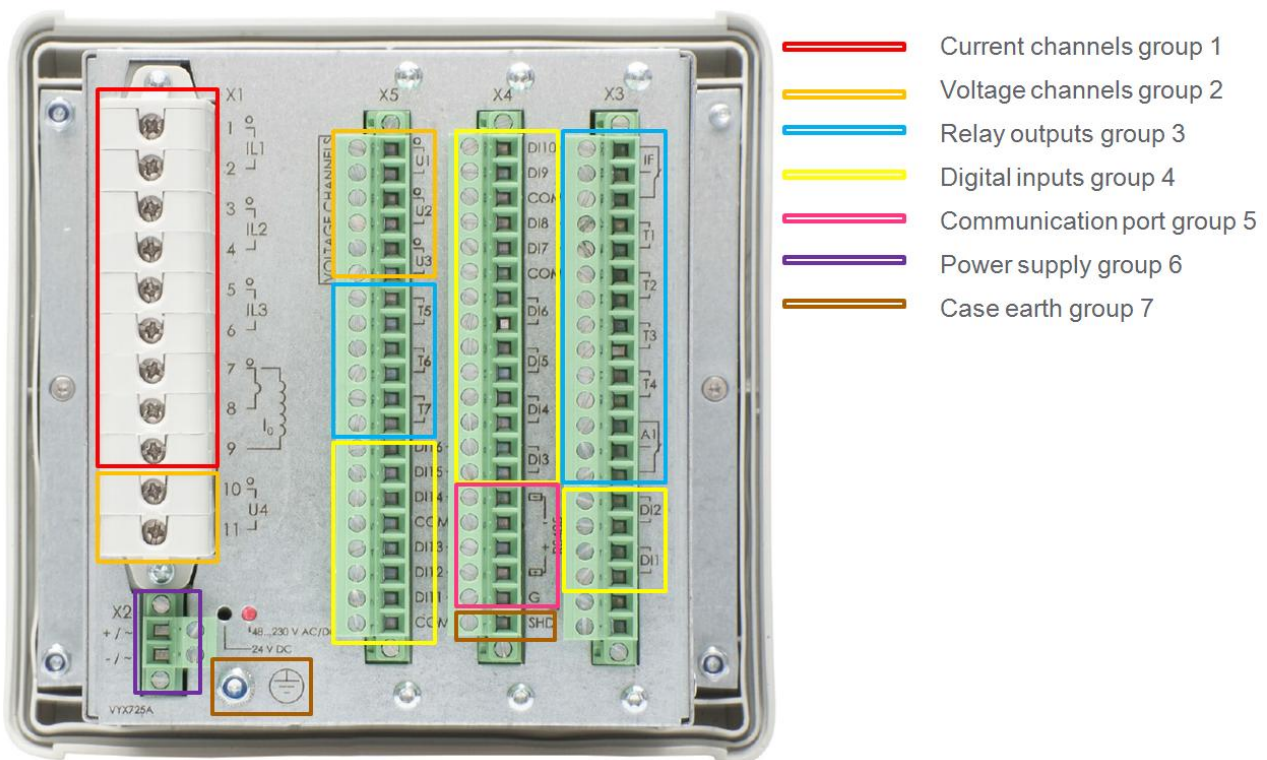

Figure 1. Example of the groups in V57 relay.

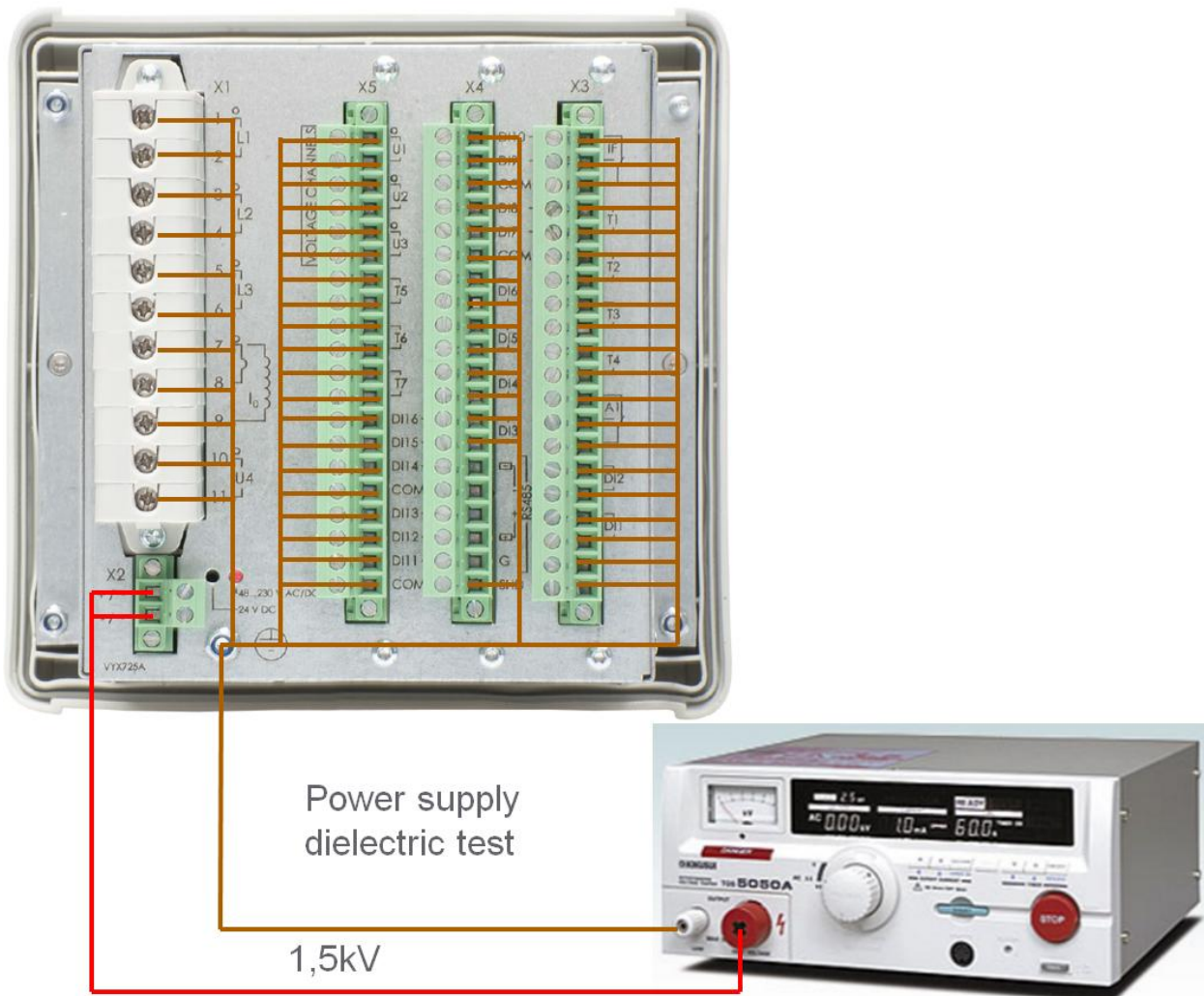

Figure 2. Dielectric test for power supply.

**Note! RS485 port is not connected during 1.5kV test.**

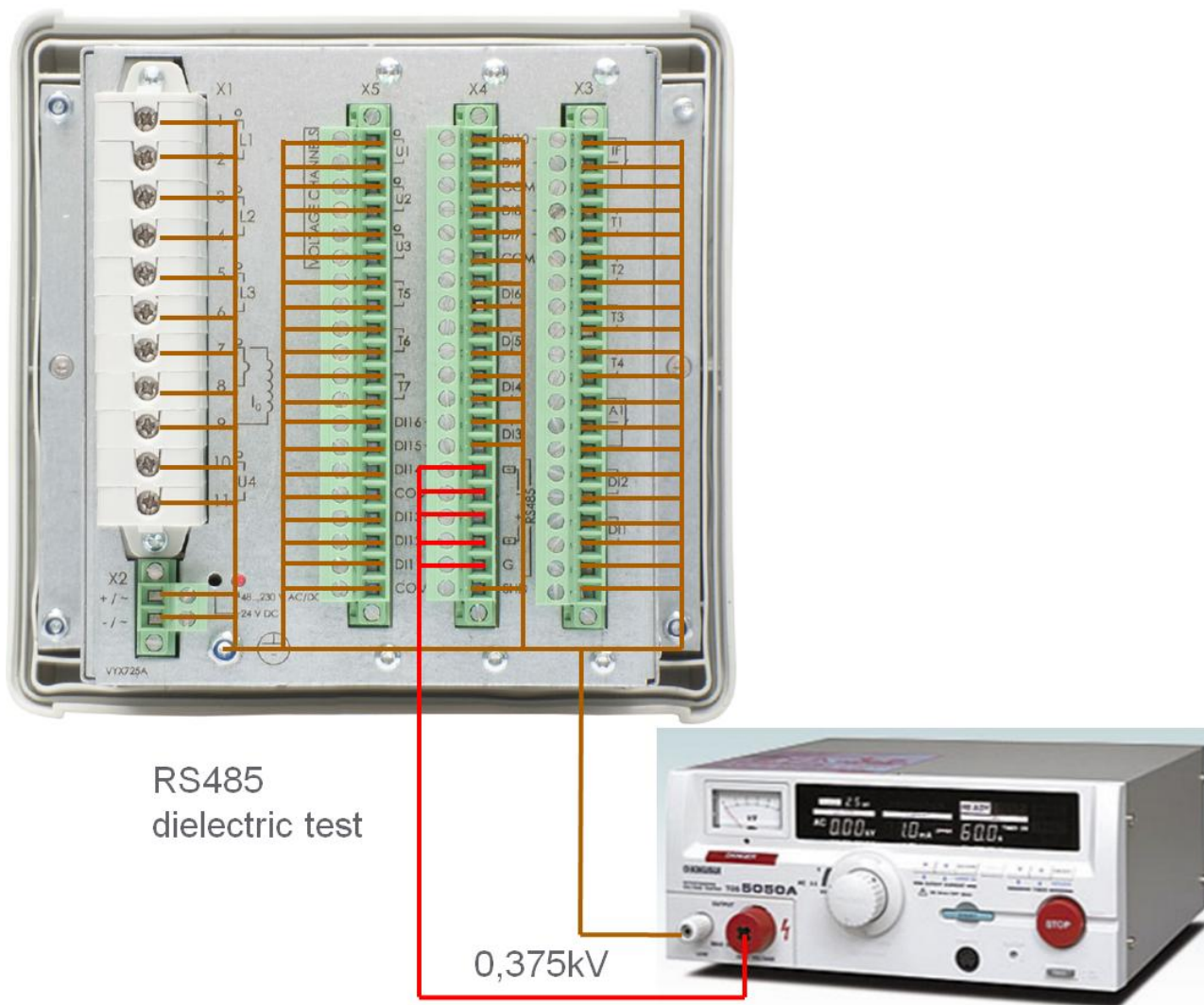

Figure 3. Dielectric test for RS 485 communication port.

## 2.1 Rated voltages for different ports

Table below specifies rated voltages for different ports in different Vamp relay types. Values in table are used in production testing but during installation and commissioning these values must be multiplied by 0.75 as specified in IEC 60255-27 standard.

<b>Dielectric voltage test during commissioning.</b>					
<b>IEC 60255-27 Clause 10.6.4.3.7 Repetition of the dielectric voltage test.</b> For equipment in a new condition, dielectric voltage tests may be repeated, if necessary, to verify their performance. The test voltage value shall be equal to 0,75 times the value claimed by the manufacturer. Manufacturer claimed values are given in table below (test time 1min).					
Port:	IED:				
	V50,V52, V55,V59	V57	V2xx	V257, V259	V300
Uaux (Power supply)	2kV	2kV	2kV	2kV	2kV
Current measurement channels	2kV	2kV	2kV	2kV	2kV
Voltage measurement channels	2kV	2kV	2kV	2kV	2kV
Digital inputs	2kV	2kV	2kV #2	2kV #2	2kV
Relay outputs	2kV	2kV	2kV #2	2kV #2	2kV
mA outputs	0,5kV	n.a.	0,5kV	0,5kV	n.a.
Ethernet	#1	#1	#1	#1	#1
RS485	0,5kV	0,5kV	0,5kV	0,5kV	n.a.
RS232	0,5kV	0,5kV	#1	#1	0,5kV
Other communication ports	#1	#1	#1	#1	#1
Ports for arc protection (Sensor inputs, BI/BO, etc.)	#1	#1	#1	#1	#1
#1 no test allowed during commissioning					
#2 no test allowed for self powered DI channels DI1-DI6					
In generally no dielectric voltage test is recommended for any communication ports during commissioning					

### Schneider Electric

35 rue Joseph Monier  
92506 Rueil-Malmaison  
FRANCE

Phone: +33 (0) 1 41 29 70 00  
Fax: +33 (0) 1 41 29 71 00

[www.schneider-electric/vamp-protection.com](http://www.schneider-electric/vamp-protection.com)

Publishing: 04/2016

© 2016 Schneider Electric Industries SAS - All rights reserved. Electrical equipment should be installed, operated, serviced, and maintained only by qualified personnel. No responsibility is assumed by Schneider Electric for any consequences arising out of the use of this material.