

VAMP 300G

Protection IED

Publication version: V300G/en M/A006

User manual



Trace back information:
Workspace VAMP Range version a4
Checked in 2018-02-13
Skribenta version 5.2.027

Table of Contents

1	General	9
1.1	Legal notice	9
1.2	Safety information	9
1.3	EU directive compliance	11
1.4	Periodical testing	11
1.5	Purpose	12
1.6	Abbreviations	13
2	Introduction	15
2.1	VAMP 300G	15
2.2	Local HMI	16
2.2.1	Push-buttons	17
2.2.2	LEDs	18
2.2.3	Enter password	18
2.2.4	Adjusting LCD contrast (while correct password is enabled)	18
2.2.5	Release all latches (while correct password is enabled)	18
2.2.6	Control object (while password and selective control is enabled)	19
2.2.7	Control object (while password and direct control is enabled)	19
2.2.8	Moving in the menus	19
2.3	VAMPSET setting and configuration tool	21
2.3.1	Folder view	21
2.4	Configuring the system with VAMPSET	22
2.4.1	Setting up the communication	23
2.4.2	Writing the settings to the device	24
2.4.3	Saving the VAMPSET document file	24
3	Mechanical structure	25
3.1	VAMP 300 IED modularity	25
3.2	Slot info and ordering code	27
4	Measurement functions	28
4.1	Measurements for protection functions	28
4.2	Measurements for arc protection function	29
4.3	Measurement accuracy	30
4.4	RMS values	31
4.5	Harmonics and Total Harmonic Distortion (THD)	31
4.6	Demand values	32
4.7	Minimum and maximum values	33
4.8	Maximum values of the last 31 days and 12 months	34

4.9	Voltage measurement modes	35
4.9.1	Multiple channel voltage measurement	35
4.10	Direction of power and current	37
4.11	Symmetric components	38
4.12	Primary secondary and per unit scaling	39
4.12.1	Current scaling	39
4.12.2	Voltage scaling for analogue module C, D, W	42
5	Control functions	45
5.1	Output relays	45
5.2	Digital inputs	48
5.3	Virtual inputs and outputs	52
5.4	Matrix	56
5.4.1	Output matrix	56
5.4.2	Blocking matrix	57
5.4.3	LED matrix	58
5.5	Controllable objects	59
5.5.1	Controlling with DI	61
5.5.2	Local/Remote selection	61
5.5.3	Controlling with I/O	62
5.5.4	Controlling with F1 & F2	62
5.6	Logic functions	63
5.7	Local panel	65
5.7.1	Mimic display	65
5.7.2	Local panel configuration	68
5.7.3	Function buttons	69
6	Protection functions	71
6.1	Maximum number of protection stages in one application	71
6.2	General features of protection stages	72
6.3	Overcurrent protection $I >$ (50/51)	76
6.3.1	Remote controlled overcurrent scaling	81
6.4	Directional phase overcurrent $I_{\phi} >$ (67)	82
6.5	Voltage restrained/controlled phase overcurrent $I_V >$ (51V)	88
6.6	Current unbalance protection $I_2 >$, $I'_2 >$ (46)	91
6.7	Thermal overload protection $T >$ (49)	94
6.8	Earth fault protection $I_0 >$ (50N/51N)	97
6.8.1	Earth fault faulty phase detection algorithm	103
6.9	Directional earth fault protection $I_{0\phi} >$ (67N)	105
6.10	Switch On To Fault (50HS)	112
6.11	Differential overcurrent protection $\Delta I >$ (87)	113
6.12	Overvoltage protection $U >$ (59)	118
6.13	Volts/hertz over-excitation protection $U_f >$ (24)	120
6.14	Synchrocheck (25)	123
6.14.1	Connections for synchrocheck	123
6.15	Undervoltage protection $U <$ (27)	126

6.16	Undervoltage protection $U_{1<}$ (27P)	130
6.17	Zero sequence voltage protection $U_{0>}$ (59N)	133
6.18	100% stator earth fault $U_{0F3<}$ (64F3)	135
6.19	Frequency Protection $f><, f>><<$ (81)	140
6.20	Rate of change of frequency (ROCOF) (81R)	142
6.21	Underimpedance $Z<$ (21)	146
6.22	Under-excitation protection $Q<$ (40)	150
6.23	Under-reactance and loss of excitation protection $X<$ (40)	153
6.24	Reverse power and under-power protection $P<$ (32)	157
6.25	Magnetising inrush $I_{f2} >$ (68F2)	161
6.26	Transformer over excitation $I_{f5} >$ (68F5)	162
6.27	Circuit breaker failure protection CBFP (50BF)	163
6.28	Pole slip protection (78)	164
6.29	Cold load pick-up and magnetising inrush	172
6.30	Programmable stages (99)	174
6.31	Inverse time operation	177
6.31.1	Standard inverse delays IEC, IEEE, IEEE2, RI ...	179
6.31.2	Free parameterization using IEC, IEEE and IEEE2 equations	189
6.31.3	Programmable inverse time curves	190
7	Supporting functions	192
7.1	Event log	192
7.2	Disturbance recorder	194
7.2.1	Running virtual comtrade files	197
7.2.2	Configuring the disturbance recorder	198
7.3	System clock and synchronization	200
7.4	Self-supervision	206
7.4.1	Diagnostics	207
7.5	Voltage sags and swells	209
7.6	Voltage interruptions	210
7.7	Current transformer supervision	213
7.8	Voltage transformer supervision	213
7.9	Circuit breaker condition monitoring	214
7.10	Energy pulse outputs	220
7.11	Running hour counter	223
7.12	Timers	224
7.13	Combined overcurrent status	226
8	Communication and protocols	229
8.1	Communication ports	229
8.1.1	Ethernet port	231
8.2	Communication protocols	234
8.2.1	GetSet	234
8.2.2	Modbus TCP and Modbus RTU	234
8.2.3	Profibus DP	235
8.2.4	SPA-bus	237

8.2.5	IEC 60870-5-103	238
8.2.6	DNP 3.0	240
8.2.7	IEC 60870-5-101	241
8.2.8	External I/O (Modbus RTU master)	241
8.2.9	IEC 61850	242
8.2.10	EtherNet/IP	242
8.2.11	FTP server	243
8.2.12	HTTP server – Webset	243
9	Applications and configuration examples	244
9.1	Trip circuit supervision	244
9.1.1	Trip circuit supervision with one digital input	244
9.1.2	Trip circuit supervision with two digital inputs	250
9.2	Rotor earth-fault protection application	254
10	Connections	255
10.1	I/O cards and optional I/O cards	255
10.2	Supply voltage cards	256
10.3	Analogue measurement cards	257
10.3.1	"C = 3L(5A) + 4U + 2I ₀ (5+1A)"	257
10.3.2	"D = 3L(5A) + 4U + 2I ₀ (1+0.2A)"	258
10.3.3	"W = 3L(1A) + 4U + 2I ₀ (5+1A)"	259
10.3.4	"T = 3 x I (5/1A) + I ₀ (5/1A)"	260
10.3.5	Voltage measuring modes correlation for C, D and W analogue measurement cards	261
10.4	I/O cards	262
10.4.1	I/O card "G = 6DI+4DO"	262
10.4.2	I/O card "I = 10DI"	263
10.5	Communication cards	264
10.5.1	COM 3 – COM 4 ports	267
10.6	Local port (Front panel)	272
10.7	External option modules	273
10.7.1	VSE-001 fiber optic interface module	273
10.7.2	VSE-002 RS-485 interface module	274
10.7.3	VSE-009 DeviceNet interface module	275
10.7.4	VPA-3CG profibus interface module	276
10.7.5	VIO 12A RTD and analog input / output modules	277
10.8	Block diagram	278
10.9	Connection examples	280
11	Technical data	281
11.1	Connections	281
11.2	Test and environmental conditions	287
11.3	Protection functions	289
11.3.1	Differential protection	289
11.3.2	Non-directional current protection	290
11.3.3	Directional current protection	294

11.3.4	Switch On To Fault stage SOTF (50HS)	296
11.3.5	Voltage protection	297
11.3.6	Circuit-breaker failure protection CBFP (50BF) ...	301
11.3.7	Magnetising inrush 68F2	302
11.3.8	Over excitation 68F5	302
11.3.9	Frequency protection	303
11.3.10	Power protection	305
11.3.11	Pole slipping stage (78)	306
11.3.12	Synchrocheck function	307
11.4	Supporting functions	308
12	Mounting	310
13	Order information	313

1 General

1.1 Legal notice

Copyright

2018 Schneider Electric. All rights reserved.

Disclaimer

No responsibility is assumed by Schneider Electric for any consequences arising out of the use of this document. This document is not intended as an instruction manual for untrained persons. This document gives instructions on device installation, commissioning and operation. However, the manual cannot cover all conceivable circumstances or include detailed information on all topics. In the event of questions or specific problems, do not take any action without proper authorization. Contact Schneider Electric and request the necessary information.

Contact information

35 rue Joseph Monier

92500 Rueil-Malmaison

FRANCE

Phone: +33 (0) 1 41 29 70 00

Fax: +33 (0) 1 41 29 71 00

www.schneider-electric.com

1.2 Safety information

Important Information

Read these instructions carefully and look at the equipment to become familiar with the device before trying to install, operate, service or maintain it. The following special messages may appear throughout this bulletin or on the equipment to warn of potential hazards or to call attention to information that clarifies or simplifies a procedure.



The addition of either symbol to a “Danger” or “Warning” safety label indicates that an electrical hazard exists which will result in personal injury if the instructions are not followed.



This is the safety alert symbol. It is used to alert you to potential personal injury hazards. Obey all safety messages that follow this symbol to avoid possible injury or death.

⚠ DANGER

DANGER indicates an imminently hazardous situation which, if not avoided, **will result in** death or serious injury.

⚠ WARNING

WARNING indicates a potentially hazardous situation which, if not avoided, **can result in** death or serious injury.

⚠ CAUTION

CAUTION indicates a potentially hazardous situation which, if not avoided, **can result in** minor or moderate injury.

NOTICE

NOTICE is used to address practices not related to physical injury.

User qualification

Electrical equipment should be installed, operated, serviced, and maintained only by trained and qualified personnel. No responsibility is assumed by Schneider Electric for any consequences arising out of the use of this material. A qualified person is one who has skills and knowledge related to the construction, installation, and operation of electrical equipment and has received safety training to recognize and avoid the hazards involved.

Password protection

Use the IED's password protection feature to protect untrained persons from interacting with this device.

⚠ WARNING**WORKING ON ENERGIZED EQUIPMENT**

Do not choose lower Personal Protection Equipment while working on energized equipment.

Failure to follow these instructions can result in death or serious injury.

1.3 EU directive compliance

EMC compliance

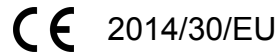

Compliance with the European Commission's EMC Directive. Product Specific Standards were used to establish conformity:

- EN 60255-26: 2013

Product safety

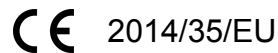

Compliance with the European Commission's Low Voltage Directive. Compliance is demonstrated by reference to generic safety standards:

- EN60255-27:2014

1.4 Periodical testing

The protection IED, cabling and arc sensors must periodically be tested according to the end-user's safety instructions, national safety instructions or law. The manufacturer recommends that functional testing is carried out at the minimum every five (5) years.

It is proposed that the periodic testing is conducted with a secondary injection principle for those protection stages which are used in the IED and its related units.

1.5 Purpose

This document contains instructions on the installation, commissioning and operation of VAMP 300G.

This document is intended for persons who are experts on electrical power engineering, and it covers the device models as described by the ordering code in Chapter 13 Order information.

Related documents

Document	Identification ^{*)}
VAMP 300 Series Local HMI Alarm List	AN300.ENxxxx
VAMP Relay Mounting and Commissioning Instructions	VRELAY_MC_xxxx
VAMPSET Setting and Configuration Tool User Manual	VVAMPSET_EN_M_xxxx

^{*)} *xxxx = revision number*

Download the latest software and manual at
www.schneider-electric.com/vamp-protection or m.vamp.fi.

1.6 Abbreviations

ANSI	American National Standards Institute. A standardization organisation.
CB	Circuit breaker
CBFP	Circuit breaker failure protection
$\cos\phi$	Active power divided by apparent power = P/S. (See power factor PF). Negative sign indicates reverse power.
CT	Current transformer
CT_{PRI}	Nominal primary value of current transformer
CT_{SEC}	Nominal secondary value of current transformer
Dead band	See hysteresis.
DI	Digital input
DO	Digital output, output relay
Document file	Stores information about the IED settings, events and fault logs.
DSR	Data set ready. An RS232 signal. Input in front panel port of VAMP relays to disable rear panel local port.
DST	Daylight saving time. Adjusting the official local time forward by one hour for summer time.
DTR	Data terminal ready. An RS232 signal. Output and always true (+8 Vdc) in front panel port of VAMP relays.
FFT	Fast Fourier transform. Algorithm to convert time domain signals to frequency domain or to phasors.
FPGA	Field-programmable gate array
HMI	Human-machine interface
Hysteresis	I.e. dead band. Used to avoid oscillation when comparing two near by values.
I_{MODE}	Nominal current of the selected mode. In feeder mode, $I_{MODE} = VT_{PRIMARY}$. In motor mode, $I_{MODE} = I_{MOT}$.
I_{MOT}	Nominal current of the protected motor
I_N	Nominal current. Rating of CT primary or secondary.
I_{SET}	Another name for pick up setting value I>
I_{ON}	Nominal current of I_0 input in general
IEC	International Electrotechnical Commission. An international standardization organisation.
IEC-101	Abbreviation for communication protocol defined in standard IEC 60870-5-101
IEC-103	Abbreviation for communication protocol defined in standard IEC 60870-5-103
IED	Intelligent electronic device, refers to VAMP 300G in this document
IEEE	Institute of Electrical and Electronics Engineers
LAN	Local area network. Ethernet based network for computers and IEDs.
Latching	Output relays and indication LEDs can be latched, which means that they are not released when the control signal is releasing. Releasing of latched devices is done with a separate action.
LCD	Liquid crystal display
LED	Light-emitting diode
Local HMI	IED front panel with display and push-buttons
NTP	Network Time Protocol for LAN and WWW
P	Active power. Unit = [W]
PF	Power factor. The absolute value is equal to $\cos\phi$, but the sign is '+' for inductive i.e. lagging current and '-' for capacitive i.e. leading current.
P_M	Nominal power of the prime mover. (Used by reverse/under power protection.)

PT	See VT
pu	Per unit. Depending of the context the per unit refers to any nominal value. For example for overcurrent setting $1 \text{ pu} = 1 \times I_{\text{MODE}}$.
Q	Reactive power. Unit = [var] acc. IEC
RMS	Root mean square
S	Apparent power. Unit = [VA]
SF	IED status inoperative
SNTP	Simple Network Time Protocol for LAN and WWW
SPST	Single pole single throw
SPDT	Single pole double throw
TCS	Trip circuit supervision
THD	Total harmonic distortion
$U_{0\text{SEC}}$	Voltage at input U_c at zero ohm ground fault. (Used in voltage measurement mode "2LL+ U_0 ")
U_A	Voltage input for U_{12} or U_{L1} depending of the voltage measurement mode
U_B	Voltage input for U_{23} or U_{L2} depending of the voltage measurement mode
U_C	Voltage input for U_{31} or U_0 depending of the voltage measurement mode
U_N	Nominal voltage. Rating of VT primary or secondary
UTC	Coordinated Universal Time (used to be called GMT = Greenwich Mean Time)
VAMPSET	Configuration tool for VAMP protection devices
VAMP 300 IED	Refers VAMP 300 series platform in general
VAMP 300G	Refers VAMP 300 series generator protection IED
Webset	http configuration interface
VT	Voltage transformer i.e. potential transformer PT
VT_{PRI}	Nominal primary value of voltage transformer
VT_{SEC}	Nominal secondary value of voltage transformer

2 Introduction

2.1 VAMP 300G

VAMP 300G has a modular design, and it can be optimized to medium and big sized generators.

Main characteristic and options

- VAMP 300G is a generator-block transformer protection relay for medium sized generators in power generation. Synchrocheck and auto-reclosing extend automatic network control
- Two alternative display options
 - 128 x 128 LCD matrix
 - 128 x 128 LCD matrix detachable
- Power quality measurements and disturbance recorder enable capture of quick network phenomena
- Wide range of communication protocols i.e. IEC61850, Profibus DP to Modbus TCP

Following options depend on the ordering code

- Multiple power supply options
- residual current inputs
- amount of digital inputs
- amount of trip contacts
- various possibilities with communication interfaces

VAMP 300G IED has good protection against harsh environments. Protective level is IP54.

2.2 Local HMI

VAMP 300G has 128 x 128 LCD matrix display.

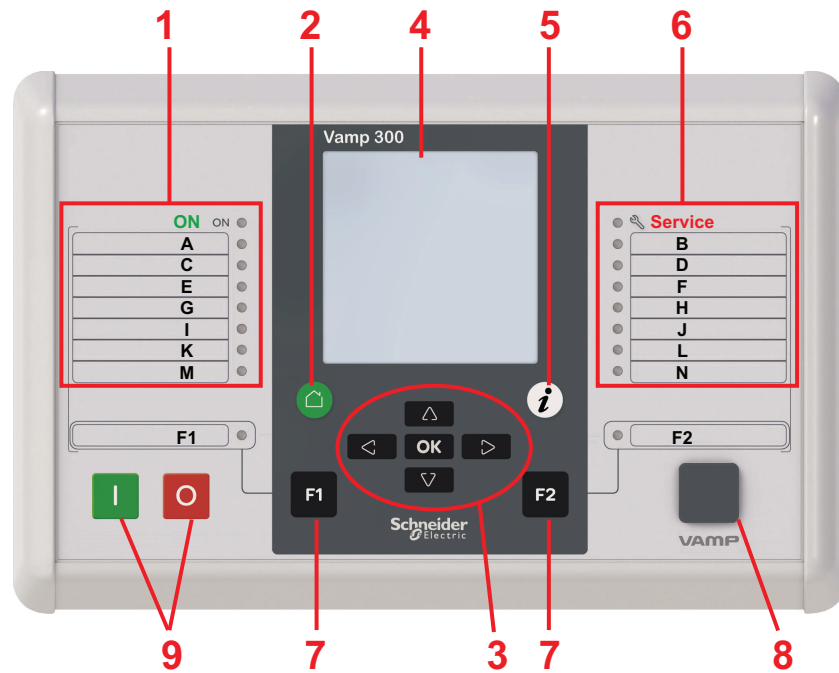













Figure 2.1: VAMP 300G local HMI

- | | |
|---|---|
| 1 | Power LED and seven programmable LEDs |
| 2 | CANCEL push-button |
| 3 | Navigation push-buttons |
| 4 | LCD |
| 5 | INFO push-button |
| 6 | Status LED and seven programmable LEDs |
| 7 | Function push-buttons and LEDs showing their status |
| 8 | Local port |
| 9 | Object control buttons |

2.2.1 Push-buttons

Symbol	Function
	CANCEL push-button for returning to the previous menu. To return to the first menu item in the main menu, press the button for at least three seconds.
	INFO push-button for viewing additional information, for entering the password view and for adjusting the LCD contrast.
	Programmable function push-button.
	Programmable function push-button.
	ENTER push-button for activating or confirming a function.
	UP navigation push-button for moving up in the menu or increasing a numerical value.
	DOWN navigation push-button for moving down in the menu or decreasing a numerical value.
	LEFT navigation push-button for moving backwards in a parallel menu or selecting a digit in a numerical value.
	RIGHT navigation push-button for moving forwards in a parallel menu or selecting a digit in a numerical value.
	Circuit Breaker ON push-button
	Circuit Breaker OFF push-button

Configuring the LED names

1. On the VAMPSET group list, select **LED NAMES**.
2. To change a LED name, click the LED **Description** text and type a new name. Press **Enter**.

LED	Description	LED	Description
LED A (green)	LED A (green)	LED B (green)	LED B (green)
LED A (red)	LED A (red)	LED B (red)	LED B (red)
LED C (green)	LED C (green)	LED D (green)	LED D (green)
LED C (red)	LED C (red)	LED D (red)	LED D (red)
LED E (green)	LED E (green)	LED F (green)	LED F (green)
LED E (red)	LED E (red)	LED F (red)	LED F (red)
LED G (green)	LED G (green)	LED H (green)	LED H (green)
LED G (red)	LED G (red)	LED H (red)	LED H (red)
LED I (green)	LED I (green)	LED J (green)	LED J (green)
LED I (red)	LED I (red)	LED J (red)	LED J (red)
LED K (green)	LED K (green)	LED L (green)	LED L (green)
LED K (red)	LED K (red)	LED L (red)	LED L (red)
LED M (green)	LED M (green)	LED N (green)	LED N (green)
LED M (red)	LED M (red)	LED N (red)	LED N (red)



Figure 2.2: LED NAMES menu in VAMPSET for LED configuration

2.2.2 LEDs





VAMP 300G has 18 LEDs on front. Two LEDs represents units general status (On & ) , two LEDs for function buttons (F1 & F2) and 14 user configurable LEDs (A - N). When the device is powered the “ON” LED will lit as green. During normal use “Service” LED is not active, it activates only when error occurs or the device is not operating correctly. Should this happen contact your local representative for further guidance.

can lit either green or red. The LEDs on the local HMI can be configured in VAMPSET. To customise the LED texts on the local HMI, the texts can be written on a template and then printed on a transparency. The transparencies can be placed to the pockets beside the LEDs.



2.2.3 Enter password

1. On the local HMI, press  and .
2. Enter the four-digit password and press .

2.2.4 Adjusting LCD contrast (while correct password is enabled)

1. Press  and adjust the contrast.
 - To increase the contrast, press .
 - To decrease the contrast, press .
2. To return to the main menu, press .

2.2.5 Release all latches (while correct password is enabled)

1. Press 
 - To release the latches, press .
 - To release, choose “Release” parameter and press .

2.2.6 Control object (while password and selective control is enabled)

When selective control is enabled, control operation needs confirmation (select-execute)

1. Press **I** to close object.
 - Press **I** again to confirm.
 - Press **⏠** to cancel.
2. Press **O** to open object.
 - Press **O** again to confirm.
 - Press **⏠** to cancel.

2.2.7 Control object (while password and direct control is enabled)

When direct control is enabled, control operation is done without confirmation

1. Press **I** to close object.
2. Press **O** to open object.

2.2.8 Moving in the menus

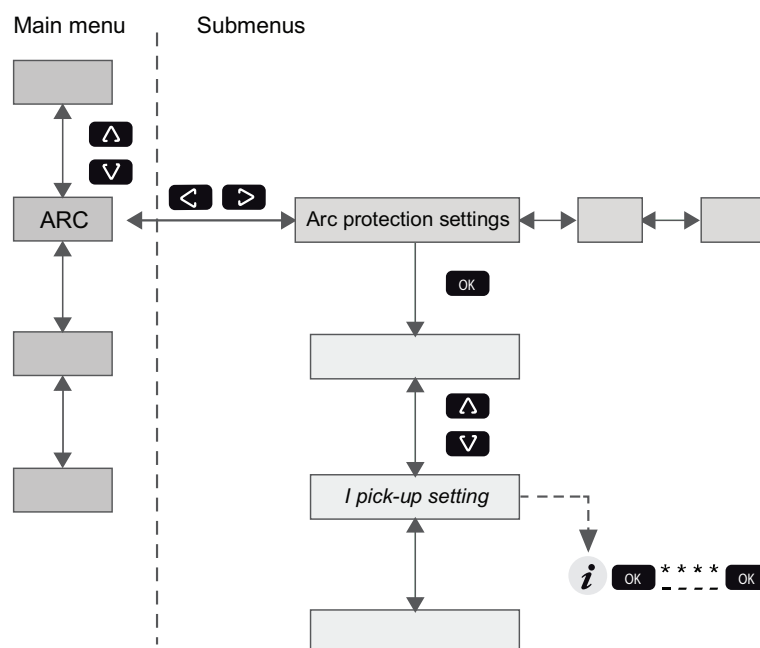













Figure 2.3: Moving in menus using local HMI

- To move in the main menu, press  or .
- To move in submenus, press  or .
- To enter a submenu, press  and use  or  for moving down or up in the menu.
- To edit a parameter value, press  and . Key in four-digit password and press .
- To go back to the previous menu, press .
- To go back to the first menu item in the main menu, press  for at least three seconds.

NOTE: To enter the parameter edit mode, key in the password. When the value is in edit mode, its background is dark.

2.3 VAMPSET setting and configuration tool

⚠ DANGER

HAZARD OF ELECTRIC SHOCK, EXPLOSION, OR ARC FLASH

Only qualified personnel should operate this equipment. Such work should be performed only after reading this entire set of instructions and checking the technical characteristics of the device.

Failure to follow this instruction will result in death or serious injury.

VAMPSET is a software tool for setting and configuring the VAMP devices. VAMPSET has a graphical interface, and the created documents can be saved and printed out for later use.

To use VAMPSET, you need

- PC with Windows XP (or newer) operating system installed
- VX052 or equivalent USB cable for connecting the device to the PC (VX052 USB cable is recommended)
- Experience in using the Windows operating system

NOTE: Download the latest VAMPSET version at www.schneider-electric.com/vamp-protection or m.vamp.fi.

2.3.1 Folder view

In VAMPSET version 2.2.136, a feature called "Folder view" was introduced.

The idea of folder view is to make it easier for the user to work with relay functions inside VAMPSET. When folder view is enabled, VAMPSET gathers similar functions together and places them appropriately under seven different folders (GENERAL, MEASUREMENTS, INPUTS/OUTPUTS, MATRIX, LOGS and COMMUNICATION). The contents (functions) of the folders depend on the relay type and currently selected application mode.

Folder view can be enabled in VAMPSET via Program Settings dialog (Settings -> Program Settings), see Figure 2.4.

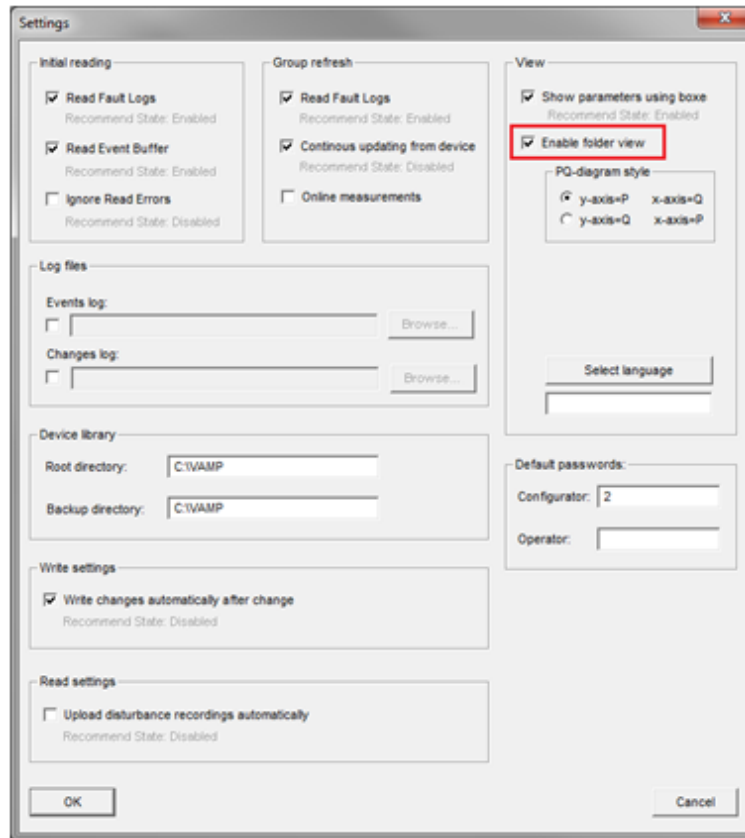

Figure 2.4: Enable folder view setting in Program Settings dialog

NOTE: It is possible to enable/ disable the folder view only when VAMPSET is disconnected from the relay and there is no configuration file opened.

When folder view is enabled, folder buttons become visible in VAMPSET, see Figure 2.5. Currently selected folder appears in bold.



Figure 2.5: Folder view buttons

2.4 Configuring the system with VAMPSET

NOTICE

RISK OF SYSTEM SHUTDOWN

After writing new settings or configurations to a relay, perform a test to verify that the relay operates correctly with the new settings.

Failure to follow these instructions can result in unwanted shutdown of the electrical installation.

Before configuring the protection relay, you need

- PC with adequate user rights
- VAMPSET setting and configuration tool downloaded to the PC
- USB cable (VX052) for connecting the device with the PC

2.4.1 Setting up the communication

- Connect the USB cable between the PC and the local port of the device.

Defining the PC serial port settings

NOTE: Ensure that the communication port setting on the PC corresponds to the device setting.

1. Open the **Device Manager** on the PC and check the USB Serial Port number (COM) for the device.
2. Open the VAMPSET setting and configuration tool on the PC.
3. On the VAMPSET **Settings** menu, select **Communication Settings**.
4. Select the correct port under the **Port** area and click **Apply**.

Defining the VAMPSET communication settings

1. On the local HMI, go to the **CONF/ DEVICE SETUP** menu and check the local port bit rate.
2. On the VAMPSET **Settings** menu, select **Communication Settings**.
3. Under the **Local** area, select the corresponding speed (bps) from the drop-down list and click **Apply**.
4. In VAMPSET **Settings** menu, select **Program Settings**.

NOTE: If faster operation is needed, change the speed to 187500 bps both in VAMPSET and in the device.

Connecting the device

1. On the VAMPSET **Communication** menu, select **Connect Device**.
2. Enter the password and click **Apply**. VAMPSET connects to the device.

NOTE: The default password for the configurator is 2.

2.4.2 Writing the settings to the device

- In the VAMPSET **Communication** menu, select **Write All Settings To Device** to download the configuration to the device.

NOTE: To save the device configuration information for later use, also save the VAMPSET document file on the PC.

2.4.3 Saving the VAMPSET document file

Save the device configuration information to the PC. The document file is helpful for instance if you need help in troubleshooting.

1. Connect the device to the PC with an USB cable.
2. Open the VAMPSET tool on the PC.
3. On the **Communication** menu, select **Connect device**.
4. Enter the configurator password. The device configuration opens.
5. On the **File** menu, click **Save as**.
6. Type a descriptive file name, select the location for the file and click **Save**.

NOTE: By default, the configuration file is saved in the VAMPSET folder.

3 Mechanical structure

3.1 VAMP 300 IED modularity

The device has a modular structure. The device is built from hardware modules, which are installed into 10 different slots at the back of the device. The location of the slots is shown in the following figure.

The type of hardware modules is defined by the ordering code. A minimum configuration is that there is a supply voltage card in slot 1 and an analogue measurement card in slot 8.

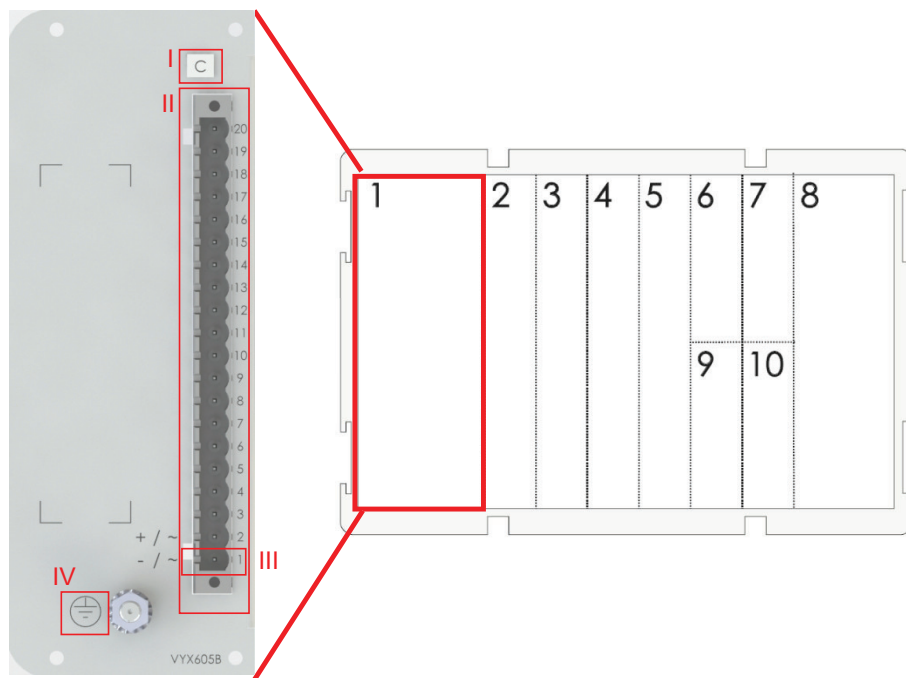

I	Card C	1	Supply voltage [V]
II	Connector 2	2	I/O card I
		4 – 5	Optional analog measurement card I
		6, 7	I/O option cards I and II
		8	Analog measurement card (I, U)
		9, 10	Communication interface I and II

Figure 3.1: Slot numbering and card options in the VAMP 300 rear panel and an example of defining the pin address 1/C/2:1

NOTE: Slots 7 and 10 are not available.

For complete availability of different option cards please refer Chapter 13 Order information.

Chapter 10 Connections has detailed information of each card.

Table 3.1: Example - V300G-CGITA-AACNA-B2

SLOT	NAME	TYPE
	Application	G = Generator
1	Supply voltage	Power C 110 – 230 V (80 – 265Vac/dc, 5 x DO heavy duty, A1, SF)
2	I/O card I	G = 6DI+4DO (6 x DI, 4 x DO)
3	I/O card II	I = 10DI (10 x DI)
4	I/O card III	T = 3xI (5/1A) + Io (5/1A) for Transformer differential, excludes I/O card in slot 5
5	I/O card IV	A = None
6	Option card I	A = None
7	Future option	A = None
8	Analog measurement card (See application)	C = 3L(5A)+4U+2Io (5+1A)
9	Communication interface I	N = 2xRJ (Ethernet RJ 100 Mbs, RSTP)
10	Future option	A = None
	Display type	B = 128x128 (128 x 128 LCD matrix)
	DI nominal voltage	2 = 110 Vdc/ac

3.2 Slot info and ordering code

The configuration of the device can be checked from local HMI or VAMPSET menu called “Slot” or “SLOT INFO”. This contains “Card ID” which is the name of the card used by the device firmware.

SLOT INFO

Slot	Card ID	Trace ID	Status
1	Pwr 80-265		OK
2	3xS+F+BI+BO		OK
3	6xDI+4xDO		OK
4	10xDO		OK
5	None	-	-
6	4xDO		OK
7	None	-	-
8	3L+lo5/1+4U		OK
9	RS232+RJ45		OK
10	None	-	-
Display	128x64		OK

Figure 3.2: Hardware configuration example view from VAMPSET configuration tool.

NOTE: See Chapter 13 Order information to order a certain type of IED.

An example: User wants to have a generator protection IED with 9 trip contacts, 12 digital inputs, and Ethernet communication. Following order code fulfils the requirements:

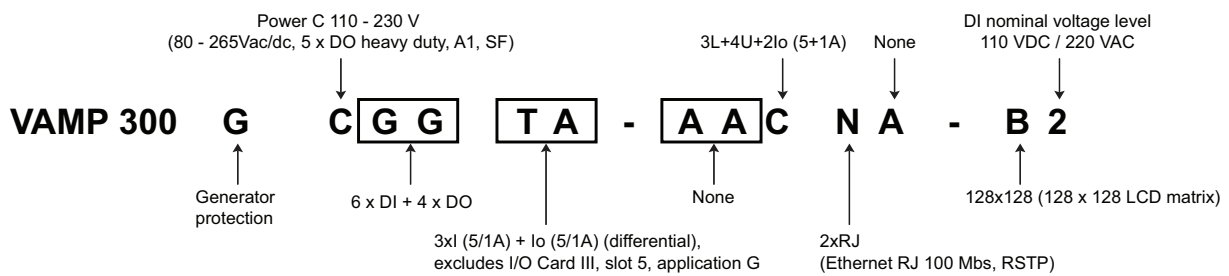

4 Measurement functions

4.1 Measurements for protection functions

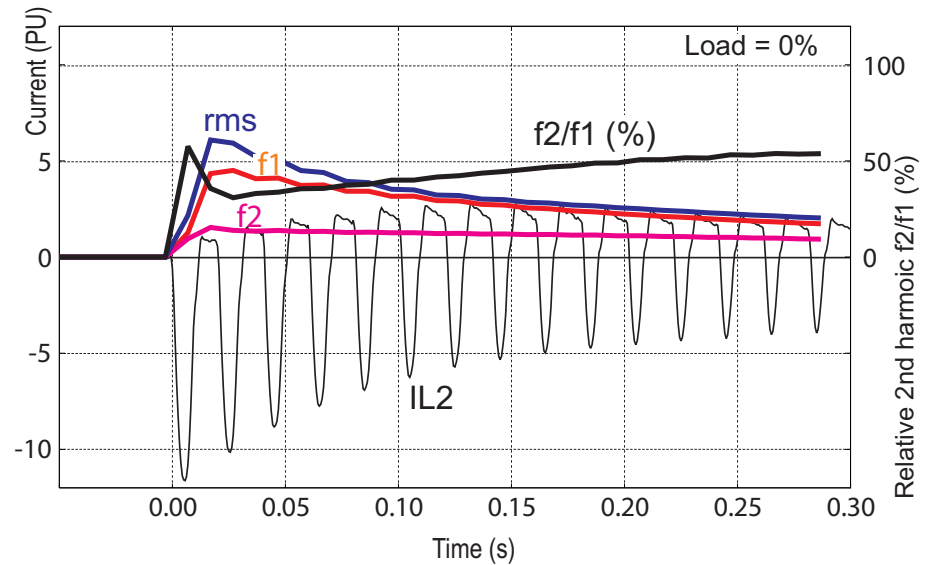

Figure 4.1: Example of various current values of a transformer inrush current

All the direct measurements are based on fundamental frequency values. The exceptions are frequency and instantaneous current for arc protection. Most protection functions are also based on the fundamental frequency values.

Figure 4.1 shows a current waveform and the corresponding fundamental frequency component f_1 , second harmonic f_2 , and rms value in a special case, when the current deviates significantly from a pure sine wave.

4.2 Measurements for arc protection function

The three phase current measurement and ground fault current measurement for arc protection is done with electronics (see Figure 4.2). The electronics compares the current levels to the pick-up settings - THRESHOLDS - and gives a binary signals "I>" or "I₀₁>" to the arc protection function if limit is exceeded. All the frequency components of the currents are taken into account.

Signals "I>" or "I₀₁>" are connected to a FPGA chip which implements the arc protection function. The pick-up settings are named "I> int" and "I₀₁> int" in the local LCD panel or VAMPSET views, these settings are used to set the THRESHOLD levels for the electronics.

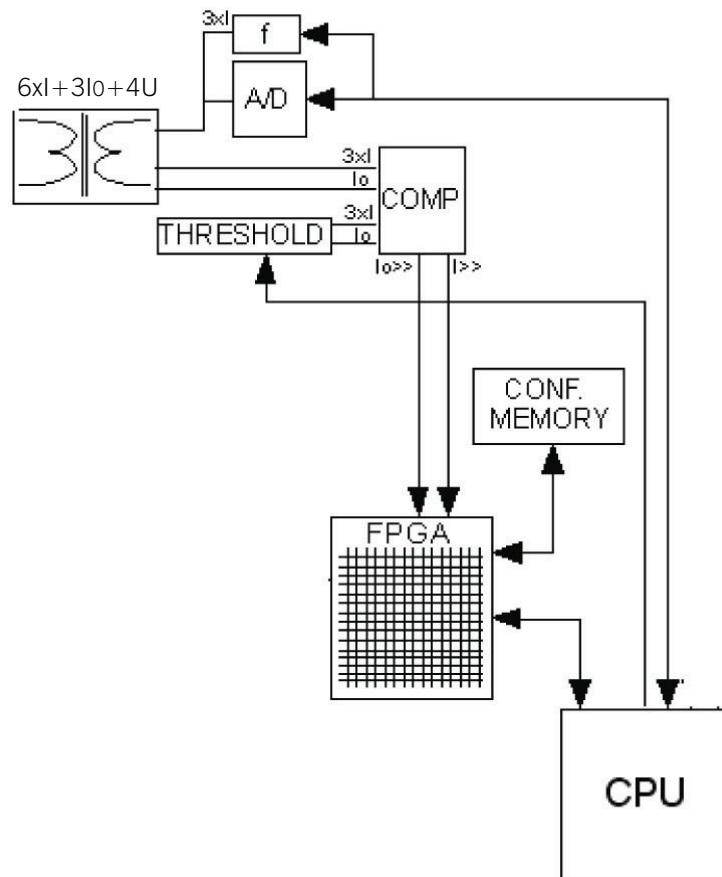

Figure 4.2: Measurement logic for the arc flash protection function

4.3 Measurement accuracy

Table 4.1: Phase current inputs I_{L1} , I_{L2} , I_{L3}

Measuring range	0.05 – 250 A
Inaccuracy:	
$I \leq 7.5$ A	± 0.5 % of value or ± 15 mA
$I > 7.5$ A	± 3 % of value
The specified frequency range is 45 Hz – 65 Hz.	

Table 4.2: Voltage inputs U

Measuring range	0.5 – 190 V
Inaccuracy	± 0.5 % or ± 0.3 V
The specified frequency range is 45 Hz – 65 Hz.	

Table 4.3: Residual current input I_{0N}

Measuring range	0.003 – $10 \times I_{0N}$
Inaccuracy:	
$I \leq 1.5 \times I_N$	± 0.3 % of value or ± 0.2 % of I_{0N}
$I > 1.5 \times I_N$	± 3 % of value
The rated input I_{0N} is 5A, 1 A or 0.2 A. It is specified in the order code of the relay.	
The specified frequency range is 45 Hz – 65 Hz.	

Table 4.4: Frequency

Measuring range	16 Hz – 75 Hz
Inaccuracy	± 10 mHz
The frequency is measured from voltage signals when least four voltages are measured. With only one voltage (F&I) the frequency is measured from currents.	

Table 4.5: THD and harmonics

Inaccuracy I , $U > 0.1$ PU	± 2 % units
Update rate	Once a second
The specified frequency range is 45 Hz – 65 Hz.	

NOTE: These measurement accuracies are only valid for the user interface and communication.

4.4 RMS values

RMS currents

The device calculates the RMS value of each phase current. The minimum and the maximum of RMS values are recorded and stored (see Chapter 4.7 Minimum and maximum values).

$$I_{RMS} = \sqrt{I_{f1}^2 + I_{f2}^2 + \dots + I_{f15}^2}$$

RMS voltages

The device calculates the RMS value of each voltage input. The minimum and the maximum of RMS values are recorded and stored (see Chapter 4.7 Minimum and maximum values).

$$U_{RMS} = \sqrt{U_{f1}^2 + U_{f2}^2 + \dots + U_{f15}^2}$$

4.5 Harmonics and Total Harmonic Distortion (THD)

The device calculates the THDs as a percentage of the currents and voltages values measured at the fundamental frequency. The device calculates the harmonics from the 2nd to the 15th of phase currents and voltages. (The 17th harmonic component will also be shown partly in the value of the 15th harmonic component. This is due to the nature of digital sampling.)

The harmonic distortion is calculated

$$THD = \frac{\sqrt{\sum_{i=2}^{15} f_i^2}}{h_1}$$

$h_1 =$ Fundamental value
 $h_{2-15} =$ Harmonics

Example

$$h_1 = 100 \text{ A}, \quad h_3 = 10 \text{ A}, \quad h_7 = 3 \text{ A}, \quad h_{11} = 8 \text{ A}$$

$$THD = \frac{\sqrt{10^2 + 3^2 + 8^2}}{100} = 13.2\%$$

For reference the RMS value is

$$RMS = \sqrt{100^2 + 10^2 + 3^2 + 8^2} = 100.9 \text{ A}$$

Another way to calculate THD is to use the RMS value as reference instead of the fundamental frequency value. In the example above the result would then be 13.0 %.

4.6 Demand values

The relay calculates average i.e. demand values of phase currents I_{L1} , I_{L2} , I_{L3} and power values S, P and Q.

The demand time is configurable from 10 minutes to 60 minutes with parameter "Demand time".

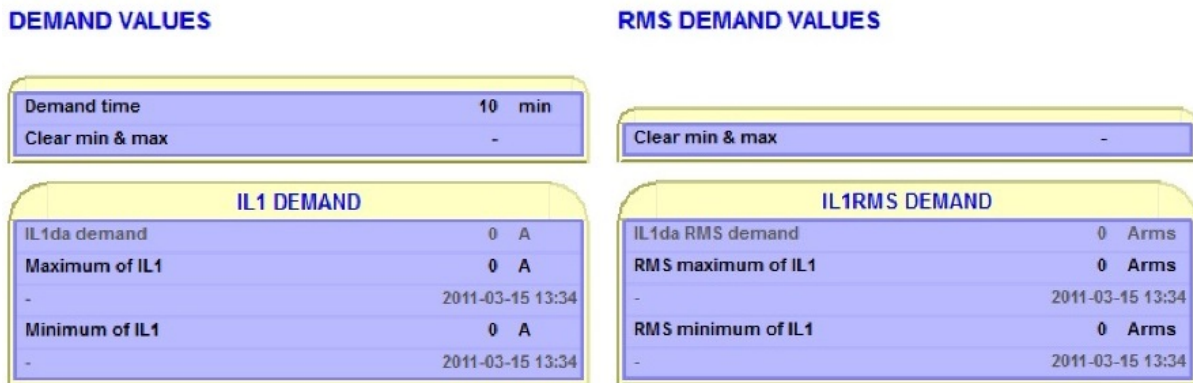

Figure 4.3: Demand values

Table 4.6: Demand value parameters

Parameter	Value	Unit	Description	Set
Time	10 – 30	min	Demand time (averaging time)	Set
Fundamental frequency values				
IL1da		A	Demand of phase current IL1	
IL2da		A	Demand of phase current IL2	
IL3da		A	Demand of phase current IL3	
Pda		kW	Demand of active power P	
PFda			Demand of power factor PF	
Qda		Kvar	Demand of reactive power Q	
Sda		kVA	Demand of apparent power S	
RMS values				
IL1RMSda		A	Demand of RMS phase current IL1	
IL2RMSda		A	Demand of RMS phase current IL2	
IL3RMSda		A	Demand of RMS phase current IL3	
Prmsda		kW	Demand of RMS active power P	
Qrmsda		kvar	Demand of RMS reactive power Q	
Srmsda		kVA	Demand of RMS apparent power S	

Set = An editable parameter (password needed).

4.7 Minimum and maximum values

Minimum and maximum values are registered with time stamps since the latest manual clearing or since the device has been restarted. The available registered min & max values are listed in the following table.

CURRENT MINIMUMS and MAXIMUMS	VOLTAGE MINIMUMS and MAXIMUMS	POWER MINIMUMS and MAXIMUMS																																																						
<div style="border: 1px solid black; padding: 2px; margin-bottom: 5px;">Clear min & max -</div> <div style="border: 1px solid black; padding: 5px;"> <p style="text-align: center; margin: 0;">IL1 MIN/MAX</p> <table style="width: 100%; border-collapse: collapse;"> <tr> <td style="width: 60%;">Minimum of IL1</td> <td style="width: 20%; text-align: right;">0 A</td> <td style="width: 20%;"></td> </tr> <tr> <td>-</td> <td style="text-align: right;">2011-03-15</td> <td></td> </tr> <tr> <td>-</td> <td style="text-align: right;">13:34:26</td> <td></td> </tr> <tr> <td>Maximum of IL1</td> <td style="text-align: right;">0 A</td> <td></td> </tr> <tr> <td>-</td> <td style="text-align: right;">2011-03-15</td> <td></td> </tr> <tr> <td>-</td> <td style="text-align: right;">13:34:26</td> <td></td> </tr> </table> </div>	Minimum of IL1	0 A		-	2011-03-15		-	13:34:26		Maximum of IL1	0 A		-	2011-03-15		-	13:34:26		<div style="border: 1px solid black; padding: 5px;"> <p style="text-align: center; margin: 0;">U_A MIN/MAX</p> <table style="width: 100%; border-collapse: collapse;"> <tr> <td style="width: 60%;">Minimum of U_A</td> <td style="width: 20%; text-align: right;">0 V</td> <td style="width: 20%;"></td> </tr> <tr> <td>-</td> <td style="text-align: right;">2011-03-15</td> <td></td> </tr> <tr> <td>-</td> <td style="text-align: right;">13:34:26</td> <td></td> </tr> <tr> <td>Maximum of U_A</td> <td style="text-align: right;">0 V</td> <td></td> </tr> <tr> <td>-</td> <td style="text-align: right;">2011-03-15</td> <td></td> </tr> <tr> <td>-</td> <td style="text-align: right;">13:34:26</td> <td></td> </tr> </table> </div>	Minimum of U _A	0 V		-	2011-03-15		-	13:34:26		Maximum of U _A	0 V		-	2011-03-15		-	13:34:26		<div style="border: 1px solid black; padding: 5px;"> <p style="text-align: center; margin: 0;">FREQ. MIN/MAX</p> <table style="width: 100%; border-collapse: collapse;"> <tr> <td style="width: 60%;">Minimum frequency</td> <td style="width: 20%; text-align: right;">0.000 Hz</td> <td style="width: 20%;"></td> </tr> <tr> <td>-</td> <td style="text-align: right;">2011-03-15</td> <td></td> </tr> <tr> <td>-</td> <td style="text-align: right;">13:34:26</td> <td></td> </tr> <tr> <td>Maximum frequency</td> <td style="text-align: right;">0.000 Hz</td> <td></td> </tr> <tr> <td>-</td> <td style="text-align: right;">2011-03-15</td> <td></td> </tr> <tr> <td>-</td> <td style="text-align: right;">13:34:26</td> <td></td> </tr> </table> </div>	Minimum frequency	0.000 Hz		-	2011-03-15		-	13:34:26		Maximum frequency	0.000 Hz		-	2011-03-15		-	13:34:26	
Minimum of IL1	0 A																																																							
-	2011-03-15																																																							
-	13:34:26																																																							
Maximum of IL1	0 A																																																							
-	2011-03-15																																																							
-	13:34:26																																																							
Minimum of U _A	0 V																																																							
-	2011-03-15																																																							
-	13:34:26																																																							
Maximum of U _A	0 V																																																							
-	2011-03-15																																																							
-	13:34:26																																																							
Minimum frequency	0.000 Hz																																																							
-	2011-03-15																																																							
-	13:34:26																																																							
Maximum frequency	0.000 Hz																																																							
-	2011-03-15																																																							
-	13:34:26																																																							

Figure 4.4: Minimum and maximum values

Min & Max measurement	Description
IL1, IL2, IL3	Phase current (fundamental frequency value)
IL1RMS, IL2RMS, IL3RMS	Phase current, rms value
I_{01} , I_{02}	Residual current
U _A , U _B , U _C , U _D	Voltages, fundamental frequency values
U _A RMS, U _B RMS, U _C RMS, U _D RMS	Line-to-neutral voltages, RMS value
U ₀	Zero sequence voltage
f	Frequency
P, Q, S	Active, reactive, apparent power
IL1da, IL2da, IL3da	Demand values of phase currents
IL1da, IL2da, IL3da (rms value)	Demand values of phase currents, rms values
P.F.	Power factor

The clearing parameter "ClrMax" is common for all these values.

Table 4.7: Parameters

Parameter	Value	Description	Set
ClrMax	-	Reset all minimum and maximum values	Set
	Clear		

Set = An editable parameter (password needed).

4.8 Maximum values of the last 31 days and 12 months

Maximum and minimum values of the last 31 days and the last twelve months are stored in the non-volatile memory of the relay. Corresponding time stamps are stored for the last 31 days. The registered values are listed in the following table.

MONTH MAX

Timebase for maximums	1s
Reset 31 days max	-
Reset month max	-

PAST 31 DAYS			
Description	Measurement	Date	Time of day
IL1max	2504 A	2011-03-11	09:49:48

PAST 12 MONTHS											
Month	Year	IL1max	IL2max	IL3max	Iomax	Io2max	Pmax	Pmin	Qmax	Qmin	Smax
JANUARY	2011	0 A	0 A	0 A	0.00 A	0.00 A	0 kW	0 kW	0 kvar	0 kvar	0 kVA

Figure 4.5: Past 31 days and 12 month maximums/minimums can be viewed in “month max” menu.

Measurement	Max	Min	Description	31 days	12 months
IL1, IL2, IL3	X		Phase current (fundamental frequency value)		
Io1, Io2	X		Residual current		
S	X		Apparent power	X	X
P	X	X	Active power	X	X
Q	X	X	Reactive power	X	X

Timebase can be a value from one cycle to one minute. Also demand value can be used as timebase and its value can be set between 10 - 60 minutes. Demand value menu is located under the “logs” leaflet -> demand values.

Table 4.8: Parameters of the day and month registers

Parameter	Value	Description	Set
Timebase		Parameter to select the type of the registered values	Set
	20 ms	Collect min & max of one cycle values *	
	200 ms	Collect min & max of 200 ms average values	
	1 s	Collect min & max of 1 s average values	
	1 min	Collect min & max of 1 minute average values	
	demand	Collect min & max of demand values (Chapter 4.6 Demand values)	
ResetDays		Reset the 31 day registers	Set
ResetMon		Reset the 12 month registers	Set

Set = An editable parameter (password needed).

* This is the fundamental frequency rms value of one cycle updated every 20 ms.

4.9 Voltage measurement modes

Depending on the application and available voltage transformers, the relay can be connected either to zero-sequence voltage, one line-to-line voltage or one phase-to-ground voltage. The configuration parameter "Voltage measurement mode" must be set according to the type of connection used.

4.9.1 Multiple channel voltage measurement

The slot 8 can accommodate four different analogue measurement cards.

Model A has only one voltage input where as models B, C and D have four voltage measurement channels.

- C = 3L+4U+2Io (5+1 A)
- D = 3L+4U+2Io (1+0.2 A)
- W = 3L(1A)+4U+2Io (5+1A)

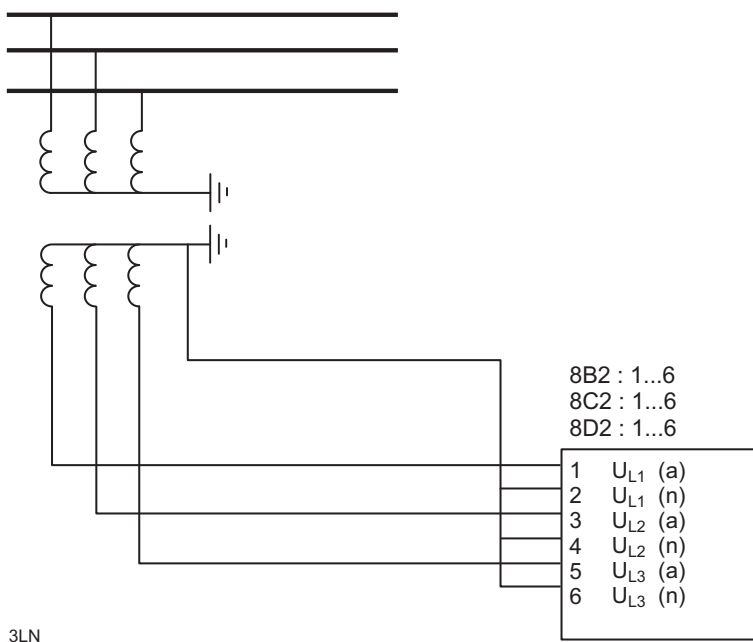

Voltage measuring mode: **3LN**

- Voltages measured by VTs: UL1, UL2, UL3
- Values calculated: UL12, UL23, UL31, U1, U2, U2/U1, f, U₀
- Measurements available: All
- Protection functions available: All except intermittent e/f and synchrocheck

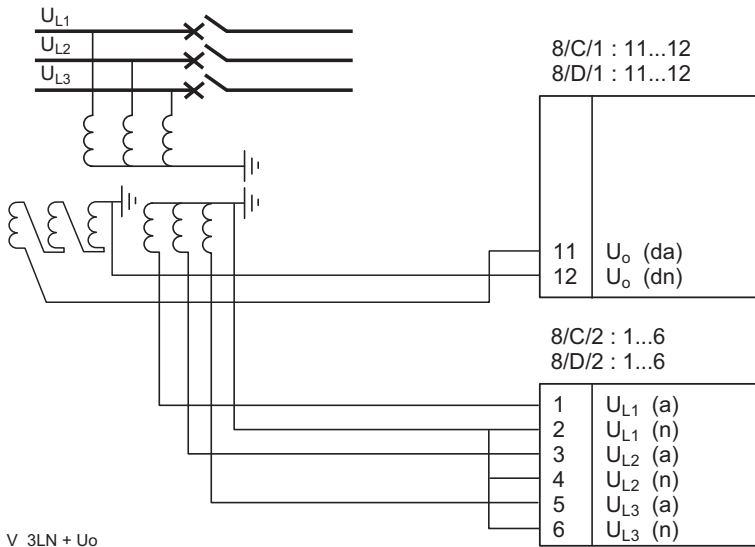

Voltage measuring mode: **3LN+U₀**

This connection is typically used for feeder and motor protection schemes.

- Voltages measured by VTs: U_{L1}, U_{L2}, U_{L3}, U_o
- Values calculated: U_{L12}, U_{L23}, U_{L31}, U₁, U₂, U_{2/U1}, f
- Measurements available: All
- Protection functions available: All except synchrocheck

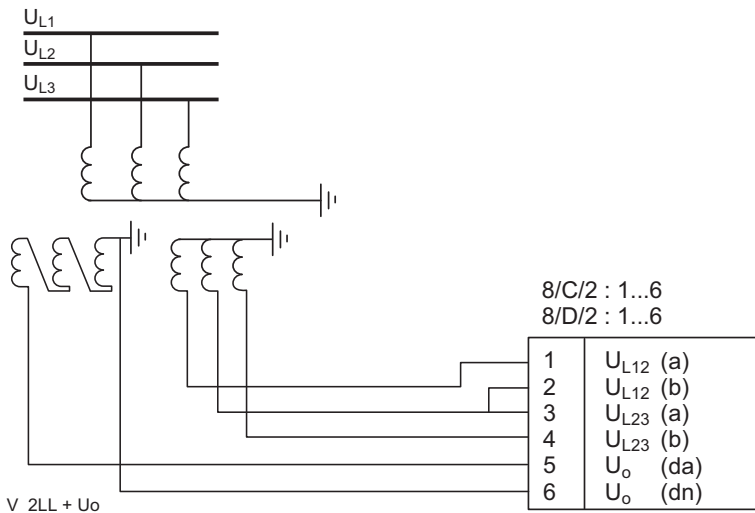

Voltage measuring mode: **2LL+U₀**

Connection of two line-to-line and residual voltage measurement scheme.

- Voltages measured by VTs: U_{L12}, U_{L23}, U_o
- Values calculated: U_{L31}, U_{L1}, U_{L2}, U_{L3}, U₁, U₂, U_{2/U1}, f
- Measurements available: All
- Protection functions available: All except synchrocheck

4.10 Direction of power and current

Figure 4.6 shows the concept of three phase current direction and sign of $\cos\phi$ and power factor PF. Figure 4.7 shows the same concepts, but on a PQ-power plane.

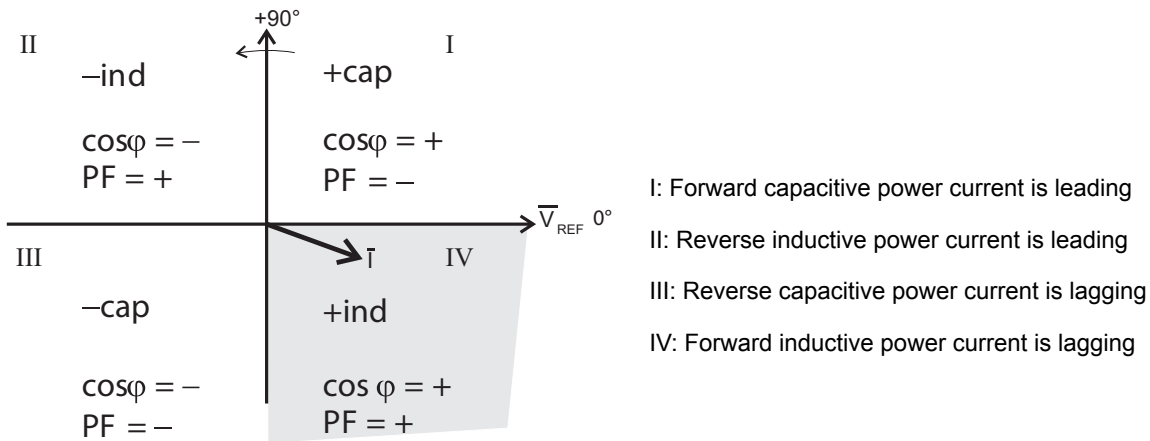

Figure 4.6: Quadrants of voltage/current phasor plane

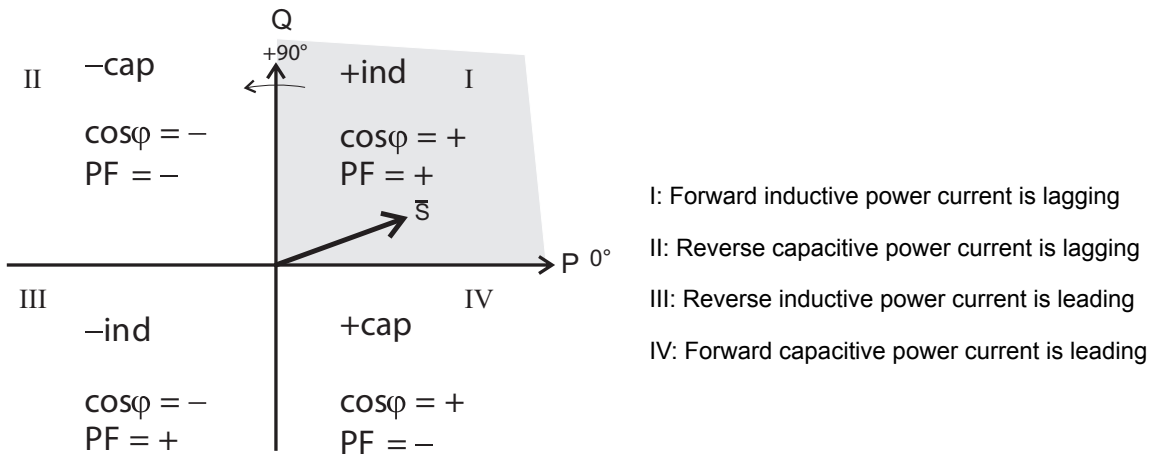

Figure 4.7: Quadrants of power plane

Table 4.9: Power quadrants

Power quadrant	Current related to voltage	Power direction	$\cos\phi$	Power factor PF
+ inductive	Lagging	Forward	+	+
+ capacitive	Leading	Forward	+	-
- inductive	Leading	Reverse	-	+
- capacitive	Lagging	Reverse	-	-

4.11 Symmetric components

In a three phase system, the voltage or current phasors may be divided in symmetric components according C. L. Fortescue (1918). The symmetric components are:

- Positive sequence 1
- Negative sequence 2
- Zero sequence 0

Symmetric components are calculated according the following equations:

$$\begin{bmatrix} \underline{S}_0 \\ \underline{S}_1 \\ \underline{S}_2 \end{bmatrix} = \frac{1}{3} \begin{bmatrix} 1 & 1 & 1 \\ 1 & \underline{a} & \underline{a}^2 \\ 1 & \underline{a}^2 & \underline{a} \end{bmatrix} \begin{bmatrix} \underline{U} \\ \underline{V} \\ \underline{W} \end{bmatrix}$$

\underline{S}_0 = zero sequence component

\underline{S}_1 = positive sequence component

\underline{S}_2 = negative sequence component

$$\underline{a} = 1 \angle 120^\circ = -\frac{1}{2} + j\frac{\sqrt{3}}{2}, \text{ a phasor rotating constant}$$

\underline{U} = phasor of phase L1 (phase current)

\underline{V} = phasor of phase L2

\underline{W} = phasor of phase L3

4.12 Primary secondary and per unit scaling

Many measurement values are shown as primary values although the relay is connected to secondary signals. Some measurement values are shown as relative values - per unit or per cent. Almost all pick-up setting values are using relative scaling.

The scaling is done using the given CT, VT in feeder mode and furthermore motor name plate values in motor mode.

The following scaling equations are useful when doing secondary testing.

4.12.1 Current scaling

NOTE: The rated value of the device's current input, for example 5 A or 1A, does not have any effect in the scaling equations, but it defines the measurement range and the maximum allowed continuous current. See Table 11.1 for details.

Primary and secondary scaling

	Current scaling
secondary → primary	$I_{PRI} = I_{SEC} \cdot \frac{CT_{PRI}}{CT_{SEC}}$
primary → secondary	$I_{SEC} = I_{PRI} \cdot \frac{CT_{SEC}}{CT_{PRI}}$

For residual current to input I_0 use the corresponding CT_{PRI} and CT_{SEC} values. For ground fault stages using I_{0Calc} signals use the phase current CT values for CT_{PRI} and CT_{SEC} .

Examples:

1. Secondary to primary

$$CT = 500 / 5$$

Current to the relay's input is 4 A.

$$\Rightarrow \text{Primary current is } I_{PRI} = 4 \times 500 / 5 = 400 \text{ A}$$

2. Primary to secondary

$$CT = 500 / 5$$

The relay displays $I_{PRI} = 400 \text{ A}$

$$\Rightarrow \text{Injected current is } I_{SEC} = 400 \times 5 / 500 = 4 \text{ A}$$

Per unit [pu] scaling

For phase currents

$$1 \text{ pu} = 1 \times I_{\text{MODE}} = 100 \%, \text{ where}$$

I_{MODE} is the rated current according to the mode. See Chapter 1.6 Abbreviations

For residual currents and Arcl> stage:

1 pu = 1 x CT_{SEC} for secondary side and 1 pu = 1 x CT_{PRI} for primary side.

	Phase current scaling excluding Arcl> stage	Residual current (3I ₀) scaling
secondary → per unit	$I_{PU} = \frac{I_{SEC} \cdot CT_{PRI}}{CT_{SEC} \cdot I_{MODE}}$	$I_{PU} = \frac{I_{SEC}}{CT_{SEC}}$
per unit → secondary	$I_{SEC} = I_{PU} \cdot CT_{SEC} \cdot \frac{I_{MODE}}{CT_{PRI}}$	$I_{SEC} = I_{PU} \cdot CT_{SEC}$

Examples:

1. **Secondary to per unit for Arcl>**

$$CT = 750 / 5$$

Current injected to the relay's inputs is 7 A.

$$\text{Per unit current is } I_{PU} = 7 / 5 = 1.4 \text{ pu} = 140 \%$$

2. **Secondary to per unit for phase currents excluding Arcl>**

$$CT = 750/5$$

$$I_{\text{MODE}} = 525 \text{ A}$$

Current injected to the relay's inputs is 7 A.

$$\text{Per unit current is } I_{PU} = 7 \times 750 / (5 \times 525) = 2.00 \text{ pu} = 2.00 \times I_{\text{MODE}} = 200 \%$$

3. **Per unit to secondary for Arcl>**

$$CT = 750 / 5$$

The device setting is 2 pu = 200 %.

$$\text{Secondary current is } I_{SEC} = 2 \times 5 = 10 \text{ A}$$

4. Per unit to secondary for phase currents

$$CT = 750 / 5$$

$$I_{MODE} = 525 \text{ A}$$

The relay setting is $2 \times I_{MODE} = 2 \text{ pu} = 200 \%$.

Secondary current is $I_{SEC} = 2 \times 5 \times 525 / 750 = 7 \text{ A}$

5. Secondary to per unit for residual current

Input is I_{01} .

$$CT_0 = 50 / 1$$

Current injected to the relay's input is 30 mA.

Per unit current is $I_{PU} = 0.03 / 1 = 0.03 \text{ pu} = 3 \%$

6. Per unit to secondary for residual current

Input is I_{01} .

$$CT_0 = 50 / 1$$

The relay setting is $0.03 \text{ pu} = 3 \%$.

Secondary current is $I_{SEC} = 0.03 \times 1 = 30 \text{ mA}$

7. Secondary to per unit for residual current

Input is I_{0Calc} .

$$CT = 750 / 5$$

Currents injected to the relay's I_{L1} input is 0.5 A.

$$I_{L2} = I_{L3} = 0.$$

Per unit current is $I_{PU} = 0.5 / 5 = 0.1 \text{ pu} = 10 \%$

8. Per unit to secondary for residual current

Input is I_{0Calc} .

$$CT = 750 / 5$$

The relay setting is $0.1 \text{ pu} = 10 \%$.

If $I_{L2} = I_{L3} = 0$, then secondary current to I_{L1} is

$$I_{SEC} = 0.1 \times 5 = 0.5 \text{ A}$$

4.12.2 Voltage scaling for analogue module C, D, W

Primary/secondary scaling of line-to-line voltages

	Line-to-line voltage scaling	
	Voltage measurement mode = "2LL+U ₀ "	Voltage measurement mode = "3LN"
secondary → primary	$U_{PRI} = U_{SEC} \cdot \frac{VT_{PRI}}{VT_{SEC}}$	$U_{PRI} = \sqrt{3} \cdot U_{SEC} \cdot \frac{VT_{PRI}}{VT_{SEC}}$
primary → secondary	$U_{SEC} = U_{PRI} \cdot \frac{VT_{SEC}}{VT_{PRI}}$	$U_{SEC} = \frac{U_{PRI}}{\sqrt{3}} \cdot \frac{VT_{SEC}}{VT_{PRI}}$

Examples:

- Secondary to primary. Voltage measurement mode is "2LL+U₀"**
 VT = 12000/110
 Voltage connected to the device's input U_A or U_B is 100 V.
 => Primary voltage is U_{PRI} = 100x12000/110 = 10909 V.
- Secondary to primary. Voltage measurement mode is "3LN"**
 VT = 12000/110
 Three phase symmetric voltages connected to the device's inputs U_A, U_B and U_C are 57.7 V.
 => Primary voltage is U_{PRI} = $\sqrt{3}$ x58x12000/110 = 10902 V
- Primary to secondary. Voltage measurement mode is "2LL+U₀"**
 VT = 12000/110
 The relay displays U_{PRI} = 10910 V.
 => Secondary voltage is U_{SEC} = 10910x110/12000 = 100 V
- Primary to secondary. Voltage measurement mode is "3LN"**
 VT = 12000/110
 The relay displays U₁₂ = U₂₃ = U₃₁ = 10910 V.
 => Symmetric secondary voltages at U_A, U_B and U_C are U_{SEC} = 10910/ $\sqrt{3}$ x110/12000 = 57.7 V.

Per unit [pu] scaling of line-to-line voltages

One per unit = 1 pu = $1 \times U_N = 100\%$, where U_N = rated voltage of the VT.

	Line-to-line voltage scaling	
	Voltage measurement mode = "2LL+U ₀ ", "1LL+U ₀ /LLy", "2LL/LLy", "LL/LLy/LLz"	Voltage measurement mode = "3LN"
secondary → per unit	$U_{PU} = \frac{U_{SEC}}{VT_{SEC}} \cdot \frac{VT_{PRI}}{U_N}$	$U_{PU} = \sqrt{3} \cdot \frac{U_{SEC}}{VT_{SEC}} \cdot \frac{VT_{PRI}}{U_N}$
per unit → secondary	$U_{SEC} = U_{PU} \cdot VT_{SEC} \cdot \frac{U_N}{VT_{PRI}}$	$U_{SEC} = U_{PU} \cdot \frac{VT_{SEC}}{\sqrt{3}} \cdot \frac{U_N}{VT_{PRI}}$

Examples:

- 1. Secondary to per unit. Voltage measurement mode is "2LL+U₀"**
 VT = 12000/110
 Voltage connected to the device's input U_A or U_B is 110 V.
 => Per unit voltage is $U_{PU} = 110/110 = 1.00$ pu = $1.00 \times U_N = 100\%$
- 2. Secondary to per unit. Voltage measurement mode is "3LN"**
 VT = 12000/110
 Three symmetric phase-to-neutral voltages connected to the device's inputs U_A , U_B and U_C are 63.5 V
 => Per unit voltage is $U_{PU} = \sqrt{3} \times 63.5 / 110 \times 12000 / 11000 = 1.00$ pu = $1.00 \times U_N = 100\%$
- 3. Per unit to secondary. Voltage measurement mode is "2LL+U₀"**
 VT = 12000/110
 The relay displays 1.00 pu = 100 %.
 => Secondary voltage is $U_{SEC} = 1.00 \times 110 \times 11000 / 12000 = 100.8$ V
- 4. Per unit to secondary. Voltage measurement mode is "3LN"**
 VT = 12000/110
 $U_N = 11000$ V
 The relay displays 1.00 pu = 100 %.
 => Three symmetric phase-to-neutral voltages connected to the device 's inputs U_A , U_B and U_C are
 $U_{SEC} = 1.00 \times 110 / \sqrt{3} \times 11000 / 12000 = 58.2$ V

Per unit [pu] scaling of zero sequence voltage

	Zero-sequence voltage (U_0) scaling	
	Voltage measurement mode = "2LL+ U_0 ", "1LL+ U_0 /LLy"	Voltage measurement mode = "3LN"
secondary -> per unit	$U_{PU} = \frac{U_{SEC}}{U_{0SEC}}$	$U_{PU} = \frac{1}{VT_{SEC}} \cdot \frac{ \bar{U}_a + \bar{U}_b + \bar{U}_c _{SEC}}{\sqrt{3}}$
per unit -> secondary	$U_{SEC} = U_{PU} \cdot U_{0SEC}$	$ \bar{U}_a + \bar{U}_b + \bar{U}_c _{SEC} = \sqrt{3} \cdot U_{PU} \cdot VT_{SEC}$

Examples:

1. **Secondary to per unit. Voltage measurement mode is "2LL+ U_0 "**

$U_{0SEC} = 110$ V (This is a configuration value corresponding to U_0 at full earth fault.)

Voltage connected to the device's input U_C is 22 V.

=> Per unit voltage is $U_{PU} = 22/110 = 0.20$ pu = 20 %

2. **Secondary to per unit. Voltage measurement mode is "3LN"**

$VT = 12000/110$

Voltage connected to the device's input U_A is 38.1 V, while

$U_A = U_B = 0$.

=> Per unit voltage is $U_{PU} = (38.1+0+0)/(\sqrt{3} \times 110) = 0.20$ pu = 20 %

3. **Per unit to secondary. Voltage measurement mode is "2LL+ U_0 "**

$U_{0SEC} = 110$ V (This is a configuration value corresponding to U_0 at full earth fault.)

The device displays $U_0 = 20$ %.

=> Secondary voltage at input U_C is $U_{SEC} = 0.20 \times 110 = 22$ V

4. **Per unit to secondary. Voltage measurement mode is "3LN"**

$VT = 12000/110$

The device displays $U_0 = 20$ %.

=> If $U_B = U_C = 0$, then secondary voltages at U_A is

$U_{SEC} = \sqrt{3} \times 0.2 \times 110 = 38.1$ V

5 Control functions

5.1 Output relays

The output relays are also called digital outputs. Trip contacts can be controlled by using relay output matrix or logic function. Also forced control is possible. When using force controlling it has to be first enabled in the “relays” menu.

The output relays are also called digital outputs. Any internal signal can be connected to the output relays using "OUTPUT MATRIX". An output relay can be configured as latched or non-latched.

The "output matrix" and "relays" menus represents the state (de-energized / energized) of the output relay's coil. For example a bright green vertical line in "output matrix" and a logical "1" in "relays" menu represents the energized state of the coil. The same principle applies for both NO and NC type output relays. The actual position (open / closed) of the output relay's contacts in coil's de-energized and energized state depends on the type (NO/NC) of the output relay. De-energized state of the coil corresponds to the normal state of the contacts. An output relay can be configured as latched or non-latched. Latched relay contacts can be set free by pressing the “enter” key of the device or by releasing from VAMPSET setting tool.

The difference between trip contacts and signal contacts is the DC breaking capacity. The contacts are **single pole single throw (SPST)** normal open type (NO), except signal relay A1 which has change over contact **single pole double throw (SPDT)**.

In addition to this VAMP 300G has so called heavy duty outputs available in power supply module C and D. See Chapter 11 Technical data for more details.

OUTPUT MATRIX

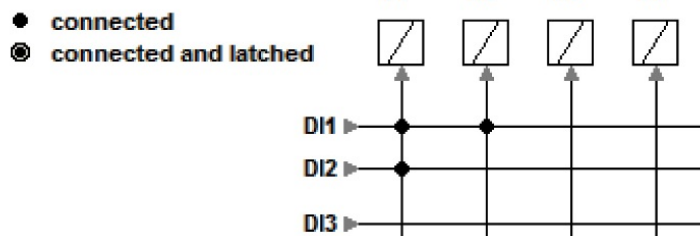

Figure 5.1: Trip contacts can be connected to protection stages or other similar purpose in “output matrix” menu.

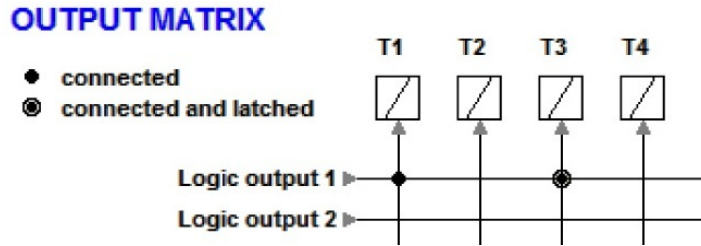

Figure 5.2: Trip contacts can be assigned directly to outputs of logical operators.

Notice the difference between latched and non-latched connection. Logic output will be assigned automatically in output matrix as well when logic is built.

Trip contacts can be controlled by using relay output matrix or logic function. Also forced control is possible. When using force controlling it has to be first enabled in the “relays” menu.

The position of the contact can be checked in “output matrix” and “relays” menu. An output relay can be configured as latched or non-latched. Latched relay contacts can be set free by releasing from VAMPSET setting tool or pressing the “releasing all latches” on the device. See pictures or instructions below.

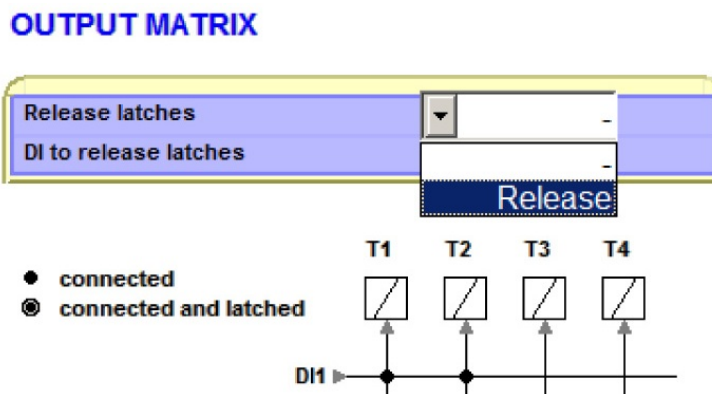

Figure 5.3: Latched output matrix signals released by using VAMPSET setting tool.

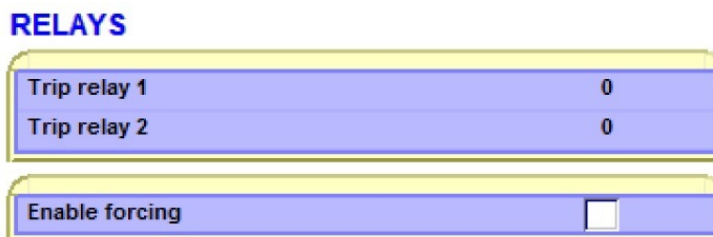

Figure 5.4: Trip contact can be viewed, forced to operate in “relays” menu. Logical “0” means that the output is not energized and logical “1” states that output is set active.

Release all latches (while correct password is enabled)

1. Press  .
 - To release the latches, press  .
 - To release, choose “Release” parameter and press  .

Default numbering of DI / DO

Every option card and slot has default numbering. Below is an example of model VAMP 300G CGGAT-SACDA-A1 showing default numbering of DO.

User can change numbering of the following option cards - slot 2, 3, 4, 5: G, I. More information in Chapter 5.4 Matrix.

Default digital output numbering is also shown in corresponding VAMPSET menus.

1. T1, T9 – 12, A1, SF
2. T13 – 16
3. T17 – 20

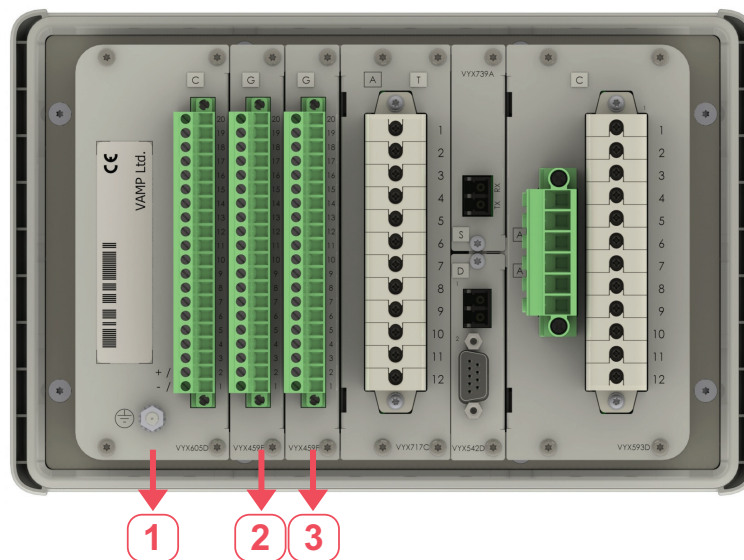

Figure 5.5: Default numbering of model VAMP 300G CGGAT-SACDA-A1



Power supply card outputs are not visible in 'relay config' menu

Table 5.1: Parameters of output relays

Parameter	Value	Unit	Description	Note
T1 – Tx the available parameter list depends on the number and type of the I/O cards.	0		Status of trip output relay	F
	1			
A1	0		Status of alarm output relay	F
	1			
SF	0		Status of the SF relay	F
	1			
Force	On		Force flag for output relay forcing for test purposes. This is a common flag for all output relays and detection stage status, too. Any forced relay(s) and this flag are automatically reset by a 5-minute timeout.	Set
	Off			
NAMES for OUTPUT RELAYS (editable with VAMPSET only)				
Description	String of max. 32 characters		Names for DO on VAMPSET screens. Default is "Trip relay n", n=1 – x or "Signal relay n", n=1	Set

F = Editable when force flag is on. Set = An editable parameter (password needed).

5.2 Digital inputs

Digital inputs are available for control purposes. The number of available inputs depends on the number and type of option cards.

The polarity –g normal open (NO) / normal closed (NC) – and a delay can be configured according the application by using the local HMI or VAMPSET.

Digital inputs can be used in many operations. The status of the input can be checked in relay “output matrix” and “digital inputs” menu. Digital inputs makes possible to change group, block/enable/disable functions, to program logics, indicate object status, etc.

The digital inputs do require an external control voltage (ac or dc). Digital input will be activated after activation voltage exceeds. Deactivation follows when the voltage drops below threshold limit. Activation voltage level of digital inputs can be selected in order code when such option cards are equipped.

OUTPUT MATRIX

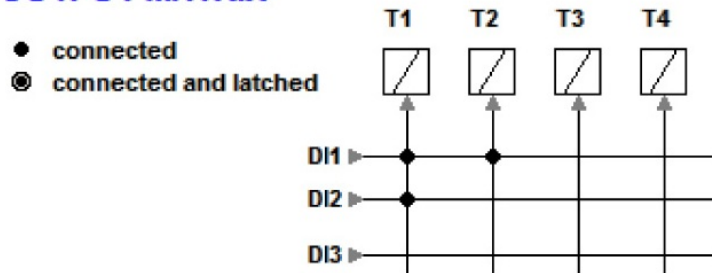

Figure 5.6: Digital inputs can be connected to trip contacts or other similar purpose in “output matrix” menu.

LOGIC [3%]

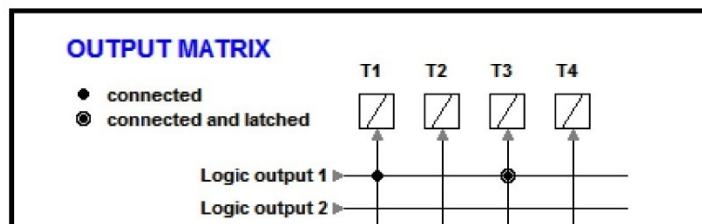
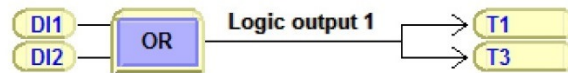

Figure 5.7: Digital inputs can be assigned directly to inputs/outputs of logical operators.

Notice the difference between latched and non-latched connection. Logic output will be assigned automatically in output matrix as well when logic is built.

NAMES for DIGITAL INPUTS

Input	Slot	Label	Description
1	2	DI1	Digital input 1
2	2	DI2	Digital input 2
3	2	DI3	Digital input 3
4	2	DI4	Digital input 4
5	2	DI5	Digital input 5
6	2	DI6	Digital input 6
7	3	DI7	Digital input 7
8	3	DI8	Digital input 8
9	3	DI9	Digital input 9
10	3	DI10	Digital input 10
11	3	DI11	Digital input 11
12	3	DI12	Digital input 12

Figure 5.8: Digital inputs can be viewed, named and changed between NO/NC in “Digital inputs” menu.

In case that inputs are energized by using AC voltage “mode” has to be selected as AC.

All essential information of digital inputs can be found from the same location “digital inputs” menu. DI on/off events and alarm display (pop-up) can be enabled and disabled in “digital inputs” menu. Individual operation counters are located in the same menu as well.

Label and description texts can be edited with VAMPSET according the application. Labels are the short parameter names used on the local panel and descriptions are the longer names used by VAMPSET.

Digital input activation thresholds are hardware selectable.

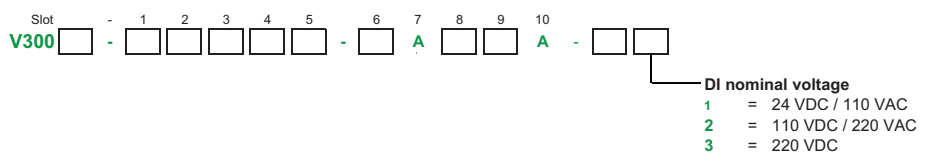

Figure 5.9: VAMP 300 order code.

Digital input delay determines the activation and de-activation delay for the input. See picture below to indicate how DI behaves when the delay is set to 1.0 seconds.

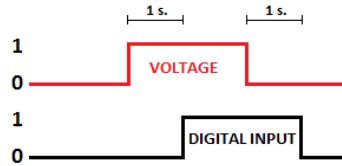

Figure 5.10: Digital inputs behaviour when delay is set to one second.

Table 5.2: Parameters of digital inputs

Parameter	Value	Unit	Description	Note
Mode	DC, AC		Used voltage of digital inputs	Set
Input	DI1 – DIx		Number of digital input. The available parameter list depends on the number and type of the I/O cards.	
Slot	2 – 6		Card slot number where option card is installed.	
State	0, 1		Status of digital input 1 – digital input x.	
Polarity	NO		For normal open contacts (NO). Active edge is 0 -> 1	Set
	NC		For normal closed contacts (NC) Active edge is 1 -> 0	
Delay	0.00 – 60.00	s	Definite delay for both on and off transitions	Set
On event	On		Active edge event enabled	Set
	Off		Active edge event disabled	
Off event	On		Inactive edge event enabled	Set
	Off		Inactive edge event disabled	
Alarm display	no		No pop-up display	Set
	yes		Alarm pop-up display is activated at active DI edge	
Counters	0 – 65535		Cumulative active edge counter	(Set)
NAMES for DIGITAL INPUTS (editable with VAMPSET only)				
Label	String of max. 10 characters		Short name for DIs on the local display Default is "DI1 - DIx". x is the maximum number of the digital input.	Set
Description	String of max. 32 characters		Long name for DIs. Default is "Digital input 1 – Digital input x". x is the maximum number of the digital input.	Set

Set = An editable parameter (password needed).

Every option card and slot has default numbering. When making any changes to numbering, please read setting file after VAMP 300G has rebooted.

Below is an example of model VAMP 300G CGGAT-SACDA-A1 showing default numbering of DI.

User can change numbering of the following option cards - slot 2, 3, 4, 5: G, I. More information in Chapter 5.4 Matrix.

Default digital input numbering is also shown in corresponding VAMPSET menus.

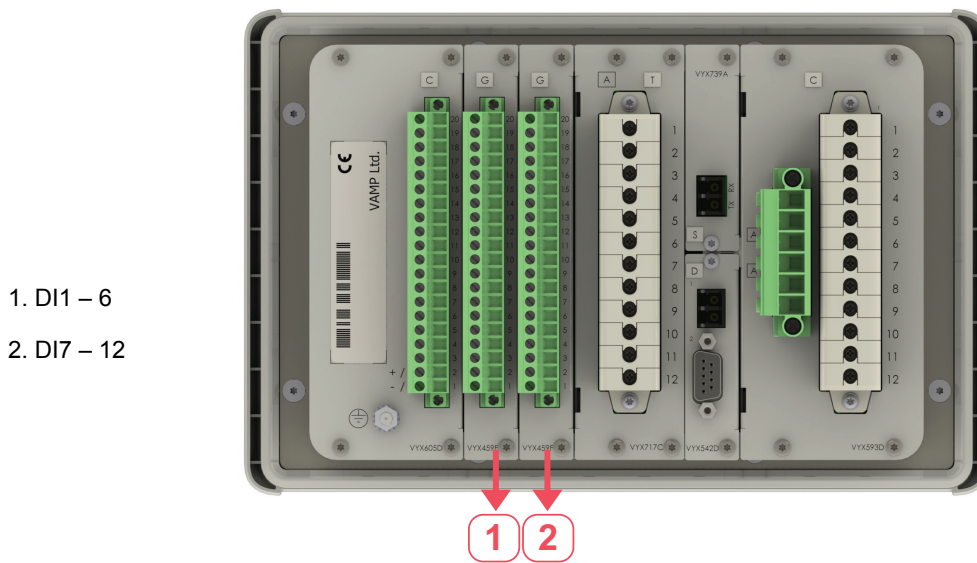

Figure 5.11: Default numbering of model VAMP 300G CCGAT-SACDA-A1

DIGITAL INPUTS CONFIG

6DI+4DO

Input	SLOT2	SLOT3
1	DI1	DI7
2	DI2	DI8
3	DI3	DI9
4	DI4	DI10
5	DI5	DI11
6	DI6	DI12

Set default values No

5.3 Virtual inputs and outputs

There are virtual inputs and virtual outputs, which can in many places be used like their hardware equivalents except that they are only located in the memory of the device. The virtual inputs acts like normal digital inputs. The state of the virtual input can be changed from local display, communication bus and from VAMPSET. For example setting groups can be changed using virtual inputs.

Virtual inputs can be used in many operations. The status of the input can be checked in “output matrix” and “virtual inputs” menu. Status is also visible on local mimic display if so selected. Virtual inputs can be selected to be operated trough function buttons F1 and F2, trough local mimic or simply by using the virtual input menu.

Virtual inputs makes possible to change group, block/enable/disable functions, to program logics and other similar to digital inputs.

Activation and reset delay of input is approximately 5ms. See specification below:

Table 5.3: Virtual input and output

Number of inputs	4
Number of outputs	6
Activation time / Reset time	< 5 ms

OUTPUT MATRIX

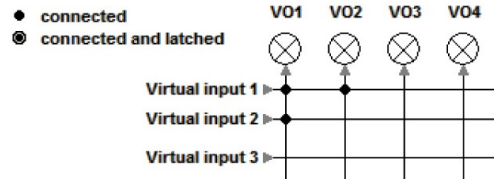

Figure 5.12: Virtual inputs and outputs can be used for many purpose in “output matrix” -menu.

LOGIC [13%]

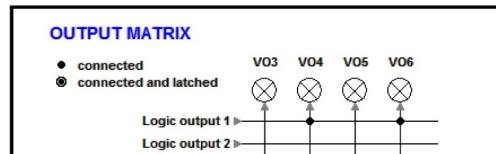
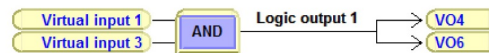

Figure 5.13: Virtual inputs and outputs can be assigned directly to inputs/outputs of logical operators.

Notice the difference between latched and non-latched connection.

INPUT SIGNALS > VIRTUAL INPUT

The virtual inputs do act like digital inputs, but there are no physical contacts. These can be controlled via the local HMI and communication protocols. Virtual inputs are shown in the output matrix and the block matrix. Virtual inputs can be used with the user's programmable logic and to change the active setting group etc.

VIRTUAL INPUTS

Virtual input 1	0
Virtual input 2	0
Virtual input 3	0
Virtual input 4	0
Event enabling	<input checked="" type="checkbox"/>

VIRTUAL INPUTS

VIRTUAL INPUTS		
Input	Label	Description
1	VI1	Virtual input 1
2	VI2	Virtual input 2
3	VI3	Virtual input 3
4	VI4	Virtual input 4

Figure 5.14: Virtual inputs can be viewed, named and controlled in “Virtual inputs” -menu.

Table 5.4: Parameters of virtual inputs

Parameter	Value	Unit	Description	Set
VI1-VI4	0 1		Status of virtual input	
Events	On Off		Event enabling	Set
NAMES for VIRTUAL INPUTS (editable with VAMPSET only)				
Label	String of max. 10 characters		Short name for VIs on the local display Default is "VI n", n = 1 – 4	Set
Description	String of max. 32 characters		Long name for VIs. Default is "Virtual input n", n = 1 – 4	Set

Set = An editable parameter (password needed).

OUTPUT SIGNALS > VIRTUAL OUTPUT

The virtual outputs do act like output relays, but there are no physical contacts. Virtual outputs are shown in the output matrix and the block matrix. Virtual outputs can be used with the user's programmable logic and to change the active setting group etc.

VIRTUAL OUTPUTS

Virtual output 1	0
Virtual output 2	0
Virtual output 3	0
Virtual output 4	0
Virtual output 5	0
Virtual output 6	0
Event enabling	<input checked="" type="checkbox"/>

Enable forcing

VIRTUAL OUTPUTS

VIRTUAL OUTPUTS		
Input	Label	Description
1	VO1	Virtual output 1
2	VO2	Virtual output 2
3	VO3	Virtual output 3
4	VO4	Virtual output 4
5	VO5	Virtual output 5
6	VO6	Virtual output 6

Figure 5.15: Virtual Outputs can be viewed, named and force controlled in “Virtual outputs” -menu. Virtual outputs menu is located under the “device menu” leaflet -> output signals. Virtual output contacts are in “DO” -menu when 64 x 128 LCD display is installed.

Table 5.5: Parameters of virtual outputs

Parameter	Value	Unit	Description	Set
VO1-VO6	0 1		Status of virtual output	F
Events	On Off		Event enabling	Set
NAMES for VIRTUAL OUTPUTS (editable with VAMPSET only)				
Label	String of max. 10 characters		Short name for VOs on the local display Default is "VO n ", $n=1 - 6$	Set
Description	String of max. 32 characters		Long name for VOs. Default is "Virtual output n ", $n=1 - 6$	Set

Set = An editable parameter (password needed). F = Editable when force flag is on.

5.4 Matrix

5.4.1 Output matrix

By means of the output matrix, the output signals of the various protection stages, digital inputs, logic outputs and other internal signals can be connected to the output relays, virtual outputs, etc.

There are general purpose LED indicators – "A", "B", "C" to "N" – available for customer-specific indications on the front panel. Their usage is define in a separate LED MATRIX.

Furthermore there are two LED indicators specified for keys F1 and F2. In addition, the triggering of the disturbance recorder (DR) and virtual outputs are configurable in the output matrix.

An output relay or indicator LED can be configured as latched or non-latched. A non-latched relay follows the controlling signal. A latched relay remains activated although the controlling signal releases.

There is a common "release all latches" signal to release all the latched relays. This release signal resets all the latched output relays and indicators with CPU and FPGA control. The reset signal can be given via a digital input, via HMI or through communication. The selection of the input is done with the VAMPSET software under the menu "Release output matrix latches".

OUTPUT MATRIX

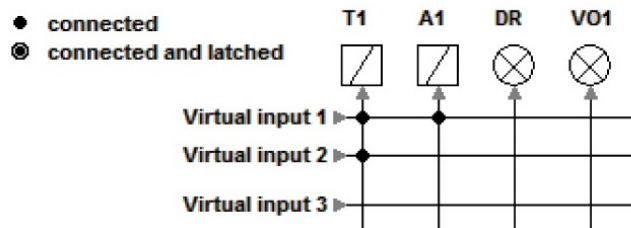

Figure 5.16: Trip and alarm relays together with virtual outputs can be assigned in output matrix. Also automatic triggering of disturbance recorder is done in output matrix.

5.4.2 Blocking matrix

By means of a blocking matrix, the operation of any protection stage (except the arc protection stages) can be blocked. The blocking signal can originate from the digital inputs or it can be a start or trip signal from a protection stage or an output signal from the user's programmable logic. In the Figure 5.17, an active blocking is indicated with a black dot (•) in the crossing point of a blocking signal and the signal to be blocked.

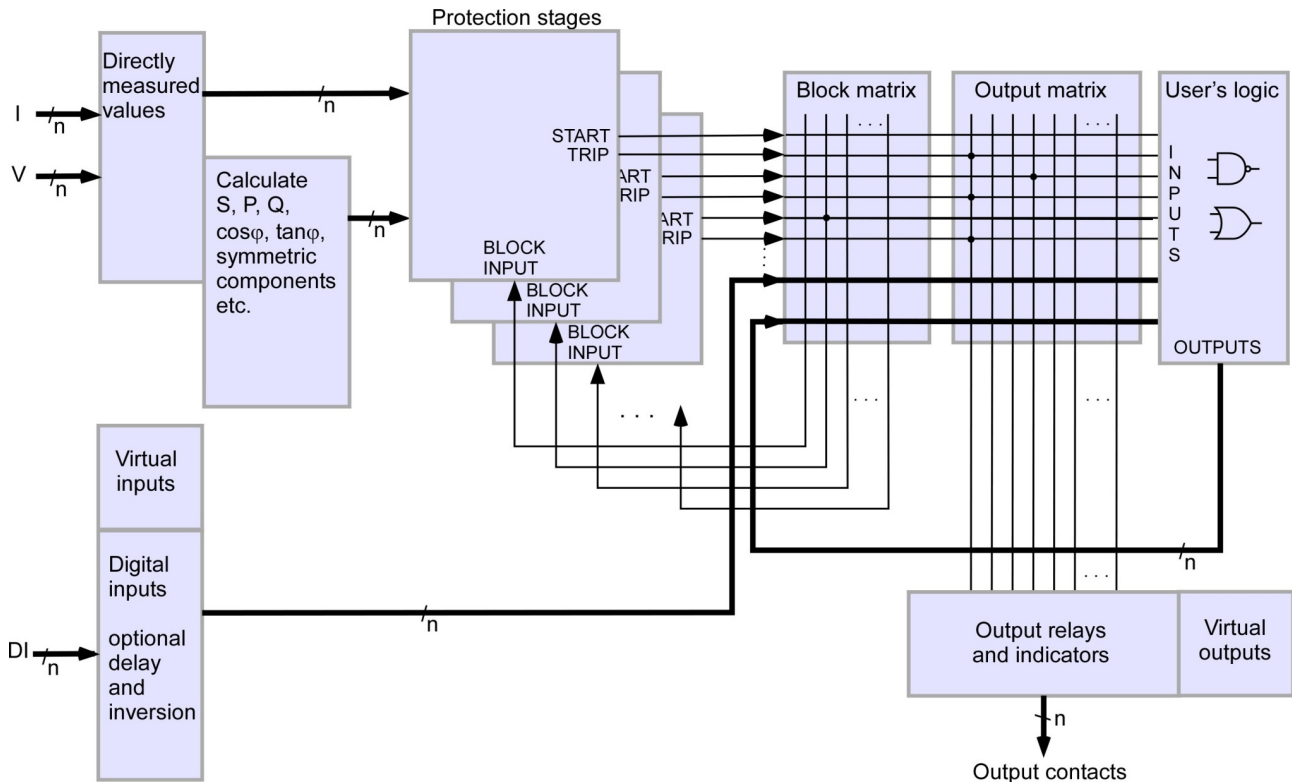

Figure 5.17: Blocking matrix and output matrix

NOTE: Blocking matrix can not be used to block the arc protection stages.

BLOCK MATRIX

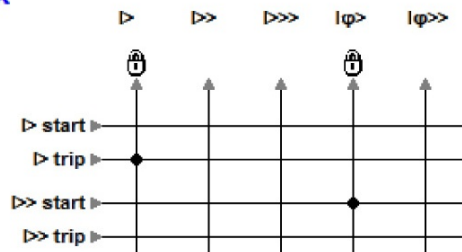

Figure 5.18: All protection stages (except Arc stages) can be blocked in block matrix.

NOTICE

RISK OF NUISANCE TRIPPING

- The blocking matrix is dynamically controlled by selecting and deselecting protection stages.
- Activate the protection stages first, then store the settings in a relay. After that, refresh the blocking matrix before configuring it.

Failure to follow these instructions can result in unwanted shutdown of the electrical installation.

5.4.3 LED matrix

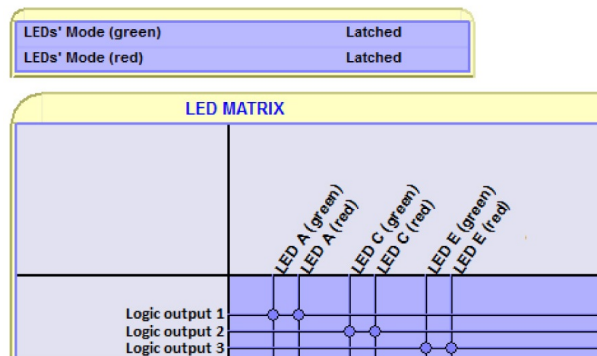

Figure 5.19: LEDs will be assigned in the “LED matrix” -menu. It is not possible to control LEDs directly with logics.

Normal connection

When connection is normal the assigned LED will be active when the control signal is active. After deactivation, the LED will turn off. LED activation and deactivation delay when controlled is approximately 10ms.

Latched connection

Latched LED will activate when the control signal activates but will remain lit even when the control signal deactivates. Latched LEDs can be released by pressing enter key.

Blink Latched connection

When connection is “BlinkLatch” the assigned LED will be active and blinking as long as control signal is active. After deactivation the LED remains latched and blinking. Latch can be released by pressing

OK (see Chapter 2.2 Local HMI).

LED test sequence

In order to run LED test sequence, open user password first.

User can test the functionality of LEDs if needed. To start the test sequence, press "info" button and the "" on the local HMI. The IED will test all the LEDs' functionality. The sequence can be started in all main menu windows, except the very first one.

Inputs for LEDs can be assigned in LED matrix. All 14 LEDs can be assigned as green or red. Connection can be normal, latched or blink latched. Instead of mere protection stages there are lots of functions which can be assigned to output LEDs. See the table below:

Table 5.6: Inputs for LEDs A - N

Input	LED mapping	Latch	Description	Note
Protection, Arc and programmable stages	LED A - N green or red	Normal/ Latched/ BlinkLatch	Different type of protection stages can be assigned to LEDs	Set
Digital/Virtual inputs and function buttons	LED A - N green or red	Normal/ Latched/ BlinkLatch	All different type of inputs can be assigned to LEDs	Set
Object open/close, object final trip and object failure information	LED A - N green or red	Normal/ Latched/ BlinkLatch	Information related to objects and object control	Set
Local control enabled	LED A - N green or red	Normal/ Latched/ BlinkLatch	While remote/local state is selected as local the "local control enabled" is active	Set
Logic output 1-20	LED A - N green or red	Normal/ Latched/ BlinkLatch	All logic outputs can be assigned to LEDs at the LED matrix	Set
Manual control indication	LED A - N green or red	Normal/ Latched/ BlinkLatch	When the user has controlled the objects	Set
COM 1-5 comm.	LED A - N green or red	Normal/ Latched/ BlinkLatch	When the communication port 1 - 5 is active	Set
Setting error, seldiag alarm, pwd open and setting change	LED A - N green or red	Normal/ Latched/ BlinkLatch	Self diagnostic signal	Set
GOOSE NI1-64	LED A - N green or red	Normal/ Latched/ BlinkLatch	IEC 61850 goose communication signal	Set
GOOSEERR1-16	LED A - N green or red	Normal/ Latched/ BlinkLatch	IEC 61850 goose communication signal	Set

Set = an editable parameter (password needed)

5.5 Controllable objects

The device allows controlling of six objects, that is, circuit-breakers, disconnectors and earthing switches. Controlling can be done by "select-execute" or "direct control" principle.

The object block matrix and logic functions can be used to configure interlocking for a safe controlling before the output pulse is issued. The objects 1 – 6 are controllable while the objects 7 – 8 are only able to show the status.

Controlling is possible by the following ways:

- through the local HMI
- through a remote communication
- through a digital input
- through the object control buttons
- through the function key

The connection of an object to specific output relays is done via an output matrix (object 1 – 6 open output, object 1 – 6 close output). There is also an output signal “Object failed”, which is activated if the control of an object is not completed.

Object states

Each object has the following states:

Setting	Value	Description
Object state	Undefined (00)	Actual state of the object
	Open	
	Close	
	Undefined (11)	

Basic settings for controllable objects

Each controllable object has the following settings:

Setting	Value	Description
DI for ‘obj open’	None, any digital input, virtual input or virtual output	Open information
DI for ‘obj close’		Close information
DI for ‘obj ready’		Ready information
Max ctrl pulse length	0.02 – 600 s	Pulse length for open and close commands
Completion timeout	0.02 – 600 s	Timeout of ready indication
Object control	Open/Close	Direct object control

If changing states takes longer than the time defined by “Max ctrl pulse length” setting, object is inoperative and “Object failure” matrix signal is set. Also undefined-event is generated. “Completion timeout” is only used for the ready indication. If “DI for ‘obj ready’” is not set, completion timeout has no meaning.

Each controllable object has 2 control signals in matrix:

Output signal	Description
Object x Open	Open control signal for the object
Object x Close	Close control signal for the object

These signals send control pulse when an object is controlled by digital input, remote bus, auto-reclose etc.

Settings for read-only objects

Setting	Value	Description
DI for 'obj open'	None, any digital input, virtual input or virtual output	Open information
DI for 'obj close'		Close information
Object timeout	0.02 – 600 s	Timeout for state changes

If changing states takes longer than the time defined by “Object timeout” setting, and “Object failure” matrix signal is set. Also undefined-event is generated.

5.5.1**Controlling with DI**

Objects can be controlled with digital input, virtual input or virtual output. There are four settings for each controllable object:

Setting	Active
DI for remote open / close control	In remote state
DI for local open / close control	In local state

If the device is in local control state, the remote control inputs are ignored and vice versa. Object is controlled when a rising edge is detected from the selected input. Length of digital input pulse should be at least 60 ms.

5.5.2**Local/Remote selection**

In Local mode, the output relays can be controlled via a local HMI, but they cannot be controlled via a remote serial communication interface. For more information, see Chapter 5.7.3 Function buttons.

In Remote mode, the output relays cannot be controlled via a local HMI, but they can be controlled via a remote serial communication interface.

The selection of the Local/Remote mode is done by using a local HMI, or via one selectable digital input. The digital input is normally used to change a whole station to a local or remote mode. The selection of the L/R digital input is done in the “Objects” menu of the VAMPSET software.

5.5.3 Controlling with I/O

VAMP 300G also has dedicated control buttons for object. (I) stands for object close and (O) controls object open command internally. Control buttons are configured in OBJECTS view.

Table 5.7: Parameters of function keys

Parameter	Value	Unit	Description	Set
Disabled	-		Green button (I) closes selected object if password is enabled	Set
Object 1 – 6	Obj1 – Obj6		Red button (O) opens selected object if password is enabled	
Mode for control buttons	Selective		Control operation needs confirmation (select-execute)	
	Direct		Control operation is done without confirmation	

5.5.4 Controlling with F1 & F2

Objects can be controlled with F1 & F2.

As default these keys are programmed to toggle F1 and F2. It is possible to configure F1 & F2 to toggle VI1 – VI4 or act as object control. Selection of the F1 and F2 function is made with the VAMPSET software under the FUNCTION BUTTONS menu.

Table 5.8: Parameters of F1, F2

Parameter	Value	Unit	Description	Set
F1 – F2	0		Function key toggles Virtual input 1 – 4 and Function button 1 – 2 between on (1) and off (0)	Set
VI1 – VI4				
ObjCtrl	1		When Object control is chosen F1 and F2 can be linked in OBJECTS to desired objects close/open command.	
PrgFnCs				

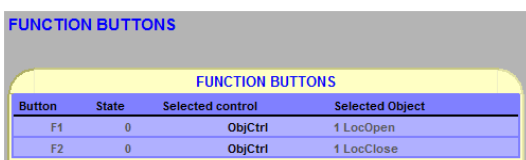

FUNCTION BUTTONS			
Button	State	Selected control	Selected Object
F1	0	ObjCtrl	1 LocOpen
F2	0	ObjCtrl	1 LocClose

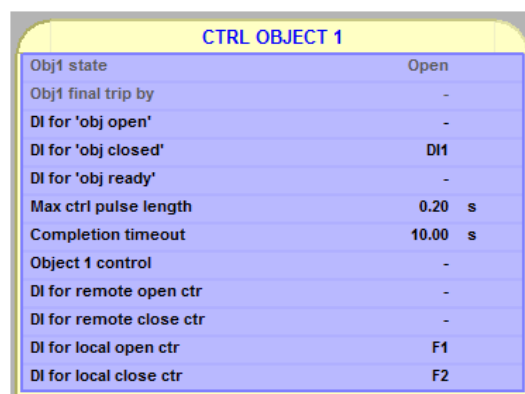

CTRL OBJECT 1	
Obj1 state	Open
Obj1 final trip by	-
DI for 'obj open'	-
DI for 'obj closed'	DI1
DI for 'obj ready'	-
Max ctrl pulse length	0.20 s
Completion timeout	10.00 s
Object 1 control	-
DI for remote open ctr	-
DI for remote close ctr	-
DI for local open ctr	F1
DI for local close ctr	F2

Selected object and control is shown in VAMPSET software under the menu "FUNCTION BUTTONS". If no object with local control is selected '-' is shown. If multiple local controls are selected for one key '?' is shown.

5.6 Logic functions

The device supports customer-defined programmable logic for boolean signals. User configurable logic can be used to create something that is not provided by the relay as a default. The logic is designed by using the VAMPSET setting tool and downloaded to the device. Functions available are:

Table 5.9: Available logic functions and their memory use

Logic functions	No. of gates reserved	Max. no. of input gates	Max. no. of logic outputs
AND	1	32 (An input gate can include any number of inputs.)	20
OR	1		
XOR	1		
AND+OR	2		
CT (count+reset)	2		
INVAND	2		
INVOR	2		
OR+AND	2		
RS (set+reset)	2		
RS_D (set+D+load+reset)	4		

Logic is made with VAMPSET setting tool. Consumed memory is dynamically shown on the configuration view in percentage. The first value indicates amount of used inputs, second amount of gates and third values shows amount of outputs consumed.

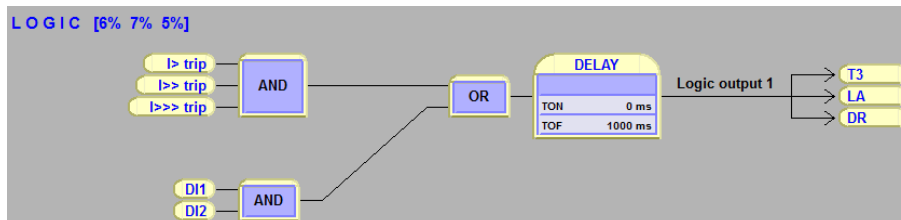

Figure 5.20: Logic can be found and modified in “logic” menu in VAMPSET setting tool

Percentages show used memory amount.

Inputs/Logical functions/Outputs- used. None of these is not allowed to exceed 100%. See guide below to learn basics of logic creation:

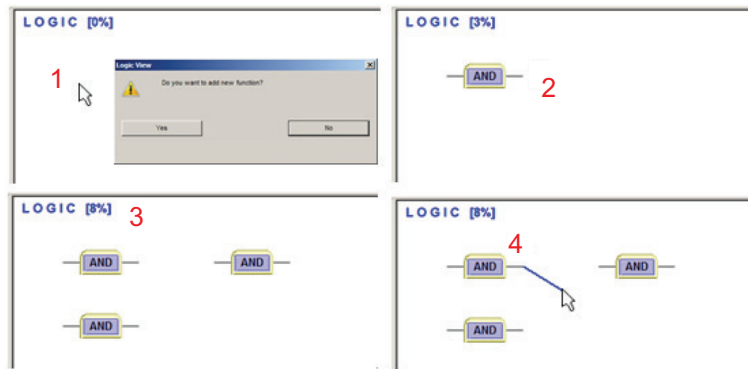

Figure 5.21: How to create logical nodes.

1. Press empty area to add a logic gate, confirm new function by pressing “Yes”.
2. Logic function is always "AND" -gate as a default.
3. While logic increases the capacity is increasing as well.
4. To joint logic functions, go on top of the output line of gate and hold down mouse left -> make the connection to other logic functions input.

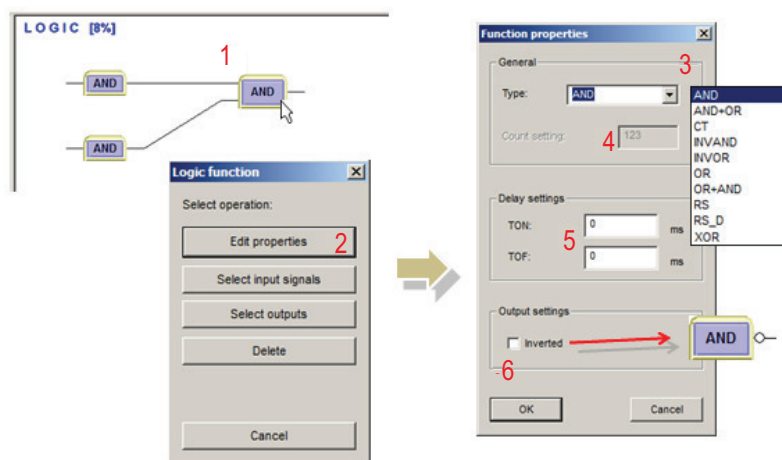

Figure 5.22: Logic creation

1. Left click on top of any logic function to activate the “Select operation” view.
2. Edit properties button opens the “Function properties” window.
3. Generally it is possible to choose the type of logic function between and/or/counter/swing -gate.
4. When counter is selected, count setting may be set here.
5. Separate delay setting for logic activation and dis-activation.
6. Possible to invert the output of logic. Inverted logic output is marked with circle.

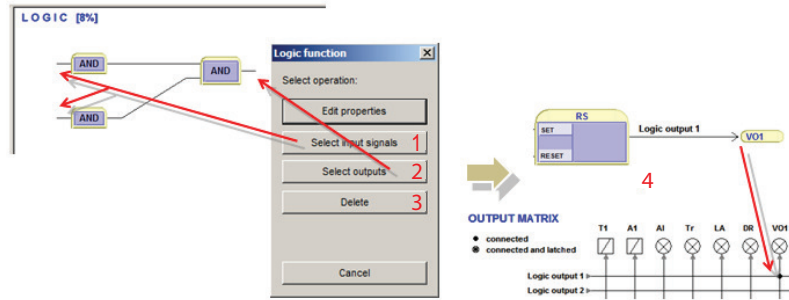

Figure 5.23: Logic creation

1. Select input signals can be done by pressing the following button or by clicking mouse left on top of the logic input line.
2. Select outputs can be done by pressing the following button or by clicking mouse left on top of the logic output line.
3. This deletes the logic function.
4. When logic is created and settings are written to the device the unit requires a restart. After restarting the logic output is automatically assigned in output matrix as well.

NOTE: Whenever writing new logic to the device the unit has to be restarted.

5.7 Local panel

VAMP 300G has one LCD matrix display.

All the main menus are located on the left side and to get in to certain submenu, user has to move up and down the main menus.

5.7.1 Mimic display

VAMP 300G has a mimic display enabled as a default. Mimic can be modified according the application or disabled if not needed. Mimic display can be configured only by using VAMPSET setting tool. It is not possible to create mimic by using the local HMI of the device.

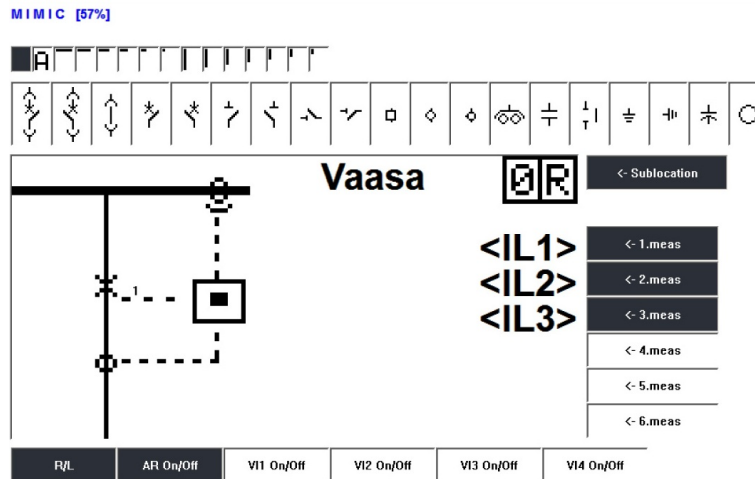

Figure 5.24: It is possible to modify local panel mimic in “Mimic” menu. Mimic menu is located under the “device menu” leaflet. In order to have mimic menu, it has to be enabled. Mimic menu can be enabled in “local panel configuration” menu. Mimic cannot be enabled/disabled by using the local panel of the device.



Figure 5.25: Creating mimic is completed by using different options below.

- A) Percentage indicates the amount of memory used by the mimic. 100% is the maximum.
- B) Clear object/drawings by going on top of it or clear the whole mimic by clicking an empty area. When clearing object/drawing while moving the mouse on top of it, the color turns to red.
- C) Text tool.
- D) Different type of line tools. To move existing drawings/objects on mimic go on top of it and hold down mouse left and move around. When you are on top of drawing/object it changes the color to green.
- E) Different type of configurable objects. Number of the object corresponds to the number in OBJECT -menu.
- F) Some predefined drawings.

NOTE: To enable new drawings and changes in mimic press “Write changes to device” or “Write current view to device” button when using VAMPSET setting tool.

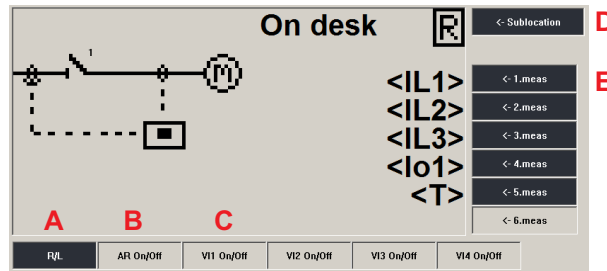

Figure 5.26: Mimic display can hold different type of information which is specified below. It is also possible to change status of certain items while local control is enabled.

A) Remote/Local selection defines whether certain actions are granted or not. In remote state it is not possible to locally enable/disable auto-reclosing or to control objects. Remote / Local state can be changed in objects -menu as well.

B) Creates auto-reclosing on/off selection to mimic.

C) Creates virtual input activation on local mimic display.

D) Describes the location of device. Text comes from device info menu.

E) Up to six user configurable measurements.

Table 5.10: Mimic functionality

Parameter	Value	Unit	Description	Set
Sublocation	Text field		Up to 9 characters. Fixed location.	Set
Object 1 – 8	1 – 8		Click on top of the object to change the control number between 1 and 8. Number 1 corresponds to object 1 in objects - menu.	Set
Local / Remote mode	L R		Local / Remote control. R stands for remote. Remote local state can be changed in objects -menu as well. Position can be changed.	Set
Auto-reclosure	0 1		Possible to enable/disable auto-reclosure locally in local mode (L) or remotely in remote mode (R). Position can be changed.	Set
Measurement display 1 – 6	IL1 – IL3, I0, U12, U23, U31, UL1, UL2, UL3, U0, f, P, Q, S, P.F., CosPhi, E+, Eq+, E-, Eq-, ARStart, ARFaill, ARShot1 – 5, IFLT, Starts, Trips, I0Calc, IL1 – IL3da, IL, Pda, Qda, Sda, T, fSYNC, USYNC, I'L1 – I'L3, dIL1 – dIL3		Up to 6 freely selectable measurements.	Set
Virtual input 1 – 4	0 1		Change the status of virtual inputs while the password is enabled. Position can be changed.	Set

Set = Settable.

5.7.2 Local panel configuration

Information displayed on the measurement view is configured in local panel configuration menu.

LOCAL PANEL CONFIGURATION

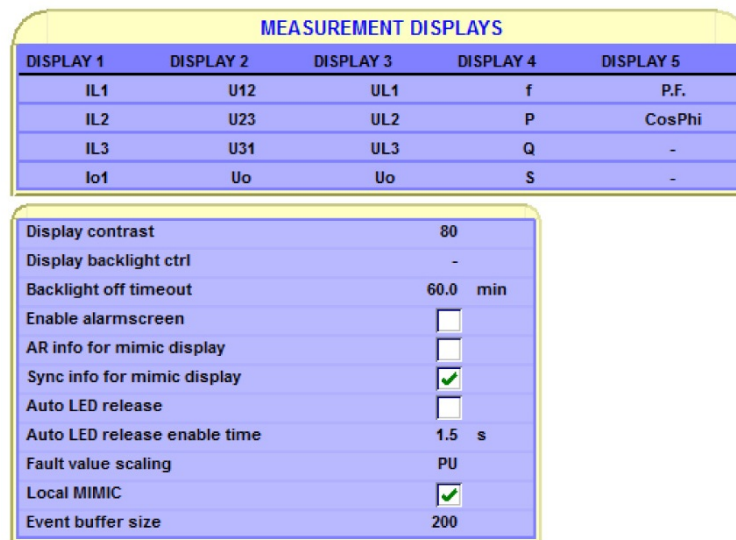

Figure 5.27: Local panel configuration menu

Table 5.11: Local panel configuration

Parameter	Value	Unit	Description	Set
Display 1 – 5	IL1 – 3, I0, U12, U23, U31, UL1, UL2, UL3, U0, f, P, Q, S, P.F., CosPhi, E+, Eq+, E-, Eq-, ARStart, ARFaill, ARShot1 – 5, IFLT, Starts, Trips, I0Calc, IL1-3da, IL, Pda, Qda, Sda, T, fSYNC, USYNC, I'L1 – 3, dIL1 – 3		20 (5 x 4) freely configurable measurement values can be selected	Set (*)
Display contrast	50 – 210		Contrast can be changed in the device menu as well.	Set
Display backlight control	DI1 – 44, Arc1 – 3, ArcF, BI, VI1 – 4, LED1 – 14, VO1 – 6		Activates the backlight of the display.	Set (*)
Backlight off timeout	0.0 – 2000.0	min	Configurable delay for backlight to turn off when the device is not used. Default value is 60 minutes. When value is zero (0.0) backlight stays on all the time.	Set
Enable alarm screen	Checked Unchecked		Pop-up text box for events. pop-up events can be checked individually by pressing enter, but holding the button for 2 seconds checks all the events at once.	Set
AR info for mimic display	Checked Unchecked		Auto reclosure status visible on top of the local mimic display.	Set

Parameter	Value	Unit	Description	Set
Sync I info for mimic display	Checked Unchecked		Synchro-check status visible on top of the local mimic display. Operates together with auto-reclosure.	Set
Auto LED release	Checked Unchecked		Enables automatix LED release functionality.	Set
Auto LED release enable time	0.1 – 600	s	Default 1.5 s. When new LED/LEDs is/are latched, previous active latches will be released automatically if the set time has passed.	Set
Fault value scaling	PU, Pri		Fault values per unit or primary sscaled.	Set
Local MIMIC	Checked Unchecked		Enable / disable the local mimic (enabled as default).	Set
Event buffer size	50 – 2000		Event buffer size. Default setting is 200 events.	Set

Set = Settable. (*) = Inputs vary according the device type.

5.7.3 Function buttons

VAMP 300G has two function buttons F1 & F2 and control buttons for breaker control. See picture below:



Figure 5.28: Function buttons F1 and F2 (1). Control buttons green and red (2)







There are two independent function keys, F1 and F2, available in the device front panel. As default, these keys are programmed to toggle VI1 and VI2. It is possible to change F1 & F2 to toggle other VI's or to act as object control.

VAMP 300G also has dedicated control buttons for object. Green (I) stands for object close and red (O) controls object open command internally. Control buttons are configured in OBJECTS view.



Table 5.12: Parameters of F1, F2

Parameter	Value	Unit	Description	Set
F1 – F2 VI1 – VI4	0		Function key toggles Virtual input 1 – 4 and Function button 1 – 2 between on (1) and off (0)	Set
ObjCtrl PrgFnCs	1		When Object control in chosen F1 and F2 can be linked in OBJECTS to desired objects close/open command.	

Control object (while at least operator level password is enabled and mode is selective)

1. Press  to close object.
 - Press  again to confirm
 - Press  to cancel
2. Press  to open object.
 - Press  again to confirm.
 - Press  to cancel

Control object (while least operator level password is enabled and mode is direct)

- Press  to close object.
- Press  to open object

NOTE: Password usage in breaker control can be disabled in OBJECTS setting.

6 Protection functions

6.1 Maximum number of protection stages in one application

The device limits the maximum number of enabled stages to about 30, depending of the type of the stages.

Table 6.1: List of protection functions

IEEE/ANSI code	IEC symbol	Function name
21	Z<, Z<<	Underimpedance protection
21/40	X<, X<<	Underreactance protection (Loss of excitation)
25	Δf , ΔU , $\Delta \varphi$	Synchrocheck
27	U<, U<<, U<<<	Undervoltage protection
27P	$U_{1<}$, $U_{1<<}$	Positive sequence undervoltage protection for generator applications
37	I<	Undercurrent protection
40	Q<	Underexcitation protection
46	$I_2>$	Current unbalance protection in motor mode *
46R	$I_2/I_1>$	Broken line protection
47	$I_2>>$	Phase reversal / incorrect phase sequence protection
49	T>	Thermal overload protection
50/51	I>, I>>, I>>>	Overcurrent protection
50BF	CBFP	Circuit-breaker failure protection
50N/51N	$I_0>$, $I_0>>$, $I_0>>>$, $I_0>>>>$	Earth fault protection
51V	$I_V>$	Voltage restrained or voltage controlled overcurrent function
59	U>, U>>, U>>>	Overvoltage protection
59N	$U_0>$, $U_0>>$	Zero sequence voltage protection
64F3	$U_{0r3<}$	100 % stator earth fault protection
67	$I_\varphi>$, $I_\varphi>>$, $I_\varphi>>>$, $I_\varphi>>>>$	Directional overcurrent protection
67N	$I_{0\varphi>}$, $I_{0\varphi>>}$	Directional earth-fault, low-set stage, sensitive, definite or inverse time (can be used as non directional)
68F2	$I_{r2>}$	Magnetising inrush
68F5	$I_{r5>}$	Transformer overexcitation
78		Pole slip protection
81H/81L	$f><$, $f><<$	Overfrequency and underfrequency protection
81L	$f<$, $f<<$	Underfrequency protection
81R	df/dt	Rate of change of frequency (ROCOF) protection
87	$\Delta I>$, $\Delta I>>$	Differential overcurrent protection

6.2 General features of protection stages

Setting groups

Setting groups are controlled by using digital inputs, function keys or virtual inputs. When none of the assigned input/inputs is/are not active the active setting group is defined by parameter 'SetGrp no control state'. When controlled input activates the corresponding setting group is activated as well. If multiple inputs are active at the same time the active setting group is defined by 'SetGrp priority'. By using virtual I/O the active setting group can be controlled using the local panel display, any communication protocol or using the inbuilt programmable logic functions.

Set group 1 DI control	-			
Set group 2 DI control	-			
Set group 3 DI control	-			
Set group 4 DI control	-			
Group	1			
	Group 1	Group 2	Group 3	Group 4
Pick-up setting	480 A	480 A	480 A	480 A
Pick-up setting	1.20 xlmot	1.20 xlmot	1.20 xlmot	1.20 xlmot
Delay curve family	IEC	IEC	IEC	IEC
Delay type	NI	NI	NI	NI
Inv. time coefficient k	1.00	1.00	1.00	1.00
Inverse delay (20x)	2.26 s	2.26 s	2.26 s	2.26 s
Inverse delay (4x)	4.97 s	4.97 s	4.97 s	4.97 s
Inverse delay (1x)	600.02 s	600.02 s	600.02 s	600.02 s
Common settings				
Include harmonics	Off			

Example

Any digital input could be used to control setting groups but in this example DI1, DI2, DI3 and DI4 are chosen to control setting groups 1 to 4. This setting is done with a parameter "Set group x DI control" where x refers to the desired setting group.

Set group 1 DI control	DI1			
Set group 2 DI control	DI2			
Set group 3 DI control	DI3			
Set group 4 DI control	DI4			
Group	2			
	Group 1	Group 2	Group 3	Group 4
Pick-up setting	1500 A	3600 A	3600 A	3600 A
Pick-up setting	0.50 xln	1.20 xln	1.20 xln	1.20 xln
Delay curve family	DT	IEC	IEC	IEC
Delay type	DT	NI	NI	NI
Operation delay	0.30 s	0.30 s	0.30 s	0.30 s
Inv. time coefficient k	1.00	1.00	1.00	1.00
Inverse delay (20x)	- s	2.26 s	2.26 s	2.26 s
Inverse delay (4x)	- s	4.97 s	4.97 s	4.97 s
Inverse delay (1x)	- s	600.02 s	600.02 s	600.02 s

Figure 6.1: DI1, DI2, DI3, DI4 are configured to control Groups 1 to 4 respectively.

"SetGrp priority" is used to give a condition to a situation where two or more digital inputs, controlling setting groups, are active and at a same time. SetGrp priority could have values "1 to 4" or "4 to 1".

VALID PROTECTION STAGES	
Enabled stages	1
SetGrp common change	1
SetGrp no control state	1
SetGrp priority	1 to 4

Figure 6.2: SetGrp priority setting is located in the Valid Protection stages view.

Assuming that DI2 and DI3 are active at a same time and SetGrp priority is set to “1 to 4” setting group 2 will become active. In case SetGrp priority is reversed i.e. it is set to “4 to 1” setting group 3 would be active.

Forcing start or trip condition for testing

The status of a protection stage can be one of the followings:

- **Ok = ‘-‘**
The stage is idle and is measuring the analog quantity for the protection. No fault detected.
- **Blocked**
The stage is detecting a fault but blocked by some reason.
- **Start**
The stage is counting the operation delay.
- **Trip**
The stage has tripped and the fault is still on.

Forcing start or trip condition for testing purposes

After testing the force flag will automatically reset 5-minute after the last local panel push button activity.

Force flag can be found in relays menu.

RELAYS	
Trip relay 1	0
Trip relay 2	0
Trip relay 3	0
Trip relay 4	0
Signal relay 1	0
Service status output	0
Enable forcing	On

Start and trip signals

Every protection stage has two internal binary output signals: start and trip. The start signal is issued when a fault has been detected.

The trip signal is issued after the configured operation delay unless the fault disappears before the end of the delay time.

Output matrix

Using the output matrix the user connects the internal start and trip signals to the output relays and indicators. For more details, see Chapter 5.4.1 Output matrix.

Blocking

Any protection function, except arc protection, can be blocked with internal and external signals using the block matrix (Chapter 5.4.2 Blocking matrix). Internal signals are for example logic outputs and start and trip signals from other stages and external signals are for example digital and virtual inputs.

When a protection stage is blocked, it won't pick-up in case of a fault condition is detected. If blocking is activated during the operation delay, the delay counting is frozen until the blocking goes off or the pick-up reason, i.e. the fault condition, disappears. If the stage is already tripping, the blocking has no effect.

Retardation time

Retardation time is the time a protection relay needs to notice that a fault has been cleared during the operate time delay. This parameter is important when grading the operate time delay settings between relays.

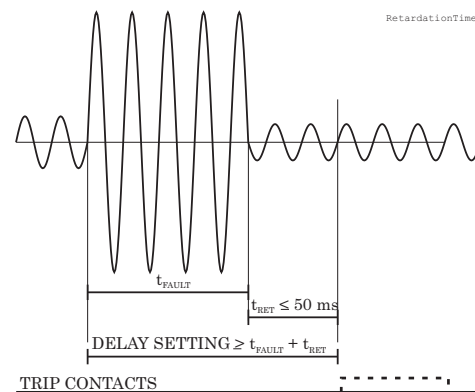

Figure 6.3: Definition for retardation time. If the delay setting would be slightly shorter, an unselective trip might occur (the dash line pulse).

For example, when there is a big fault in an outgoing feeder, it might start i.e. pick-up both the incoming and outgoing feeder relay. However, the fault must be cleared by the outgoing feeder relay and the incoming feeder relay must not trip. Although the operating delay setting of the incoming feeder is more than at the outgoing feeder, the incoming feeder might still trip if the operate time difference is not big enough. The difference must be more than the retardation

time of the incoming feeder relay plus the operate time of the outgoing feeder circuit breaker.

Figure 6.3 shows an overvoltage fault seen by the incoming feeder, when the outgoing feeder does clear the fault. If the operation delay setting would be slightly shorter or if the fault duration would be slightly longer than in the figure, an unselective trip might happen (the dashed 40 ms pulse in the figure). In VAMP devices the retardation time is less than 50 ms.

Reset time (release time)

Figure 6.4 shows an example of reset time i.e. release delay, when the relay is clearing an overcurrent fault. When the relay's trip contacts are closed the circuit breaker (CB) starts to open. After the CB contacts are open the fault current will still flow through an arc between the opened contacts. The current is finally cut off when the arc extinguishes at the next zero crossing of the current. This is the start moment of the reset delay. After the reset delay the trip contacts and start contact are opened unless latching is configured. The precise reset time depends on the fault size; after a big fault the reset time is longer. The reset time also depends on the specific protection stage.

The maximum reset time for each stage is specified in Chapter 11.3 Protection functions. For most stages it is less than 95 ms.

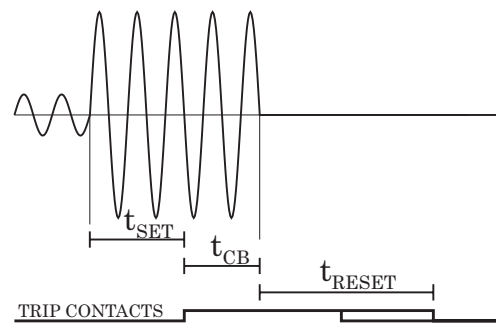

Figure 6.4: Reset time is the time it takes the trip or start relay contacts to open after the fault has been cleared.

Hysteresis or dead band

When comparing a measured value against a pick-up value, some amount of hysteresis is needed to avoid oscillation near equilibrium situation. With zero hysteresis any noise in the measured signal or any noise in the measurement itself would cause unwanted oscillation between fault-on and fault-off situations.

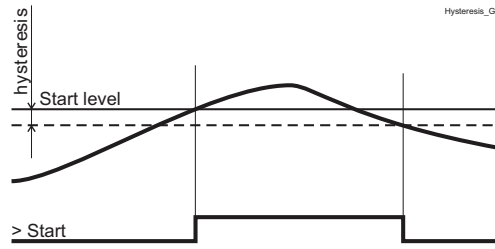

Figure 6.5: Behaviour of a greater than comparator. For example in overvoltage stages the hysteresis (dead band) acts according this figure.

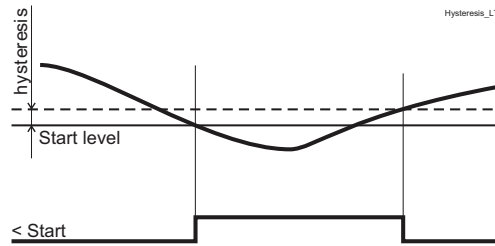

Figure 6.6: Behaviour of a less than comparator. For example in under-voltage and under frequency stages the hysteresis (dead band) acts according this figure.

6.3 Overcurrent protection I> (50/51)

Overcurrent protection is used against short circuit faults and heavy overloads.

The overcurrent function measures the fundamental frequency component of the phase currents. The protection is sensitive for the highest of the three phase currents. Whenever this value exceeds the user's pick-up setting of a particular stage, this stage picks up and a start signal is issued. If the fault situation remains on longer than the user's operation delay setting, a trip signal is issued.

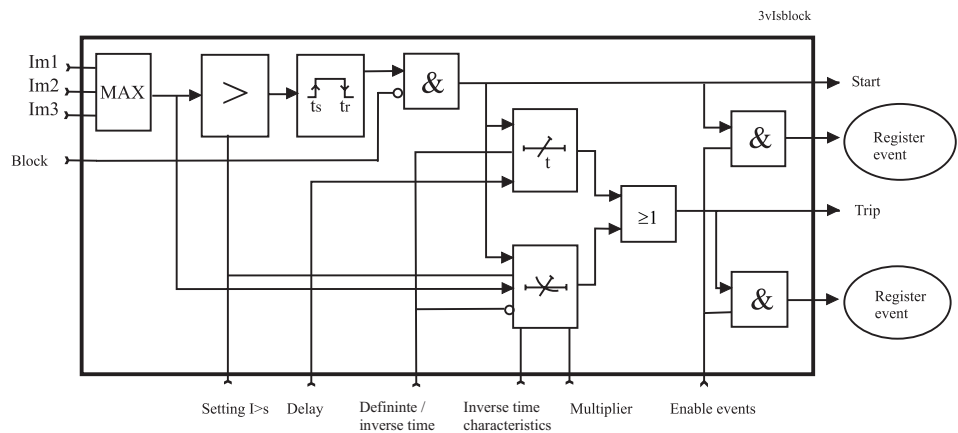

Figure 6.7: Block diagram of the three-phase overcurrent stage I>

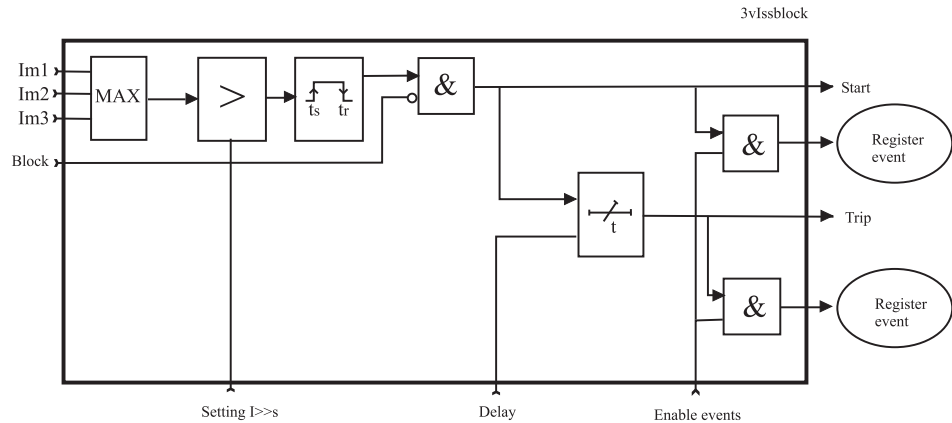

Figure 6.8: Block diagram of the three-phase overcurrent stage I>> and I>>>

Three independent stages

There are three separately adjustable overcurrent stages: I>, I>> and I>>>. The first stage I> can be configured for definite time (DT) or inverse time operation characteristic (IDMT). The stages I>> and I>>> have definite time operation characteristic. By using the definite delay type and setting the delay to its minimum, an instantaneous (ANSI 50) operation is obtained.

Figure 6.7 shows a functional block diagram of the I> overcurrent stage with definite time and inverse time operate time. Figure 6.8 shows a functional block diagram of the I>> and I>>> overcurrent stages with definite time operation delay.

Inverse operate time

Inverse delay means that the operate time depends on the amount the measured current exceeds the pick-up setting. The bigger the fault current is, the faster is the operation. Accomplished inverse delays are available for the I> stage. The inverse delay types are described in Chapter 6.31 Inverse time operation. The device shows the currently used inverse delay curve graph on the local panel display.

Inverse time limitation

The maximum measured secondary current is $50 \times I_N$. This limits the scope of inverse curves with high pick-up settings. See Chapter 6.31 Inverse time operation for more information.

Cold load and inrush current handling

See Chapter 6.29 Cold load pick-up and magnetising inrush.

Setting groups

There are four settings groups available for each stage. Switching between setting groups can be controlled by digital inputs, virtual

inputs (communication, logic) and manually. See Chapter 6.2 General features of protection stages for more details.

Table 6.2: Parameters of the overcurrent stage I> (50/51)

Parameter	Value	Unit	Description	Note
Status	- Blocked Start Trip		Current status of the stage	F F
TripTime		s	Estimated time to trip	
SCntr			Cumulative start counter	C
TCntr			Cumulative trip counter	C
SetGrp	1, 2, 3, 4		Active setting group	Set
SGrpDI			Digital signal to select the active setting group	Set
	-		None	
	Dlx		Digital input	
	Vlx		Virtual input	
	LEDx		LED indicator signal	
	VOx		Virtual output	
	Fx		Function key	
Force	Off On		Force flag for status forcing for test purposes. This is a common flag for all stages and output relays, too. This flag is automatically reset 5 minutes after the last front panel push button pressing.	Set
ILmax		A	The supervised value. Max. of IL1, IL2 and IL3	
Status			Current status of the stage	
I>		A	Pick-up value scaled to primary value	
I>		xI _{MODE}	Pick-up setting	Set
Curve	DT		Delay curve family: Definite time	Set
	IEC, IEEE, IEEE2, RI, PrgN		Inverse time. See Chapter 6.31 Inverse time operation.	
Type	DT		Delay type Definite time	Set
	NI, VI, EI, LTI, Parameters		Inverse time. See Chapter 6.31 Inverse time operation.	
t>		s	Definite operate time (for definite time only)	Set
k>			Inverse delay multiplier (for inverse time only)	Set
Dly20x		s	Delay at 20xImode	
Dly4x		s	Delay at 4xImode	
Dly2x		s	Delay at 2xImode	
Dly1x		s	Delay at 1xImode	
IncHarm		On/off	Include Harmonics	
Delay curves			Graphic delay curve picture (only local display)	

Parameter	Value	Unit	Description	Note
A, B, C, D, E			User's constants for standard equations. Type=Parameters. Chapter 6.31 Inverse time operation.	Set
Recorded values	LOG1		Date and time of trip	
	Type		Fault type	
	Flt	xI _{MODE}	Fault current	
	Load	xI _{MODE}	Pre-fault current	
	Edly	%	Elapsed delay time	
	SetGrp		Active set group during fault	

Set = An editable parameter (password needed). C = Can be cleared to zero. F = Editable when force flag is on.

For details of setting ranges, see Table 11.19

Table 6.3: Parameters of the overcurrent stages I>>, I>>> (50/51)

Parameter	Value	Unit	Description	Note
Status	-		Current status of the stage	
	Blocked			
	Start			F
	Trip			F
SCntr			Cumulative start counter	C
TCntr			Cumulative trip counter	C
SetGrp	1, 2, 3, 4		Active setting group	Set
SGrpDI			Digital signal to select the active setting group	Set
	-		None	
	DIx		Digital input	
	VIx		Virtual input	
	LEDx		LED indicator signal	
	VOx		Virtual output	
	Fx		Function key	
Force	Off		Force flag for status forcing for test purposes. This is a common flag for all stages and output relays, too. Automatically reset by a 5-minute timeout.	Set
	On			
ILmax		A	The supervised value. Max. of IL1, IL2 and IL3	
I>>, I>>>		A	Pick-up value scaled to primary value	
I>>, I>>>		xI _{MODE}	Pick-up setting	Set
t>>, t>>>		s	Definite operate time	Set
IncHarm		On/off	Include Harmonics	Set

Set = An editable parameter (password needed). C = Can be cleared to zero. F = Editable when force flag is on.

For details of setting ranges, see Table 11.20, Table 11.21.

Recorded values of the latest eight faults

There is detailed information available of the eight latest faults: Time stamp, fault type, fault current, load current before the fault, elapsed delay and setting group.

Table 6.4: Recorded values of the overcurrent stages (8 latest faults) I>, I>>, I>>> (50/51)

Parameter	Value	Unit	Description
	yyyy-mm-dd		Time stamp of the recording, date
	hh:mm:ss.ms		Time stamp, time of day
Type			Fault type
	1-N		Ground fault
	2-N		Ground fault
	3-N		Ground fault
	1-2		Two phase fault
	2-3		Two phase fault
	3-1		Two phase fault
	1-2-3		Three phase fault
Flt		xI_{MODE}	Maximum fault current
Load		xI_{MODE}	1 s average phase currents before the fault
EDly		%	Elapsed time of the operate time setting. 100% = trip
SetGrp	1, 2, 3, 4		Active setting group during fault

6.3.1 Remote controlled overcurrent scaling

Pick-up setting of the three over current stages can also be controlled remotely. In this case only two scaling coefficients are possible: 100% (the scaling is inactive) and any configured value between 10% - 200% (the scaling is active). When scaling is enabled all settings of group one are copied to group two but the pick-up value of group two is changed according the given value (10-200%).

- This feature can be enabled/disabled via VAMPSET or by using the local panel. When using VAMPSET the scaling can be activated and adjusted in the “protection stage status 2” –menu. When using the local panel similar settings can be found from the “prot” -menu.
- It is also possible to change the scaling factor remotely by using the modbus TCP –protocol. When changing the scaling factor remotely value of 1% is equal to 1. Check the correct modbus address for this application from the VAMPSET or from the communication parameter list.

The screenshot shows a control interface for 'Group 2 o/c remote scaling'. At the top, there is a status bar with 'Enable' and a green checkmark icon, and 'Grp. 2 remote scaling' with a value of '150 %'. Below this is a table comparing settings for Group 1 and Group 2. Red arrows point from the '150 %' value to the 'Pick-up setting' for Group 2 in the table, indicating that the Group 2 pick-up value is scaled by 150% from the Group 1 value.

Set group DI control		-	
Group		2	
	Group 1	Group 2	
Pick-up setting	1000 A	1500 A	
Pick-up setting	1.00 xIn	1.50 xIn	
Delay curve family	IEC	IEC	
Delay type	III	III	
Inv. time coefficient k	0.20	0.20	
Inverse delay (20x)	0.45 s	0.45 s	
Inverse delay (4x)	0.99 s	0.99 s	
Inverse delay (1x)	141.83 s	141.15 s	
Common settings			
Include harmonics	Off		

Figure 6.9: Remote scaling example.

In the Figure 6.9 can be seen the affect of remote scaling. After enabling group is changed from group one to group two and all settings from group one are copied to group two. The difference is that group two uses scaled pick-up settings.

NOTE: When remote scaling function is used, it replaces all the settings of group 2. So this function cannot be used simultaneously with normal group change.

6.4 Directional phase overcurrent $I_{\phi>}$ (67)

Directional overcurrent protection can be used for directional short circuit protection. Typical applications are:

- Short circuit protection of two parallel cables or overhead lines in a radial network.
- Short circuit protection of a looped network with single feeding point.
- Short circuit protection of a two-way feeder, which usually supplies loads but is used in special cases as an incoming feeder.
- Directional overcurrent protection in low impedance earthed networks. Please note that in this case the device has to be connected to line-to-neutral voltages instead of line-to-line voltages. In other words the voltage measurement mode has to be "3LN" (See chapter Chapter 4.9 Voltage measurement modes).

The stages are sensitive to the amplitude of the highest fundamental frequency current of the three measured phase currents.

In phase to phase and in three phase faults, the fault angle is determined by using angles between positive sequence of currents and voltages. In phase to ground faults, the fault angle is determined by using fault phase current and the healthy line to line voltage. For details of power direction, see Chapter 4.10 Direction of power and current.

A typical characteristic is shown in Figure 6.10. The base angle setting is -30° . The stage will pick up, if the tip of the three phase current phasor gets into the grey area.

NOTE: If the maximum possible earth fault current is greater than the used most sensitive directional over current setting, the device has to be connected to the line-to-neutral voltages instead of line-to-line voltages in order to get the right direction for earth faults, too. (For networks having the maximum possible earth fault current less than the over current setting, use 67N, the directional earth fault stages.)

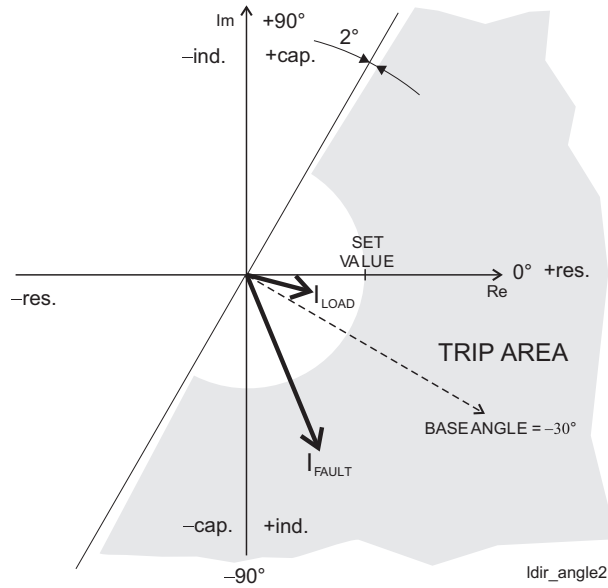

Figure 6.10: Example of protection area of the directional overcurrent function.

Three modes are available: dirctional, non-direct, and directional+back-up (Figure 6.11). In the non-directional mode the stage is acting just like an ordinary overcurrent 50/51 stage.

Directional+back-up mode works the same way as directional mode but it has undirectional back-up protection in case a close-up fault will force all voltages to about zero. After the angle memory hold time, the direction would be lost. Basically the directional+backup mode is required when operate time is set longer than voltage memory setting and no other undirectional back-up protection is in use.

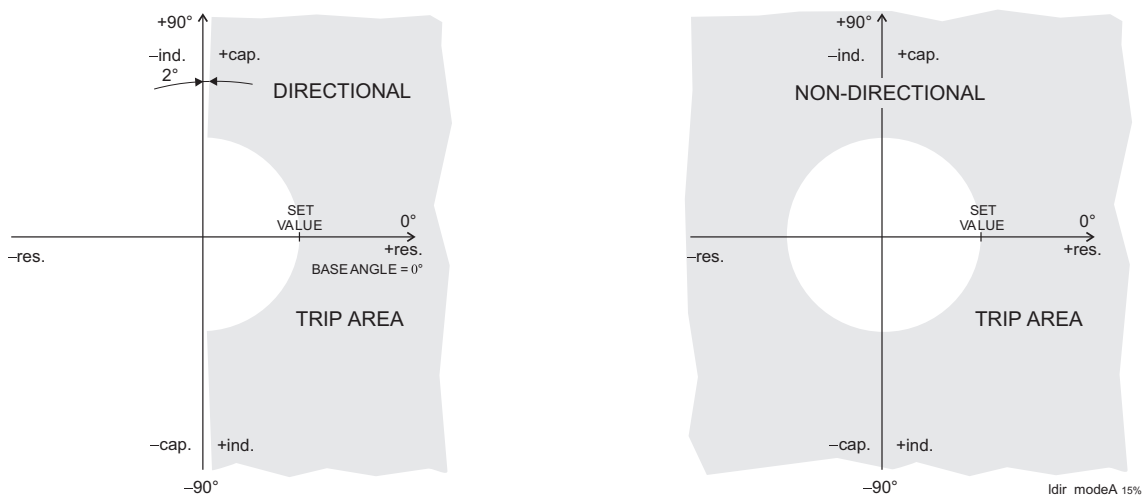

Figure 6.11: Difference between directional mode and non-directional mode. The grey area is the trip region.

An example of bi-directional operation characteristic is shown in Figure 6.12. The right side stage in this example is the stage $I_{\phi >}$ and

the left side is $I_{\phi>>}$. The base angle setting of the $I_{\phi>}$ is 0° and the base angle of $I_{\phi>>}$ is set to -180° .

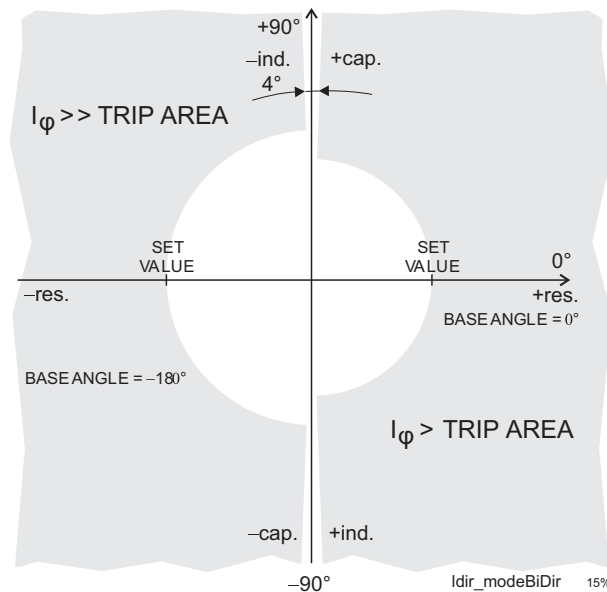

Figure 6.12: Bi-directional application with two stages $I_{\phi>}$ and $I_{\phi>>}$.

When any of the three phase currents exceeds the setting value and – in directional mode – the phase angle including the base angle is within the active $\pm 88^\circ$ wide sector, the stage picks up and issues a start signal. If this fault situation remains on longer than the delay setting, a trip signal is issued.

Four independent stages

There are four separately adjustable stages available: $I_{\phi>}$, $I_{\phi>>}$, $I_{\phi>>>}$ and $I_{\phi>>>>}$.

Inverse operate time

Stages $I_{\phi>}$ and $I_{\phi>>}$ can be configured for definite time or inverse time characteristic. See Chapter 6.31 Inverse time operation for details of the available inverse delays. Stages $I_{\phi>>>}$ and $I_{\phi>>>>}$ have definite time (DT) operation delay. The device will show a scaleable graph of the configured delay on the local panel display.

Inverse time limitation

The maximum measured secondary current is $50 \times I_N$. This limits the scope of inverse curves with high pick-up settings. See Chapter 6.31 Inverse time operation for more information.

Cold load and inrush current handling

See Chapter 6.29 Cold load pick-up and magnetising inrush

Setting groups

There are four settings groups available for each stage. Switching between setting groups can be controlled by digital inputs, virtual inputs (mimic display, communication, logic) and manually. See Chapter 6.2 General features of protection stages for more details.

Table 6.5: Parameters of the directional overcurrent stages $I_{\phi>}$, $I_{\phi>>}$ (67)

Parameter	Value	Unit	Description	Note
Status	- Blocked Start Trip		Current status of the stage	 F F
TripTime		s	Estimated time to trip	
SCntr			Cumulative start counter	C
TCntr			Cumulative trip counter	C
SetGrp	1, 2, 3, 4		Active setting group	Set
SGrpDI	- DIx VIx LEDx VOx Fx		Digital signal to select the active setting group None Digital input Virtual input LED indicator signal Virtual output Function key	Set
Force	Off On		Force flag for status forcing for test purposes. This is a common flag for all stages and output relays, too. Automatically reset by a 5-minute timeout.	Set
ILmax		A	The supervised value. Max. of IL1, IL2 and IL3	
$I_{\phi>}$, $I_{\phi>>}$		A	Pick-up value scaled to primary value	
$I_{\phi>}$, $I_{\phi>>}$		xI_{MODE}	Pick-up setting	Set
Curve	DT IEC, IEEE, IEEE2, RI, PrgN		Delay curve family: Definite time Inverse time. See Chapter 6.31 Inverse time operation.	Set
Type	DT NI, VI, EI, LTI, Parameters		Delay type Definite time Inverse time. See Chapter 6.31 Inverse time operation.	Set
$t_{>}$		s	Definite operate time (for definite time only)	Set
$k_{>}$			Inverse delay multiplier (for inverse time only)	Set
Dly20x		s	Delay at 20xImode	
Dly4x		s	Delay at 4xImode	
Dly2x		s	Delay at 2xImode	
Dly1x		s	Delay at 1xImode	

Parameter	Value	Unit	Description	Note
Mode	Dir		Directional mode (67)	Set
	Undir		Undirectional (50/51)	
	Dir+back-up		Directional and undirectional back-up	
Offset		°	Angle offset in degrees	Set
U/I angle		°	Measured U_1/I_1 angle	
U1		% U_N	Measured positive sequence voltage	
A, B, C, D, E			User's constants for standard equations. Type=Parameters. See Chapter 6.31 Inverse time operation.	Set

Set = An editable parameter (password needed). C = Can be cleared to zero. F = Editable when force flag is on.

For details of setting ranges, see Table 11.27

Table 6.6: Parameters of the directional overcurrent stages $I_{\phi}>>>$, $I_{\phi}>>>>$ (67)

Parameter	Value	Unit	Description	Note
Status	-		Current status of the stage	
	Blocked			
	Start			F
	Trip			F
SCntr			Cumulative start counter	C
TCntr			Cumulative trip counter	C
SetGrp	1, 2, 3, 4		Active setting group	Set
SGrpDI			Digital signal to select the active setting group	Set
	-		None	
	Dix		Digital input	
	Vix		Virtual input	
	LEDx		LED indicator signal	
	Vox		Virtual output	
	Fx		Function key	
Force	Off		Force flag for status forcing for test purposes. This is a common flag for all stages and output relays, too. Automatically reset by a 5-minute timeout.	Set
	On			
ILmax		A	The supervised value. Max. of IL1, IL2 and IL3	
$I_{\phi}>>>$, $I_{\phi}>>>>$		A	Pick-up value scaled to primary value	
$I_{\phi}>>>$, $I_{\phi}>>>>$		$\times I_{MODE}$	Pick-up setting	Set
$t>>>$		s	Definite operate time (for definite time only)	Set
$t>>>>$				
Mode	Dir		Directional (67)	Set
	Undir		Undirectional (50/51)	
	Dir+back-up		Directional and undirectional back-up	
Offset		°	Angle offset in degrees	Set
U/I angle		°	Measured U_1/I_1 angle	
U1		% U_N	Measured positive sequence voltage	

Set = An editable parameter (password needed). C = Can be cleared to zero. F = Editable when force flag is on.

For details of setting ranges, see Table 11.28

Recorded values of the latest eight faults

There are detailed information available of the eight latest faults: Time stamp, fault type, fault current, load current before the fault, elapsed delay and setting group.

Table 6.7: Recorded values of the directional overcurrent stages (8 latest faults) $I_{\phi>}$, $I_{\phi>>}$, $I_{\phi>>>}$, $I_{\phi>>>>}$ (67)

Parameter	Value	Unit	Description
	yyyy-mm-dd		Time stamp of the recording, date
	hh:mm:ss.ms		Time stamp, time of day
Type			Fault type
	1-N		Ground fault
	2-N		Ground fault
	3-N		Ground fault
	1-2		Two phase fault
	2-3		Two phase fault
	3-1		Two phase fault
	1-2-3		Three phase fault
	1-2-N		Two phase fault with earth contact
	2-3-N		Two phase fault with earth contact
	3-1-N		Two phase fault with earth contact
	1-2-3-N		Three phase fault with earth contact
Flt		xI_N	Maximum fault current
Load		xI_N	1 s average phase currents before the fault
EDly		%	Elapsed time of the operate time setting. 100% = trip
Angle		°	Fault angle in degrees
U1		xU_N	Positive sequence voltage during fault
SetGrp	1, 2, 3, 4		Active setting group during fault
Direction mode			Dir, undir, dir+back-up

6.5 Voltage restrained/controlled phase overcurrent $I_V >$ (51V)

The voltage restrained overcurrent stage $I_V >$ is used for generator short-circuit protection in applications, where the static excitation system of the generator is fed only from the generator terminals.

In these applications the operation of the high set overcurrent function must be secured using a voltage restrained overcurrent function. At close-by short circuits the fault current rapidly decreases, thus jeopardizing the operation of the high set short circuit protection. The operation characteristic of a voltage restrained overcurrent function is shown in Figure 6.13. The under impedance protection (see Chapter 6.21 Underimpedance $Z <$ (21)) can be used for the same purpose.

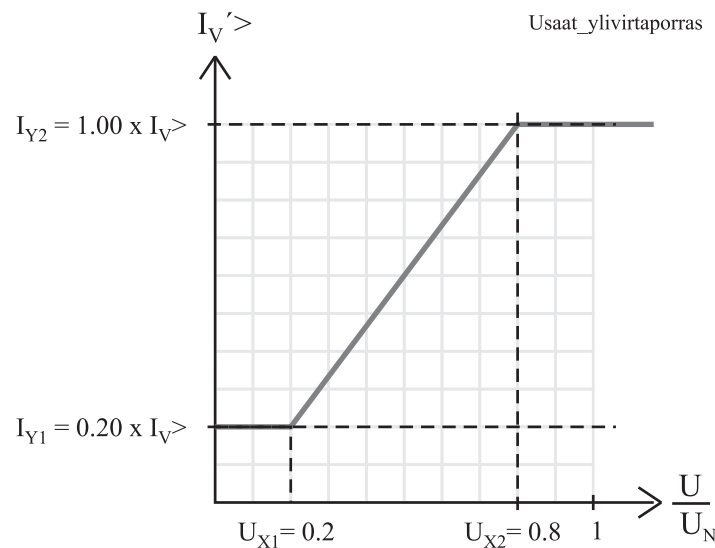

Figure 6.13: Characteristics of a voltage restrained overcurrent function $I_V >$.

When generator pole voltage falls below the set voltage level the pick-up current level of the overcurrent stage $I_V >$ also starts falling linearly controlled by the voltage according to the characteristic curve. See Figure 6.13.

When the setting parameters are selected according to Figure 6.14, the function is said to be voltage controlled.

NOTE: The overcurrent function can be used as a normal high-set overcurrent stage $I >>>$, if I_{Y1} and I_{Y2} are set to 100%.

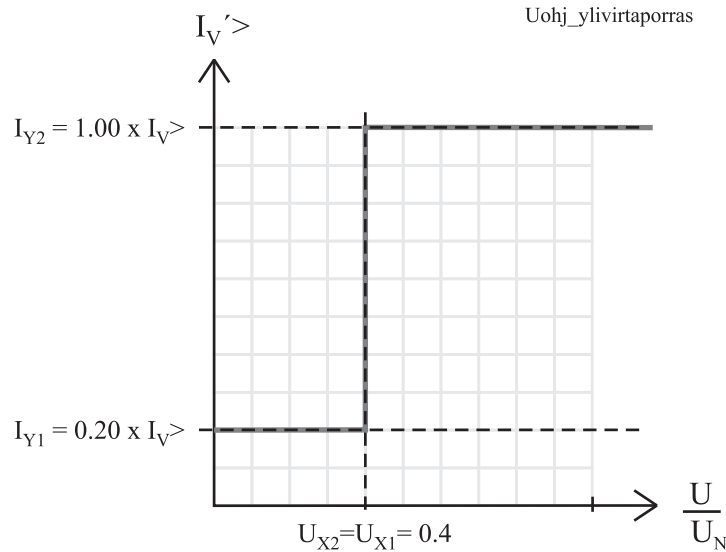

Figure 6.14: Voltage controlled overcurrent characteristics.

The voltage setting parameters U_{X1} and U_{X2} are proportional to the rated voltage of the generator. They define the voltage limits, within which the start current of the overcurrent unit is restrained. The multipliers I_{Y1} and I_{Y2} are used for setting the area of change of the start level of the overcurrent function in proportion to the U_{X1} and U_{X2} settings.

The voltage restrained/controlled overcurrent stage operates with definite time characteristic. The start current $I_V >$ and the operate time $t >$ can be set by the user.

Cold load and inrush current handling

See chapter Chapter 6.29 Cold load pick-up and magnetising inrush

Setting groups

There are four settings groups available. Switching between setting groups can be controlled by digital inputs, virtual inputs (mimic display, communication, logic) and manually.

Table 6.8: Parameters of the voltage restrained and voltage-controlled overcurrent stage $I_V >$ (51V)

Parameter	Value	Unit	Description	Note
Status	- Blocked Start Trip		Current status of the stage	 F F
SCntr			Cumulative start counter	C
TCntr			Cumulative trip counter	C
SetGrp	1, 2, 3, 4		Active setting group	Set

Parameter	Value	Unit	Description	Note
SGrpDI	- DIx VIx LEDx VOx		Digital signal to select the active setting group None Digital input Virtual input LED indicator signal Virtual output	Set
Force	Off On		Force flag for status forcing for test purposes. This is a common flag for all stages and output relays, too. Automatically reset by a 5-minute timeout.	Set
ILmax		A	The supervised value. Max. of IL1, IL2 and IL3	
Iv>		A	Pick-up value scaled to primary value	
Iv>		xI_{GN}	Pick-up setting	Set
t>		s	Definite operate time	Set
X1		%U1	Voltage for the 1st knee point. See Figure 6.10.	Set
X2		%U1	Voltage for the 2nd knee point	Set
Y1		%Iv>	Multiplier for pick-up setting at the 1st knee point	Set
Y2		%Iv>	Multiplier for pick-up setting at the 2nd knee point	Set

Set = An editable parameter (password needed). C = Can be cleared to zero. F = Editable when force flag is on.

For details of setting ranges, see Table 11.24

Recorded values of the latest eight faults

There are detailed information available of the eight latest faults: Time stamp, fault type, fault current, load current before the fault, elapsed delay and setting group.

Table 6.9: Recorded values of the voltage restrained/controlled overcurrent stages (8 latest faults) $I_V >$ (51V)

Parameter	Value	Unit	Description
	yyyy-mm-dd		Time stamp of the recording, date
	hh:mm:ss.ms		Time stamp, time of day
Type	1-N 2-N 3-N 1-2 2-3 3-1 1-2-3		Fault type Ground fault Ground fault Ground fault Two phase fault Two phase fault Two phase fault Three phase fault
Flt		xI_{GN}	Maximum fault current
Load		xI_{GN}	1 s average phase currents before the fault
EDly		%	Elapsed time of the operate time setting. 100% = trip

Parameter	Value	Unit	Description
SetGrp			Active setting group during the fault

6.6 Current unbalance protection $I_{2>}$, $I'_{2>}$ (46)

The current unbalance stage protects against unbalanced phase currents and single phasing. The protection is based on the negative sequence current. Both definite time and inverse time characteristics are available. The inverse delay is based on Equation 6.1. Only the base frequency components of the phase currents are used to calculate the negative sequence value I_2 .

The current unbalance protection is based on the negative sequence of the base frequency phase currents. Both definite time and inverse time characteristics are available.

Inverse delay

The inverse delay is based on the following equation.

Equation 6.1:

$$T = \frac{K_1}{\left(\frac{I_2}{I_{MOT}}\right)^2 - K_2^2}$$

T = Operate time

K_1 = Delay multiplier

I_2 = Measured and calculated negative sequence phase current of fundamental frequency.

I_{MOT} = Nominal current of the motor

K_2 = Pick-up setting $I_{2>}$ in pu. The maximum allowed degree of unbalance.

Example:

K_1 = 15 s

I_2 = 22.9 % = 0.229 x I_{MOT}

K_2 = 5 % = 0.05 x I_{MOT}

$$t = \frac{15}{\left(\frac{0.229}{1}\right)^2 - 0.05^2} = 300.4$$

The operate time in this example will be five minutes.

More stages (definite time delay only)

If more than one definite time delay stages are needed for current unbalance protection, the freely programmable stages can be used (Chapter 6.30 Programmable stages (99)).

Setting groups

There are four settings groups available. Switching between setting groups can be controlled by digital inputs, virtual inputs (communication, logic) and manually. See Chapter 6.2 General features of protection stages for more details.

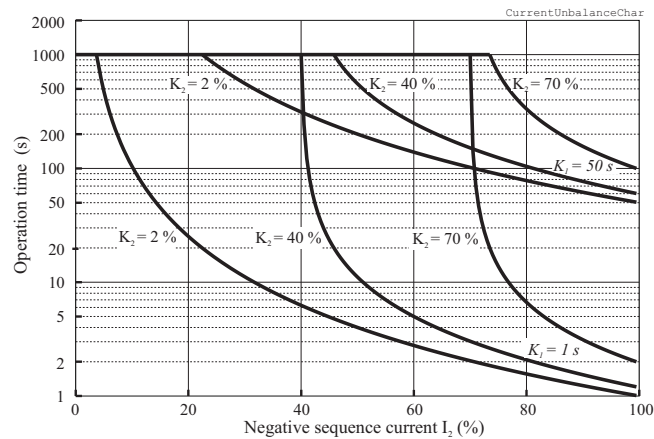

Figure 6.15: Inverse operation delay of current unbalance stage $I_2>$. The longest delay is limited to 1000 seconds (=16min 40s).

Table 6.10: Parameters of the current unbalance stage $I_2>$, $I_2'>$ (46)

Parameter	Value	Unit	Description	Note
Status	- Blocked Start Trip		Current status of the stage	 F F
SCntr			Cumulative start counter	C
TCntr			Cumulative trip counter	C
SetGrp	1, 2, 3, 4		Active setting group	Set
SGrpDI			Digital signal to select the active setting group	Set
	-		None	
	Dlx		Digital input	
	Vlx		Virtual input	
	LEDx		LED indicator signal	
	VOx		Virtual output	
	Fx		Function key	
Force	Off On		Force flag for status forcing for test purposes. This is a common flag for all stages and output relays, too. Automatically reset by a 5-minute timeout.	Set
I_2/In		$\%I_N$		
$I_2>$		$\%I_{MOT}$	Pick-up setting	Set
		$\%I_N$		
$t>$		s	Definite operate time (Type=DT)	Set

Parameter	Value	Unit	Description	Note
Type	DT		Definite time	Set
	INV		Inverse time (Equation 6.1)	
K1		s	Delay multiplier (Type =INV)	Set

Set = An editable parameter (password needed). C = Can be cleared to zero. F = Editable when force flag is on.

For details of setting ranges, see Table 11.23

Recorded values of the latest eight faults

There is detailed information available of the eight latest faults: Time stamp, unbalance current, elapsed delay and setting group.

Table 6.11: Recorded values of the current unbalance stage (8 latest faults) $I_2>$ (46)

Parameter	Value	Unit	Description
	yyyy-mm-dd		Time stamp of the recording, date
	hh:mm:ss.ms		Time stamp, time of day
Flt		% I_{GN}	Maximum unbalance current
EDly		%	Elapsed time of the operate time setting. 100% = trip
SetGrp	1, 2, 3, 4		Active setting group during the fault

6.7 Thermal overload protection T> (49)

The thermal overload function protects the motor in the motor mode or cables in the feeder mode against excessive heating.

Thermal model

The temperature is calculated using rms values of phase currents and a thermal model according IEC 60255-8. The rms values are calculated using harmonic components up to the 15th.

$$\text{Trip time: } t = \tau \cdot \ln \frac{I^2 - I_P^2}{I^2 - a^2}, \quad \tau \text{ unit: second}$$

$$\text{Alarm: } a = k \cdot k_{\Theta} \cdot I_{MODE} \cdot \sqrt{alarm} \quad (\text{Alarm 60\%} = 0.6)$$

$$\text{Trip: } a = k \cdot k_{\Theta} \cdot I_{MODE}$$

$$\text{Release time: } t = \tau \cdot C_{\tau} \cdot \ln \frac{I_P^2}{a^2 - I^2}, \quad \tau \text{ unit: second}$$

$$\text{Trip release: } a = \sqrt{0.95} \times k \times I_{MODE}$$

$$\text{Start release: } a = \sqrt{0.95} \times k \times I_{MODE} \times \sqrt{alarm} \quad (\text{Alarm 60\%} = 0.6)$$

T = operate time

τ = Thermal time constant tau (Setting value)

ln = Natural logarithm function

I = Measured rms phase current (the max. value of three phase currents)

I_p = Preload current, $I_P = \sqrt{\theta} \times k \times I_{MODE}$ (If temperature rise is 120% -> $\theta = 1.2$). This parameter is the memory of the algorithm and corresponds to the actual temperature rise.

k = Overload factor (Maximum continuous current), i.e. service factor.(Setting value)

k_Θ = Ambient temperature factor (Permitted current due to t_{amb}).

I_{MODE} = The rated current (I_N or I_{MOT})

C_τ = Relay cooling time constant (Setting value)

Time constant for cooling situation

If the motor's fan is stopped, the cooling will be slower than with an active fan. Therefore there is a coefficient C_T for thermal constant available to be used as cooling time constant, when current is less than $0.3 \times I_{MOT}$.

Heat capacitance, service factor and ambient temperature

The trip level is determined by the maximum allowed continuous current I_{MAX} corresponding to the 100 % temperature rise Θ_{TRIP} i.e. the heat capacitance of the motor or cable. I_{MAX} depends of the given service factor k and ambient temperature Θ_{AMB} and settings I_{MAX40} and I_{MAX70} according the following equation.

$$I_{MAX} = k \cdot k_{\Theta} \cdot I_{MODE}$$

The value of ambient temperature compensation factor k_{Θ} depends on the ambient temperature Θ_{AMB} and settings I_{MAX40} and I_{MAX70} . See Figure 6.16. Ambient temperature is not in use when $k_{\Theta} = 1$. This is true when

- I_{MAX40} is 1.0
- S_{amb} is "n/a" (no ambient temperature sensor)
- T_{AMB} is +40 °C.

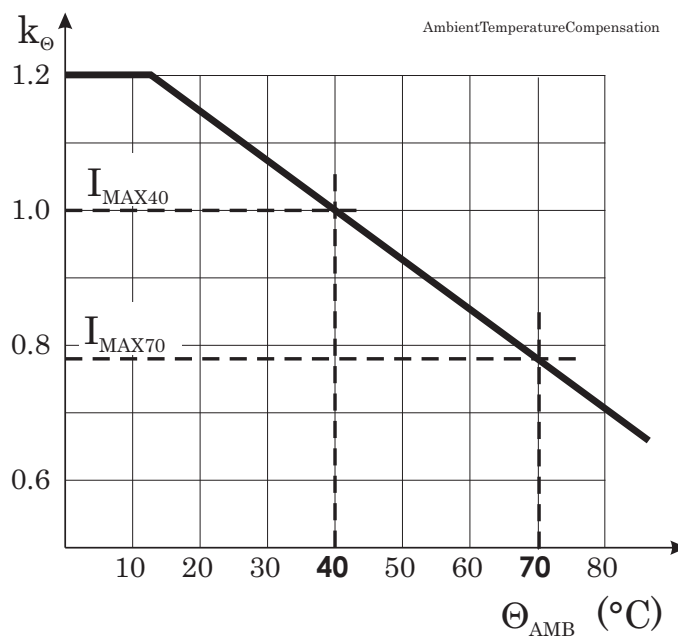

Figure 6.16: Ambient temperature correction of the overload stage T>.

Example of a behaviour of the thermal model

Figure 6.16 shows an example of the thermal model behaviour. In this example $\tau = 30$ minutes, $k = 1.06$ and $k\Theta = 1$ and the current has been zero for a long time and thus the initial temperature rise is 0 %. At time = 50 minutes the current changes to $0.85 \times xI_{MODE}$ and the temperature rise starts to approach value $(0.85/1.06)^2 = 64$ % according the time constant. At time = 300 min, the temperature is about stable, and the current increases to 5 % over the maximum defined by the rated current and the service factor k . The temperature rise starts to approach value 110 %. At about 340 minutes the temperature rise is 100 % and a trip follows.

Initial temperature rise after restart

When the device is switched on, an initial temperature rise of 70 % is used. Depending of the actual current, the calculated temperature rise then starts to approach the final value.

Alarm function

The thermal overload stage is provided with a separately settable alarm function. When the alarm limit is reached the stage activates its start signal.

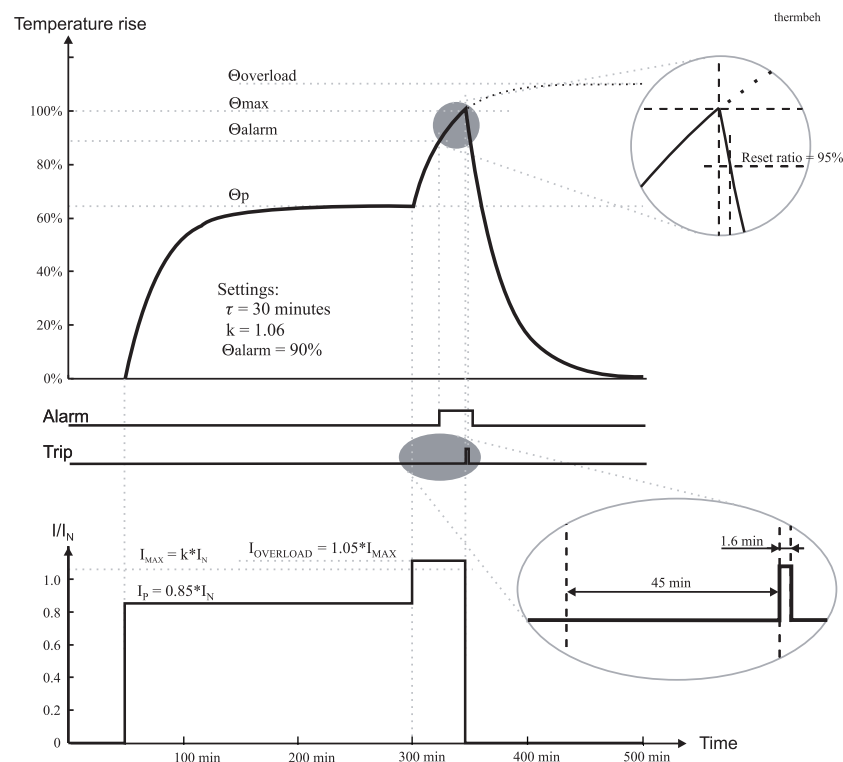

Figure 6.17: Example of the thermal model behaviour.

Table 6.12: Parameters of the thermal overload stage $T >$ (49)

Parameter	Value	Unit	Description	Note
Status	- Blocked Start Trip		Current status of the stage	 F F
Time	hh:mm:ss		Estimated time to trip	
SCntr			Cumulative start counter	C
TCntr			Cumulative trip counter	C
Force	Off On		Force flag for status forcing for test purposes. This is a common flag for all stages and output relays, too. Automatically reset by a 5-minute timeout.	Set
T		%	Calculated temperature rise. Trip limit is 100 %.	F
MaxRMS		Arms	Measured current. Highest of the three phases.	
I _{max}		A	$k \times I_{MODE}$. Current corresponding to the 100 % temperature rise.	
k _{>}		$\times I_{MODE}$	Allowed overload (service factor)	Set
Alarm		%	Alarm level	Set
tau		min	Thermal time constant	Set
ctau		xtau	Coefficient for cooling time constant. Default = 1.0	Set
kTamb		$\times I_{MODE}$	Ambient temperature corrected max. allowed continuous current	
I _{max40}		$\% I_{MODE}$	Allowed load at Tamb +40 °C. Default = 100 %.	Set
I _{max70}		$\% I_{MODE}$	Allowed load at Tamb +70 °C.	Set
Tamb		°C	Ambient temperature. Editable Samb=n/a. Default = +40 °C	Set
Samb			Sensor for ambient temperature	Set
	n/a		No sensor in use for Tamb	
	ExtAI1 – 16		External Analogue input 1 – 16	

Set = An editable parameter (password needed). C = Can be cleared to zero. F = Editable when force flag is on.

For details of setting ranges, see Table 11.22

6.8 Earth fault protection $I_0 >$ (50N/51N)

The unidirectional earth fault protection is to detect earth faults in low impedance earthed networks. In high impedance earthed networks, compensated networks and isolated networks unidirectional earth fault can be used as back-up protection.

The unidirectional earth fault function is sensitive to the fundamental frequency component of the residual current $3I_0$. The attenuation of the third harmonic is more than 60 dB. Whenever this fundamental value exceeds the user's pick-up setting of a particular stage, this stage picks up and a start signal is issued. If the fault situation

remains on longer than the user's operate time delay setting, a trip signal is issued.

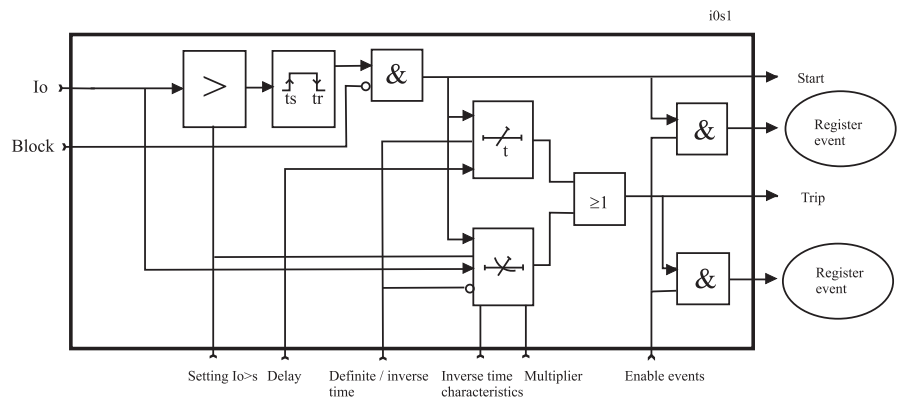

Figure 6.18: Block diagram of the earth fault stage $I_0 >$

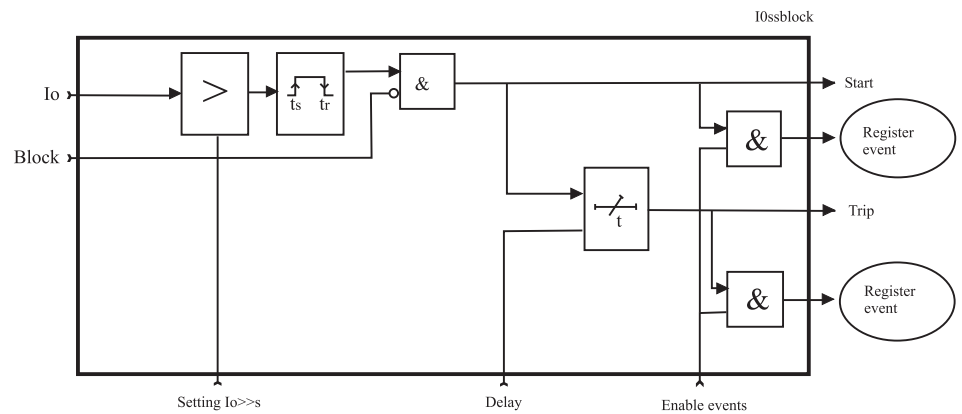

Figure 6.19: Block diagram of the earth fault stages $I_0 >>$, $I_0 >>>$, $I_0 >>>>$

Figure 6.18 shows a functional block diagram of the $I_0 >$ earth overcurrent stage with definite time and inverse time operate time. Figure 6.19 shows a functional block diagram of the $I_0 >>$, $I_0 >>>$ and $I_0 >>>>$ earth fault stages with definite time operation delay.

Input signal selection

Each stage can be connected to supervise any of the following inputs and signals:

- Input I_{01} for all networks other than rigidly earthed.
- Input I_{02} for all networks other than rigidly earthed.
- Calculated signal I_{0Calc} for rigidly and low impedance earthed networks. $I_{0Calc} = I_{L1} + I_{L2} + I_{L3}$.

Intermittent earth fault detection

Short earth faults make the protection to start (to pick up), but will not cause a trip. (Here a short fault means one cycle or more. For

shorter than 1 ms transient type of intermittent earth faults in compensated networks there is a dedicated stage $I_{0INT} >$ (67NI.) When starting happens often enough, such intermittent faults can be cleared using the intermittent time setting.

When a new start happens within the set intermittent time, the operation delay counter is not cleared between adjacent faults and finally the stage will trip.

Four or six independent unidirectional earth fault overcurrent stages

There are four separately adjustable earth fault stages: $I_0 >$, $I_0 >>$, $I_0 >>>$, and $I_0 >>>>$. The first stage $I_0 >$ can be configured for definite time (DT) or inverse time operation characteristic (IDMT). The other stages have definite time operation characteristic. By using the definite delay type and setting the delay to its minimum, an instantaneous (ANSI 50N) operation is obtained.

Using the directional earth fault stages (Chapter 6.9 Directional earth fault protection $I_{0\phi} >$ (67N)) in unidirectional mode, two more stages with inverse operate time delay are available for unidirectional earth fault protection.

Inverse operate time ($I_0 >$ stage only)

Inverse delay means that the operate time depends on the amount the measured current exceeds the pick-up setting. The bigger the fault current is the faster will be the operation. Accomplished inverse delays are available for the $I_0 >$ stage. The inverse delay types are described in Chapter 6.31 Inverse time operation. The device will show a scaleable graph of the configured delay on the local panel display.

Inverse time limitation

The maximum measured secondary residual current is $10 \times I_{0N}$ and maximum measured phase current is $50 \times I_N$. This limits the scope of inverse curves with high pick-up settings. See Chapter 6.31 Inverse time operation for more information.

Setting groups

There are four settings groups available for each stage. Switching between setting groups can be controlled by digital inputs, virtual inputs (communication, logic) and manually. See Chapter 6.2 General features of protection stages for more details.

Table 6.13: Parameters of the unidirectional earth fault stage $I_0 >$ (50N/51N)

Parameter	Value	Unit	Description	Note
Status	- Blocked Start Trip		Current status of the stage	F F
TripTime		s	Estimated time to trip	
SCntr			Cumulative start counter	Clr
TCntr			Cumulative trip counter	Clr
SetGrp	1, 2, 3, 4		Active setting group	Set
SGrpDI			Digital signal to select the active setting group	Set
	-		None	
	Dlx		Digital input	
	Vlx		Virtual input	
	LEDx		LED indicator signal	
	VOx		Virtual output	
	Fx		Function key	
Force	Off On		Force flag for status forcing for test purposes. This is a common flag for all stages and output relays, too. Automatically reset by a 5-minute timeout.	Set
Io, IoCalc, IoPeak		pu	The supervised value according the parameter "Input" below.	
Io>		A	Pick-up value scaled to primary value	
Io>		pu	Pick-up setting relative to the parameter "Input" and the corresponding CT value	Set
Curve	DT		Delay curve family: Definite time	Set
	IEC, IEEE, IEEE2, RI, PrgN		Inverse time. Chapter 6.31 Inverse time operation.	
Type	DT		Delay type. Definite time	Set
	NI, VI, EI, LTI, Parameters		Inverse time. Chapter 6.31 Inverse time operation.	
t>		s	Definite operate time (for definite time only)	Set
k>			Inverse delay multiplier (for inverse time only)	Set

Parameter	Value	Unit	Description	Note
Input	Io1		I_{01} (input 8/A/1:7 – 8 or 8/A/1:7 – 9) I_{01} (input 8/B/1:7 – 8 or 8/B/1:7 – 9) I_{01} (input 8/C/1:7 – 8) I_{01} (input 8/D/1:7 – 8) See .	Set
	Io2		I_{02} (input 8/C/1:9 – 10) I_{02} (input 8/D/1:9 – 10) See .	
	IoCalc		IL1 + IL2 + IL3	
Intrmt		s	Intermittent time	Set
Dly20x		s	Delay at 20 x I_{0N}	
Dly4x		s	Delay at 4 x I_{0N}	
Dly2x		s	Delay at 2 x I_{0N}	
Dly1x			Delay at 1 x I_{0N}	
A, B, C, D, E			User's constants for standard equations. Type=Parameters. See Chapter 6.31 Inverse time operation.	Set

Set = An editable parameter (password needed). C = Can be cleared to zero. F = Editable when force flag is on.

For details of setting ranges, see Table 11.25

Table 6.14: Parameters of the unidirectional earth fault stage $I_0 >>$, $I_0 >>>$, $I_0 >>>>$ (50N/51N)

Parameter	Value	Unit	Description	Note
Status	-		Current status of the stage	
	Blocked			
	Start			F
	Trip			F
TripTime		s	Estimated time to trip	
SCntr			Cumulative start counter	Clr
TCntr			Cumulative trip counter	Clr
SetGrp	1, 2, 3, 4		Active setting group	Set
SGrpDI			Digital signal to select the active setting group	Set
	-		None	
	Dix		Digital input	
	Vix		Virtual input	
	LEDx		LED indicator signal	
	VOx		Virtual output	
	Fx		Function key	
Force	Off		Force flag for status forcing for test purposes. This is a common flag for all stages and output relays, too. Automatically reset by a 5-minute timeout.	Set
	On			

Parameter	Value	Unit	Description	Note
I_0		pu	The supervised value according the parameter "Input" below.	
I_0Calc				
$I_0 >>$, $I_0 >>>$, $I_0 >>>>$		A	Pick-up value scaled to primary value	
$I_0 >>$, $I_0 >>>$, $I_0 >>>>$		pu	Pick-up setting relative to the parameter "Input" and the corresponding CT value	Set
$t >$		s	Definite operate time (for definite time only)	Set
Input	I_01		I_{01} (input 8/A/1:7 – 8 or 8/A/1:7 – 9) I_{01} (input 8/B/1:7 – 8 or 8/B/1:7 – 9) I_{01} (input 8/C/1:7 – 8) I_{01} (input 8/D/1:7 – 8) See .	Set
	I_02		I_{02} (input 8/C/1:9 – 10) I_{02} (input 8/D/1:9 – 10) See .	
	I_0Calc		$IL1 + IL2 + IL3$	

Set = An editable parameter (password needed). C = Can be cleared to zero. F = Editable when force flag is on.

For details of setting ranges, see Table 11.26

Recorded values of the latest eight faults

There is detailed information available of the eight latest earth faults: Time stamp, fault current, elapsed delay and setting group.

Table 6.15: Recorded values of the unidirectional earth fault stages (8 latest faults) $I_0 >>$, $I_0 >>>$, $I_0 >>>>$ (50N/51N)

Parameter	Value	Unit	Description
	yyyy-mm-dd		Time stamp of the recording, date
	hh:mm:ss.ms		Time stamp, time of day
Flt		pu	Maximum earth fault current
EDly		%	Elapsed time of the operate time setting. 100% = trip
SetGrp	1, 2, 3, 4		Active setting group during fault

6.8.1 Earth fault faulty phase detection algorithm

Phase recognition:

A zero sequence overcurrent has been detected.

Faulted phase/ phases are detected in 2 stage system.

1. Algorithm is using delta principle to detect the faulty phase/ phases.
2. Algorithm confirms the faulty phase with neutral current angle comparison to the suspected faulted phase.

Ideal grounded network:

When there is forward earth fault in phase L1, its current will increase creating calculated or measured zero sequence current in phase angle of 0 degrees. If there is reverse earth fault in phase L1, its current will decrease creating calculated or measured zero sequence current in phase angle of 180 degrees.

When there is forward earth fault in phase L2, its current will increase creating calculated or measured zero sequence current in phase angle of -120 degrees. If there is reverse earth fault in phase L2, its current will decrease creating calculated or measured zero sequence current in phase angle of 60 degrees.

When there is forward earth fault in phase L3, its current will increase creating calculated or measured zero sequence current in phase angle of 120 degrees. If there is reverse earth fault in phase L3 its current will decrease creating calculated or measured zero sequence current in phase angle of -60 degrees.

Implementation:

When faulty phase is recognized, it will be recorded in 50N protection fault log (also in event list and alarm screen). This faulted phase and direction recording function has a tick box for enabling/disabling in protection stage settings. For compensated network, this is not a 100% reliable algorithm because it depends on the network compensation degree. So for compensated networks this feature can be turned off so it will not cause confusion. For high impedance earthed networks, there will be drop down menu in both setting groups to choose between RES/CAP. RES is default and it is for earthed networks. When CAP is chosen, the I_0 angle will be corrected to inductive direction 90 degrees and after that faulty phase detection is made.

Possible outcomes and conditions for those detections:

- FWD L1
Phase L1 increases above the set limit and two other phases remain inside the set (delta) limit. I_0 current angle is +/- 60 degrees from L1 phase angle.

- **FDW L2**
Phase L2 increases above the set limit and two other phases remain inside the set (delta) limit. I_0 current angle is ± 60 degrees from L2 phase angle.
- **FDW L3**
Phase L3 increases above the set limit and two other phases remain inside the set (delta) limit. I_0 current angle is ± 60 degrees from L3 phase angle.
- **FWD L1-L2**
Phase L1 and L2 increase above the set limit and phase L3 remains inside the set (delta) limit. I_0 current angle is between L1 and L2 phase angles.
- **FWD L2-L3**
Phase L2 and L3 increase above the set limit and phase L1 remains inside the set (delta) limit. I_0 current angle is between L2 and L3 phase angles.
- **FWD L3-L1**
Phase L3 and L1 increase above the set limit and phase L2 remains inside the set (delta) limit. I_0 current angle is between L3 and L3 phase angles.
- **FWD L1-L2-L3**
All three phase currents increase above the set delta limit.
- **REV 1 (any one phase)**
One phase decreases below the set delta limit and other two phases remain inside the delta limit.
- **REV 2 (any two phase)**
Two phases decrease below the set delta limit and third phase remains inside the delta limit.
- **REV 3 (all three phases)**
All three phase currents decrease below the set delta limit.

Below are simulated different fault scenarios:

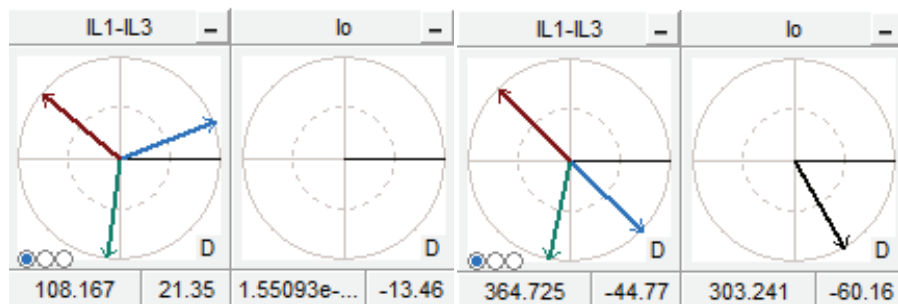

Figure 6.20: Phase L1 forward

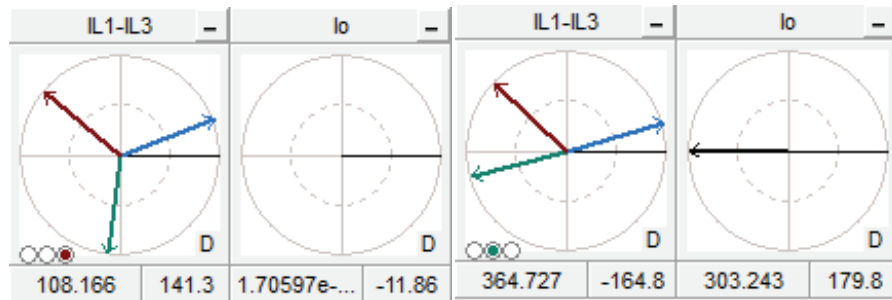

Figure 6.21: Phase L2 forward

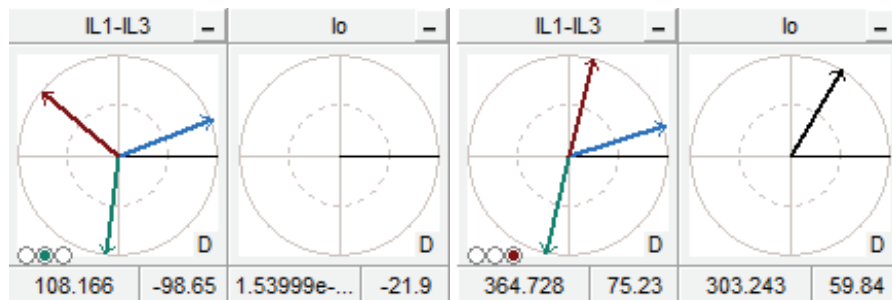

Figure 6.22: Phase L3 forward

6.9 Directional earth fault protection $I_{0\phi} > (67N)$

The directional earth fault protection is used in networks or motors where a selective and sensitive earth fault protection is needed and in applications with varying network structure and length.

The device consists of versatile protection functions for earth fault protection in various network types.

The function is sensitive to the fundamental frequency component of the residual current and zero sequence voltage and the phase angle between them. The attenuation of the third harmonic is more than 60 dB. Whenever the size of I_0 and U_0 and the phase angle between I_0 and U_0 fulfils the pick-up criteria, the stage picks up and a start signal is issued. If the fault situation remains on longer than the user's operate time delay setting, a trip signal is issued.

Polarization

The negative zero sequence voltage U_0 is used for polarization i.e. the angle reference for I_0 . The U_0 voltage is measured via energizing input U_0 or it is calculated from the phase voltages internally depending on the selected voltage measurement mode (see Chapter 4.9 Voltage measurement modes):

- 3LN: the zero sequence voltage is calculated from the phase voltages and therefore any separate zero sequence voltage transformers are not needed. The setting values are relative to the configured voltage transformer (VT) voltage/ $\sqrt{3}$.
- 3LN+ U_0 and 2LL+ U_0 : the zero sequence voltage is measured with voltage transformer(s) for example using a broken delta connection. The setting values are relative to the VT₀ secondary voltage defined in configuration.

Modes for different network types

The available modes are:

- ResCap

This mode consists of two sub modes, Res and Cap. A digital signal can be used to dynamically switch between these two sub modes. This feature can be used with compensated networks, when the Petersen coil is temporarily switched off.

 - Res

The stage is sensitive to the resistive component of the selected I_0 signal. This mode is used with compensated **networks** (resonant grounding) and **networks earthed with a high resistance**. Compensation is usually done with a Petersen coil between the neutral point of the main transformer and earth. In this context "high resistance" means, that the fault current is limited to be less than the rated phase current. The trip area is a half plane as drawn in Figure 6.24. The base angle is usually set to zero degrees.
 - Cap

The stage is sensitive to the capacitive component of the selected I_0 signal. This mode is used with **unearthed networks**. The trip area is a half plane as drawn in Figure 6.24. The base angle is usually set to zero degrees.
- Sector

This mode is used with **networks earthed with a small resistance**. In this context "small" means, that a fault current may be more than the rated phase currents. The trip area has a shape of a sector as drawn in Figure 6.25. The base angle is usually set to zero degrees or slightly on the lagging inductive side (i.e. negative angle).

- Undir
This mode makes the stage equal to the unidirectional stage $I_{0>}$. The phase angle and U_0 amplitude setting are discarded. Only the amplitude of the selected I_0 input is supervised.

Input signal selection

Each stage can be connected to supervise any of the following inputs and signals:

- Input I_{01} for all networks other than rigidly earthed.
- Input I_{02} for all networks other than rigidly earthed.
- Calculated signal I_{0Calc} for rigidly and low impedance earthed networks. $I_{0Calc} = I_{L1} + I_{L2} + I_{L3} = 3I_0$.

Intermittent earth fault detection

Short earth faults make the protection to start (to pick up), but will not cause a trip. (Here a short fault means one cycle or more. For shorter than 1 ms transient type of intermittent earth faults in compensated networks there is a dedicated stage $I_{0INT}>$ 67NI.) When starting happens often enough, such intermittent faults can be cleared using the intermittent time setting.

When a new start happens within the set intermittent time, the operation delay counter is not cleared between adjacent faults and finally the stage will trip.

Two independent stages

There are two separately adjustable stages: $I_{0\phi}>$ and $I_{0\phi}>>$. Both the stages can be configured for definite time delay (DT) or inverse time delay operate time.

Inverse operate time

Inverse delay means that the operate time depends on the amount the measured current exceeds the pick-up setting. The bigger the fault current is the faster will be the operation. Accomplished inverse delays are available for both stages $I_{0\phi}>$ and $I_{0\phi}>>$. The inverse delay types are described in Chapter 6.31 Inverse time operation. The device will show a scaleable graph of the configured delay on the local panel display.

Inverse time limitation

The maximum measured secondary residual current is $10 \times I_{0N}$ and maximum measured phase current is $50 \times I_N$. This limits the scope of inverse curves with high pick-up settings. See Chapter 6.31 Inverse time operation for more information.

Setting groups

There are four settings groups available for each stage. Switching between setting groups can be controlled by digital inputs, virtual inputs (communication, logic) and manually. See Chapter 6.2 General features of protection stages for more details.

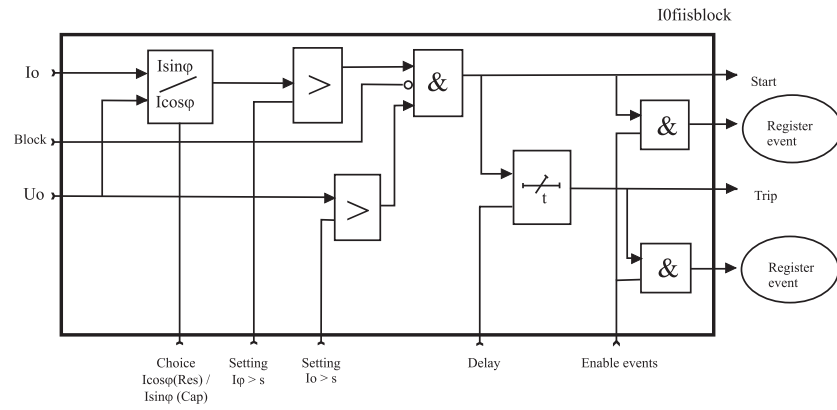

Figure 6.23: Block diagram of the directional earth fault stages $I_{0\varphi} >$, $I_{0\varphi} >>$

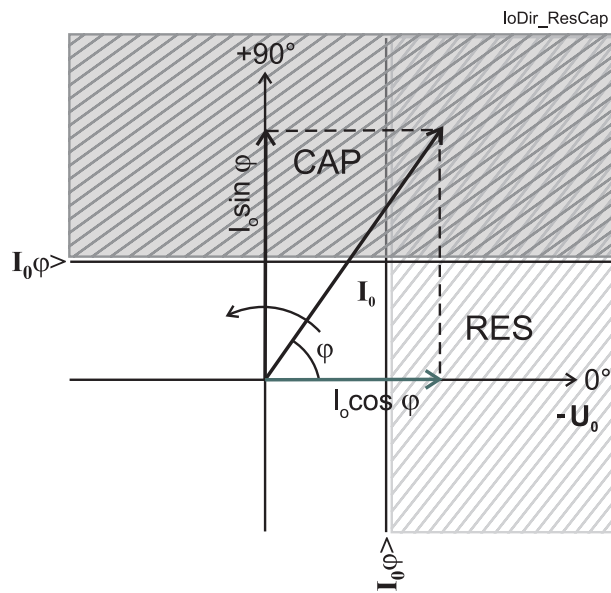

Figure 6.24: Operation characteristic of the directional earth fault protection in Res or Cap mode. Res mode can be used with compensated networks and Cap mode is used with ungrounded networks.

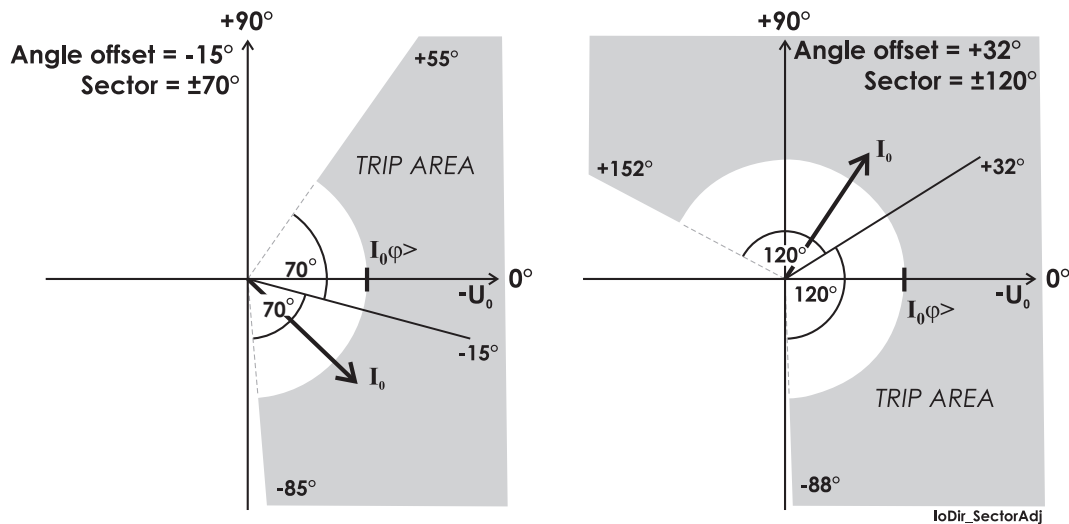

Figure 6.25: Two example of operation characteristics of the directional earth fault stages in sector mode. The drawn I_0 phasor in both figures is inside the trip area. The angle offset and half sector size are user's parameters.

Table 6.16: Parameters of the directional earth fault stages $I_{0\phi>}$, $I_{0\phi>>}$ (67N)

Parameter	Value	Unit	Description	Note
Status	- Blocked Start Trip		Current status of the stage	 F F
TripTime		s	Estimated time to trip	
SCntr			Cumulative start counter	Clr
TCntr			Cumulative trip counter	Clr
SetGrp	1, 2, 3, 4		Active setting group	Set
SGrpDI			Digital signal to select the active setting group	Set
	-		None	
	Dlx		Digital input	
	Vlx		Virtual input	
	LEDx		LED indicator signal	
	VOx		Virtual output	
	Fx		Function key	
Force	Off On		Force flag for status forcing for test purposes. This is a common flag for all stages and output relays, too. Automatically reset by a 5-minute timeout.	Set
Io IoCalc IoPeak		pu	The supervised value according the parameter "Input" below. ($I_{0\phi>}$ only)	
IoRes		pu	Resistive part of I_0 (only when "InUse"=Res)	
IoCap		pu	Capacitive part of I_0 (only when "InUse"=Cap)	
Io $\phi>$		A	Pick-up value scaled to primary value	

Parameter	Value	Unit	Description	Note
$I_{0\phi} >$		pu	Pick-up setting relative to the parameter "Input" and the corresponding CT value	Set
$U_0 >$		%	Pick-up setting for U_0	Set
U_0		%	Measured U_0	
Curve	DT IEC, IEEE, IEEE2, RI, PrgN		Delay curve family: Definite time Inverse time. Chapter 6.31 Inverse time operation.	Set
Type	DT NI, VI, EI, LTI, Parameters		Delay type. Definite time Inverse time. Chapter 6.31 Inverse time operation.	Set
$t >$		s	Definite operate time (for definite time only)	Set
$k >$			Inverse delay multiplier (for inverse time only)	Set
Mode	ResCap Sector Undir		High impedance earthed nets Low impedance earthed nets Undirectional mode	Set
Offset		°	Angle offset (MTA) for ResCap and Sector modes	Set
Sector	Default = 88	±°	Half sector size of the trip area on both sides of the offset angle	Set
ChCtrl			Res/Cap control in mode ResCap	Set
	Res		Fixed to Resistive characteristic	
	Cap		Fixed to Capacitive characteristic	
	Dlx		Controlled by digital input	
	Vlx		Controlled by virtual input	
InUse			Selected submode in mode ResCap.	
	-		Mode is not ResCap	
	Res		Submode = resistive	
	Cap		Submode = capacitive	
Input	Io1		I_{01} (input 8/A/1:7 – 8 or 8/A/1:7 – 9) I_{01} (input 8/B/1:7 – 8 or 8/B/1:7 – 9) I_{01} (input 8/C/1:7 – 8) I_{01} (input 8/D/1:7 – 8) See .	Set
	Io2		I_{02} (input 8/C/1:9 – 10) I_{02} (input 8/D/1:9 – 10) See .	
	IoCalc		IL1 + IL2 + IL3	
	Io1Peak		X1:7, 8, 9 peak mode ($I_{0\phi} >$ only)	
Intrmt		s	Intermittent time	Set
Dly20x		s	Delay at $20 \times I_{0N}$	

Parameter	Value	Unit	Description	Note
Dly4x		s	Delay at $4xI_{0N}$	
Dly2x		s	Delay at $2xI_{0N}$	
Dly1x		s	Delay at $1xI_{0N}$	
A, B, C, D, E			User's constants for standard equations. Type=Parameters. See Chapter 6.31 Inverse time operation.	Set

Set = An editable parameter (password needed). C = Can be cleared to zero. F = Editable when force flag is on.

For details of setting ranges, see Table 11.29

Recorded values of the latest eight faults

There is detailed information available of the eight latest earth faults: Time stamp, fault current, elapsed delay and setting group.

Table 6.17: Recorded values of the directional earth fault stages (8 latest faults) $I_{0\phi} >$, $I_{0\phi} >>$ (67N)

Parameter	Value	Unit	Description
	yyyy-mm-dd		Time stamp of the recording, date
	hh:mm:ss.ms		Time stamp, time of day
Flt		pu	Maximum earth fault current Resistive part of I_0 (only when "InUse"=Res) Capacitive part of I_0 (only when "InUse"=Cap)
EDly		%	Elapsed time of the operate time setting. 100% = trip
Angle	°		Fault angle of I_0 $-U_0 = 0^\circ$
Uo		%	Max. U_0 voltage during the fault
SetGrp	1, 2, 3, 4		Active setting group during fault

6.10 Switch On To Fault (50HS)

Switch On To Fault protection function offers fast protection when circuit breaker is closed manually against faulty line. Overcurrent based protection will not clear the fault until intended time delay has elapsed. SOTF will give trip signal without additional time delay if CB is closed and fault is detected after closing the breaker.

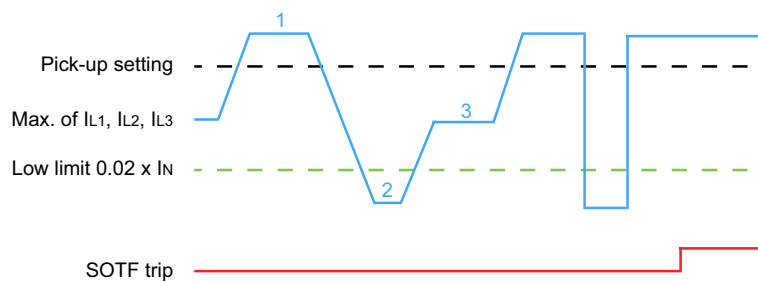

1. Switch on the fault will not activate if the breaker has not been in open position before fault. Open breaker detection will be noticed from the highest phase current value which has to be under a fixed low limit threshold ($0.02 \times I_N$). Opening of the breaker can be detected also with digital inputs (Dead line detection input = DI1 – DIx, V11 – V1x). The default detection input is based on the current threshold (Dead line detection input = “–”).
2. Dead line detection delay defines how long the breaker has to be open so that the SOTF function will be active. If the set time delay is not fulfilled and highest phase current value (maximum of I_{L1} , I_{L2} , I_{L3}) rises over pick-up setting SOTF will not operate.
3. If the highest phase current value of I_{L1} , I_{L2} , I_{L3} goes successfully under low limit and rises to a value between low limit and pick up set value then if highest phase current value rises over pick-up setting value before the set SOTF active after CB closure time delay has elapsed then SOTF will trip. If this time delay is exceeded SOTF will not trip even if the pick-up setting value is exceeded.

Table 6.18: Parameters of the Switch On To Fault stage SOTF (50HS)

Parameter	Value	Unit	Default	Description
Status	- Blocked Start Trip		-	Current status of the stage
TCntr			0	Cumulative trip counter
Pick-up setting		A		Pick-up value scaled to primary value
Pick-up setting		xI_N	$1.5 \times I_N$	Pick-up setting
Dead line detection delay		s	0.20 s	Dead line detection delay
SOTF active after CB closure		s	1.00s	SOTF active time after CB closure

Parameter	Value	Unit	Default	Description
Dead line detection input	-		-	Dead line detection input
	DI1 – DIx		(=a fixed low limit threshold (0.03 xIn)	
	VI1 – VIx			

For details of setting ranges, see Table 11.30

6.11 Differential overcurrent protection $\Delta I >$ (87)

The differential overcurrent protection comprises two separately adjustable stages, stage $\Delta I >$ and stage $\Delta I >>$.

The differential protection is based on winding currents difference between IL and I'L side. In Yy0 connection measured currents are also winding currents, see Figure 6.26. In pure generator applications the connection group is always Yy0. But should the generator have also block transformer, the connection group is dependent on both generator and transformer groups.

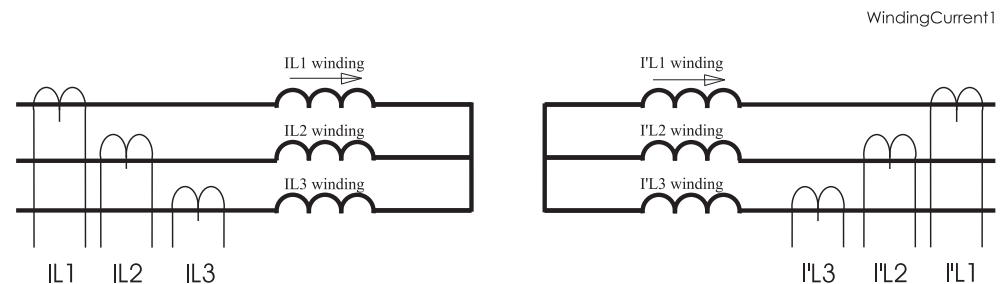

Figure 6.26: Winding currents in connection group Yy0.

In the second example if transformer IL side is connected to open delta, e.g. Dy11, then winding currents are calculated in delta side (IL side), see Figure 6.27.

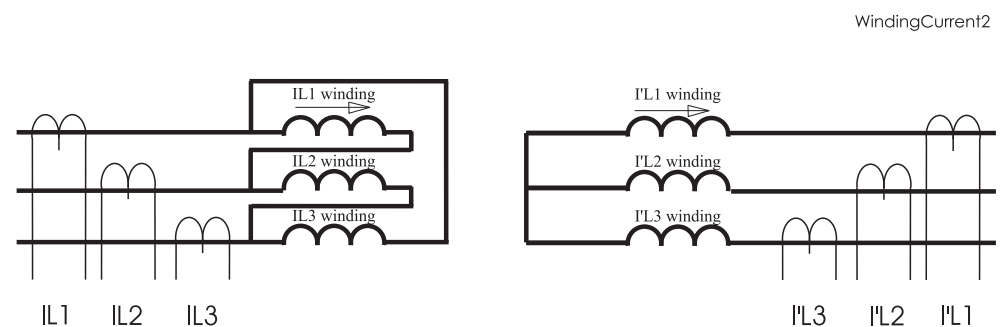

Figure 6.27: Winding currents in connection group Dy11.

Equation 6.2: Winding current calculation in delta side, Dy11 connection

$$\frac{\overline{I_{L1W}}}{\sqrt{3}} = \left(\overline{I_{L1}} - \overline{I_{L2}} \right)$$

$$\frac{\overline{I_{L2W}}}{\sqrt{3}} = \left(\overline{I_{L2}} - \overline{I_{L3}} \right)$$

$$\frac{\overline{I_{L3W}}}{\sqrt{3}} = \left(\overline{I_{L3}} - \overline{I_{L1}} \right)$$

Equation 6.3: Winding currents in star side, Dy11 connection

$$\overline{I'_{L1W}} = \overline{I'_{L1}}$$

$$\overline{I'_{L2W}} = \overline{I'_{L2}}$$

$$\overline{I'_{L3W}} = \overline{I'_{L3}}$$

Equation 6.4: Bias current

$$I_b = \frac{|\overline{I_W}| + |\overline{I'_{W}}|}{2}$$

Equation 6.5: Differential current

$$I_d = \left| \overline{I_W} + \overline{I'_{W}} \right|$$

Bias current calculation is only used in protection stage $\Delta I >$. Bias current describes the average current flow in transformer. Bias and differential currents are calculated individually for each phase.

If transformer is earthed, e.g. connection group Dyn11, then zero current must be compensated before differential and bias current calculation. Zero current compensation can be selected individually for IL and I'L side.

Table 6.19 describe connection group and zero current compensation for different connection groups. If protection area is only generator then connection group setting is always Yy0, see Table 6.20. Also the settings of Un and U'n are set to be the same, e.g. generator nominal voltage.

Table 6.19: Zero current compensation in transformer applications

Transformer Connection group	Relay setting		
	ConnGrp	Io cmps	I'o cmps
YNy0	Yy0	ON	OFF
YNyn0	Yy0	ON	ON
Yy0	Yy0	OFF	OFF
Yyn0	Yy0	OFF	ON
YNy6	Yy6	ON	OFF
YNyn6	Yy6	ON	ON
Yy6	Yy6	OFF	OFF
Yyn6	Yy6	OFF	ON
Yd1	Yd1	OFF	OFF
YNd1	Yd1	ON	OFF
Yd5	Yd5	OFF	OFF
YNd5	Yd5	ON	OFF
Yd7	Yd7	OFF	OFF
YNd7	Yd7	ON	OFF
Yd11	Yd11	OFF	OFF
YNd11	Yd11	ON	OFF
Dy1	Dy1	OFF	OFF
Dyn1	Dy1	OFF	ON
Dy5	Dy5	OFF	OFF
Dyn5	Dy5	OFF	ON
Dy7	Dy7	OFF	OFF
Dyn7	Dy7	OFF	ON
Dy11	Dy11	OFF	OFF
Dyn11	Dy11	OFF	ON

Table 6.20: Zero current compensation in generator applications

Generator only	Relay setting		
	ConnGrp	Io cmps	I'o cmps
None earthing	Yy0	OFF	OFF

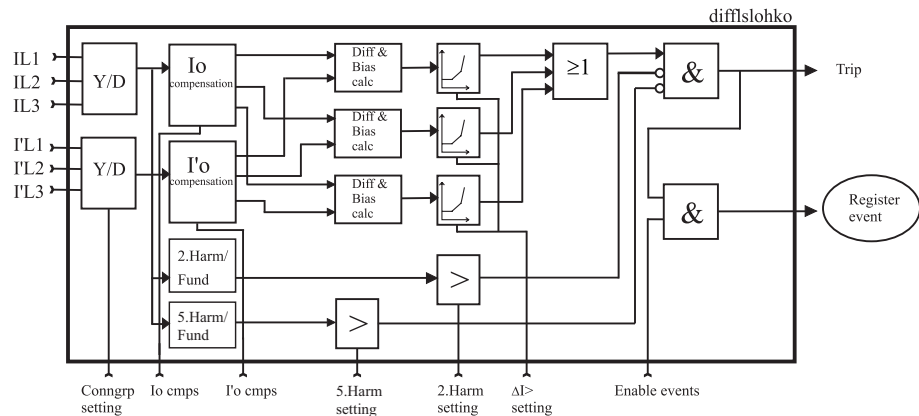

Figure 6.28: Block diagram of the differential overcurrent stage $\Delta I >$

The stage $\Delta I >$ can be configured to operate as shown in Figure 6.29. This dual slope characteristic allows more differential current at higher currents before tripping.

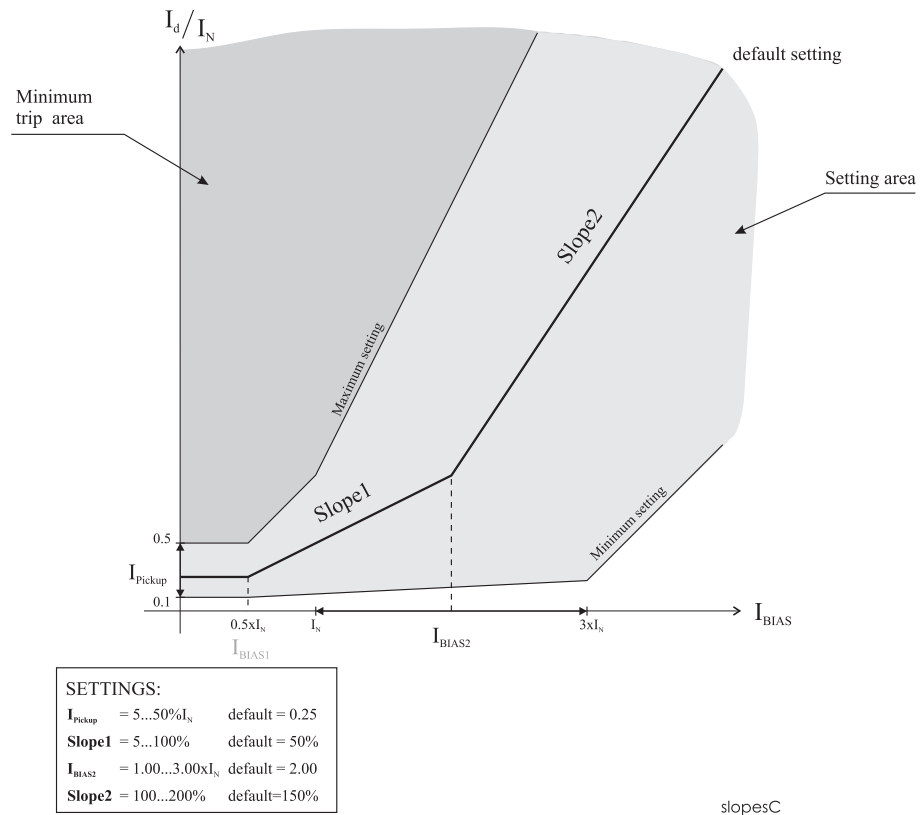

Figure 6.29: Example of differential overcurrent characteristics.

The stage also includes second harmonics blocking. The second harmonic is calculated from winding currents. Harmonic ratio is:

$$100 \times I_{f2_Winding} / I_{f1_Winding} [\%].$$

Fast differential overcurrent stage $\Delta I >>$ does not include slope characteristics and second harmonics blocking.

Table 6.21: Parameters of the differential overcurrent stages $\Delta I >$ (87)

	Parameter	Value/Unit	Description	
Measured values (1)	dIL1	xIn	Current difference value	
	dIL2			
	dIL3			
Setting values (2)	$\Delta I >$	%In	Setting value	
	Ibias1	xIn	Bias current start of slope 1	
	Slope1	%	Slope 1 setting	
	Ibias2	xIn	Bias current start of slope 2	
	Slope2	%	Slope 2 setting	
	Harm2>	On / Off	2. harmonic blocking enable/disable	
	Harm2>	%	2. harmonic block limit	
	TCntr		Cumulative trip counter	
	Type	1-N, 2-N, 3-N		Fault type/single-phase fault e.g.: 1 – N = fault on phase L1
		1-2, 2-3, 1-3		Fault type/two-phase fault e.g.: 2 – 3 = fault between L2 and L3
		1-2-3		Fault type/three-phase fault
Flt	xIn	Max. value of fault differential current as compared to I_N		
Load	xIn	1 s mean value of pre-fault phase currents IL1 – IL3		

1) Measurement ranges are described in Table 11.1.

2) Setting ranges are described in Table 11.17.

Table 6.22: Parameters of the differential overcurrent stages $\Delta I >>$ (87)

	Parameter	Value/Unit	Description
Measured values	dIL1	xIn	Current difference value
	dIL2		
	dIL3		
Setting values	$\Delta I >>$	xIn	Setting value
Recorded values	TCntr		Cumulative trip counter
Recorded values	Type	1-N, 2-N, 3-N	Fault type/single-phase fault e.g.: 1-N = fault on phase L1
		1-2, 2-3, 1-3	Fault type/two-phase fault e.g.: 2-3 = fault between L2 and L3
		1-2-3	Fault type/three-phase fault
	Flt	xIn	Max. value of fault differential current as compared to I_N
	Load	xIn	1 s mean value of pre-fault phase currents IL1 – IL3

1) Measurement ranges are described in Table 11.1.

2) Setting ranges are described in Table 11.18.

6.12 Overvoltage protection U> (59)

The overvoltage function measures the fundamental frequency component of the line-to-line voltages regardless of the voltage measurement mode (Chapter 4.9 Voltage measurement modes). By using line-to-line voltages any phase-to-ground over-voltages during earth faults have no effect. (The earth fault protection functions will take care of earth faults.) Whenever any of these three line-to-line voltages exceeds the user's pick-up setting of a particular stage, this stage picks up and a start signal is issued. If the fault situation remains on longer than the user's operate time delay setting, a trip signal is issued.

In rigidly earthed 4-wire networks with loads between phase and neutral overvoltage protection may be needed for phase-to-ground voltages, too. In such applications the programmable stages can be used. Chapter 6.30 Programmable stages (99)

Three independent stages

There are three separately adjustable stages: U>, U>> and U>>>. All the stages can be configured for definite time (DT) operation characteristic.

Configurable release delay

The U> stage has a settable release delay, which enables detecting intermittent faults. This means that the time counter of the protection function does not reset immediately after the fault is cleared, but resets after the release delay has elapsed. If the fault appears again before the release delay time has elapsed, the delay counter continues from the previous value. This means that the function will eventually trip if faults are occurring often enough.

Configurable hysteresis

The dead band is 3 % by default. It means that an overvoltage fault is regarded as a fault until the voltage drops below 97 % of the pick up setting. In a sensitive alarm application a smaller hysteresis is needed. For example if the pick up setting is about only 2 % above the normal voltage level, hysteresis must be less than 2 %. Otherwise the stage will not release after fault.

Setting groups

There are four settings groups available for each stage. Switching between setting groups can be controlled by digital inputs, virtual inputs (communication, logic) and manually. See Chapter 6.2 General features of protection stages for more details.

Figure 6.30 shows the functional block diagram of the overvoltage function stages U>, U>> and U>>>.

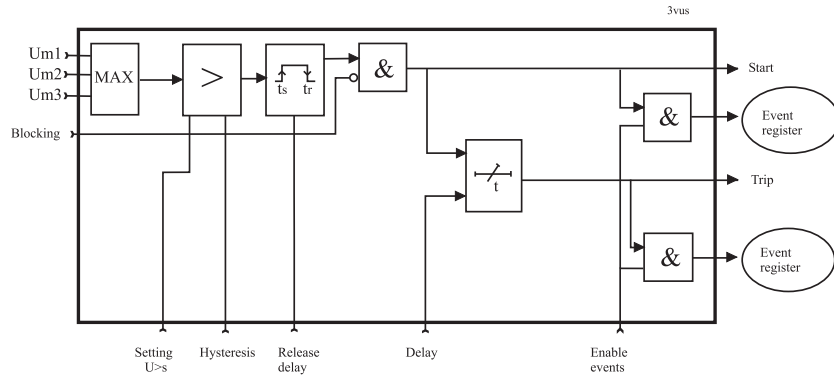

Figure 6.30: Block diagram of the three-phase overvoltage stages U>, U>> and U>>>

Table 6.23: Parameters of the overvoltage stages U>, U>>, U>>>

Parameter	Value	Unit	Description	Note	
Status	- Blocked Start Trip		Current status of the stage	 F F	
SCntr			Cumulative start counter	C	
TCntr			Cumulative trip counter	C	
SetGrp	1, 2, 3, 4		Active setting group	Set	
SGrpDI			Digital signal to select the active setting group	Set	
	-		None		
	Dlx		Digital input		
	Vlx		Virtual input		
	LEDx		LED indicator signal		
	VOx		Virtual output		
Force	Off On		Force flag for status forcing for test purposes. This is a common flag for all stages and output relays, too. Automatically reset by a 5-minute timeout.	Set	
	Umax		V	The supervised value. Max. of U12, U23 and U31	
U>, U>>, U>>>			V	Pick-up value scaled to primary value	
U>, U>>, U>>>			% Un	Pick-up setting relative to U_N	Set
t>, t>>, t>>>			s	Definite operate time	Set
RlsDly			s	Release delay (U> stage only)	Set
Hyster	3 (default)		%	Dead band size i.e. hysteresis	Set

Set = An editable parameter (password needed). C = Can be cleared to zero. F = Editable when force flag is on.

For details of setting ranges, see Table 11.31, Table 11.32, Table 11.33.

Recorded values of the latest eight faults

There are detailed information available of the eight latest faults: Time stamp, fault voltage, elapsed delay and setting group.

Table 6.24: Recorded values of the overvoltage stages (8 latest faults) $U >$, $U >>$, $U >>>$

Parameter	Value	Unit	Description
	yyyy-mm-dd		Time stamp of the recording, date
	hh:mm:ss.ms		Time stamp, time of day
Flt		% Un	Maximum fault voltage
EDly		%	Elapsed time of the operate time setting. 100% = trip
SetGrp	1, 2, 3, 4		Active setting group during fault

6.13 Volts/hertz over-excitation protection $U_f >$ (24)

The saturation of any inductive network components like transformers, inductors, motors and generators, depend on the voltage and frequency. The lower the frequency, the lower is the voltage at which the saturation begins.

The volts/hertz over-excitation protection stage is sensitive to the voltage/frequency ratio instead of voltage only. Figure 6.31 shows the difference between volts/hertz and a standard overvoltage function. The maximum of the three line-to-line voltage is used regardless of the voltage measurement mode (chapter Chapter 4.9 Voltage measurement modes). By using line-to-line voltages any phase-to-ground over-voltages during earth faults have no effect. (The earth fault protection functions will take care of earth faults.)

The used net frequency is automatically adopted according the local network frequency.

Overexcitation protection is needed for generators, which are excited even during start up and shut down. If such a generator is connected to a unit transformer, also the unit transformer needs volts/hertz over-excitation protection. Another application is sensitive overvoltage protection of modern transformers with no flux density margin in networks with unstable frequency.

Setting groups

There are four settings groups available for each stage. Switching between setting groups can be controlled by digital inputs, virtual inputs (communication, logic) and manually. See Chapter 6.2 General features of protection stages for more details.

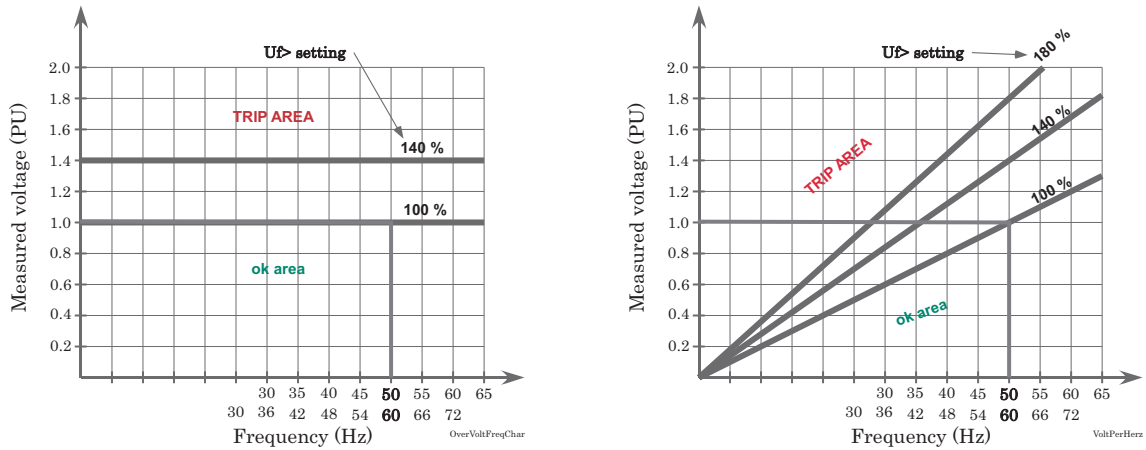

Figure 6.31: This figure shows the difference between volts/hertz and normal overvoltage protection. The volts/hertz characteristics on the left depend on the frequency while the standard overvoltage function on the right is insensitive to frequency. The network frequency, 50 Hz or 60 Hz, is automatically adopted by the relay.

The setting unit is per unit (PU).

$$1PU = \frac{U_{RATED}}{f_{RATED}}$$

U_{RATED} is the nominal voltage of the protected device and f_{RATED} is the basic network frequency.

Table 6.25: Parameters of the volts/hertz over-excitation stage $U_{\dot{f}}$, $U_{\dot{f}}>>$

Parameter	Value	Unit	Description	Note
Status	- Blocked Start Trip		Current status of the stage	 F F
SCntr			Cumulative start counter	C
TCntr			Cumulative trip counter	C
SetGrp	1, 2, 3, 4		Active setting group	Set
SGrpDI	- DIx VIx LEDx VOx		Digital signal to select the active setting group None Digital input Virtual input LED indicator signal Virtual output	Set
Force	Off On		Force flag for status forcing for test purposes. This is a common flag for all stages and output relays, too. Automatically reset by a 5-minute timeout.	Set
Umax		V	The supervised value. Max. of U12, U23 and U31	
f		Hz	The supervised frequency value	
U/f		%	Calculated U_{MAX}/f	
Uf>, Uf>>		%	Pick-up setting	Set
t>, t>>		s	Definite operate time	Set

Set = An editable parameter (password needed). C = Can be cleared to zero. F = Editable when force flag is on.

For details of setting ranges, see Table 11.34.

Recorded values of the latest eight faults

There are detailed information available of the eight latest faults: Time stamp, fault voltage, fault frequency, elapsed delay and setting group.

Table 6.26: Recorded values of the volts/hertz over-excitation stage

Parameter	Value	Unit	Description
	yyyy-mm-dd		Time stamp of the recording, date
	hh:mm:ss.ms		Time stamp, time of day
Flt		%	Fault value V/Hz
U		% Un	Fault voltage
f		Hz	Fault frequency
EDly		%	Elapsed time of the operate time setting. 100% = trip
SetGrp	1, 2, 3, 4		Active setting group during fault

6.14 Synchrocheck (25)

The relay includes a synchrocheck function that checks the synchronism before giving or enabling the circuit breaker close command. The function monitor voltage amplitude, frequency and phase angle difference between two voltages. Since there are two stages available, it is possible to monitor three voltages. The voltages can be busbar and line or busbar and busbar (bus coupler).

The Synchrocheck function is available when one of the following analog measurement modules and a suitable measuring mode is in use:

Analog measurement card	Voltage measuring mode	No. of synchrocheck stages
C = 3L+4U+2Io (5+1 A)	3LN+LLy	1
D = 3L+4U+2Io (1+0.2 A)	3LN+LNy	1
W = 3L(1A)+4U+2Io (5+1A)	2LL+Uo+LLy	1
	2LL+Uo+LNy	1
	LL+Uo+LLy+LLz	2
	LN+Uo+LNy+LNz	2

6.14.1 Connections for synchrocheck

The voltage used for synchrochecking is always phase-to-phase voltage U12. The synchrocheck stage 1 always compares U12 with U12y. The compared voltages for the stage 2 can be selected (U12 / U12y, U12 / U12z, U12y / U12z). See Chapter 4.9 Voltage measurement modes.

Table 6.27: Setting parameters of synchrocheck stages SyC1, SyC2 (25)

Parameter	Value	Unit	Default	Description
Side	U12/U12y; U12/U12z; U12y/U12z	-	U12/U12z	Voltage selection. The stage 1 has fixed voltages U12/U12y.
CBObj	Obj1 – Obj6	-	Obj1	The selected object for CB control. The synchrocheck closing command will use the closing command of the selected object.
CBObj2	Obj1 – Obj6	-	Obj2	The selected object for CB control. The synchrocheck closing command will use the closing command of the selected object.
ObjSel	Digital inputs	-	-	Input for selecting between CBObj1 and CBObj2. When active CBObj2 is in use

Parameter	Value	Unit	Default	Description
Smode	Async; Sync; Off	-	Sync	Synchrocheck mode. Off = only voltage check Async = the function checks dU, df and dangle. Furthermore, the frequency slip, df, determines the remaining time for closing. This time must be longer than "CB time". Sync mode = Synchronization is tried to make exactly when angle difference is zero. In this mode df-setting should be enough small (<0.3Hz).
Umode	-, DD, DL, LD, DD/DL, DD/LD, DL/LD, DD/DL/LD	-	-	Voltage check mode: The first letter refers to the reference voltage and the second letter refers to the comparison voltage. D means that the side must be "dead" when closing (dead = The voltage below the dead voltage limit setting) L means that the side must be "live" when closing (live = The voltage higher than the live voltage limit setting) Example: DL mode for stage 1: The U12 side must be "dead" and the U12y side must be "live".
Cbtime	0.04 – 0.6	s	0.1	Typical closing time of the circuit-breaker.
Dibypass	Digital inputs	-	-	Bypass input. If the input is active, the function is bypassed.
Bypass	0; 1	-	0	The bypass status. "1" means that the function is bypassed. This parameter can also be used for manual bypass.
CBCtrl	Open;Close	-	-	Circuit-breaker control
ShowInfo	Off; On	-	On	Additional information display about the synchrocheck status to the mimic display.
SGrpDI	Digital inputs	-	-	The input for changing the setting group.
SetGrp	1, 2, 3, 4	-	1	The active setting group.

Table 6.28: Measured and recorded values of synchrocheck stages SyC1, SyC2 (25)

	Parameter	Value	Unit	Description
Measured values	df	-	Hz	Measured frequency difference
	dU	-	% Un / deg	Measured voltage amplitude and phase angle difference
	UState	-	-	Voltage status (e.g. DD)
	SState	-	-	Synchrocheck status
	ReqTime	-	-	Request time status
	f ¹⁾	-	Hz	Measured frequency (reference side)
	f _y ¹⁾	-	Hz	Measured frequency (comparison side)
	U12 ¹⁾	-	% Un	Measured voltage (reference side)
U12 _y ¹⁾	-	% Un	Measured voltage (comparison side)	

	Parameter	Value	Unit	Description
Recorded values	ReqCntr	-	-	Request counter
	SyncCntr	-	-	Synchronising counter
	FailCntr	-	-	Fail counter
	f ¹⁾	-	Hz	Recorded frequency (reference side)
	f _y ¹⁾	-	Hz	Recorded frequency (comparison side)
	U12 ¹⁾	-	% Un	Recorded voltage (reference side)
	U12 _y ¹⁾	-	% Un	Recorded voltage (comparison side)
	dAng	-	Deg	Recorded phase angle difference, when close command is given from the function
	dAngC	-	Deg	Recorded phase angle difference, when the circuit-breaker actually closes.
	EDly	-	%	The elapsed time compared to the set request timeout setting, 100% = timeout

1) Please note that the labels (parameter names) change according to the voltage selection.

For details of setting ranges, see Table 11.53

The following signals of the stage are available in the output matrix and the logic: “Request”, “OK” and “Fail”. The “request”-signal is active, when a request has received but the breaker is not yet closed. The “OK”-signal is active, when the synchronising conditions are met, or the voltage check criterion is met. The “fail”-signal is activated, if the function fails to close the breaker within the request timeout setting. See below the figure.

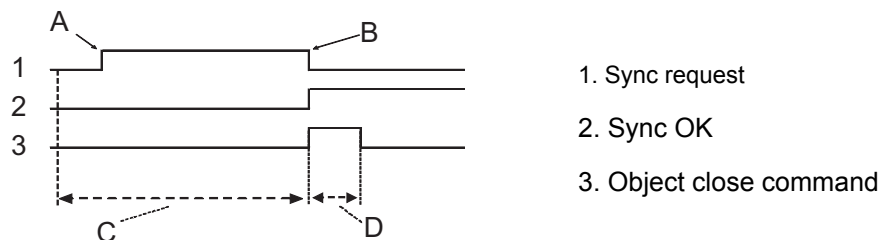

- A. Object close command given (minic or bus) actually make only sync request
- B. Request going down when "real" object close being requested
- C. Synchronizing time if timeout happens, Sync_Fail signal activates Timeout defined in synchrocheck
- D. Normal object close operation

Figure 6.32: The principle of the synchrocheck function

Please note that the control pulse of the selected object should be long enough. For example, if the voltages are in opposite direction, the synchronising conditions are met after several seconds.

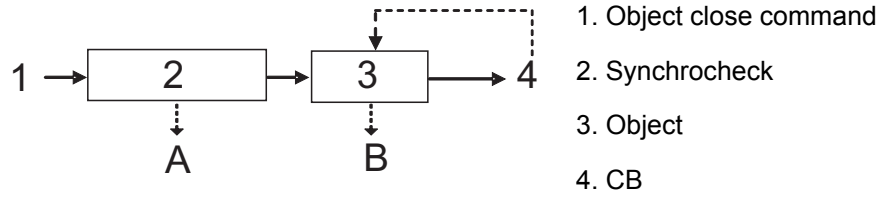

A. Sync_Fail signal if sync timeout happen
 B. Object_Fail signal if "real" object control fail.

Time settings:

- Synchrocheck: Max synchronize time (~seconds)
- Object: Max object control pulse len (~200 ms)

Figure 6.33: The block diagram of the synchrocheck and the controlling object

Please note that the wiring of the secondary circuits of voltage transformers to the device terminal depends on the selected voltage measuring mode.

Table 6.29: Voltage measurement modes for synchrocheck function

Terminal	8/C/2, 8/D/2, 8/W/2						8/C/1, 8/D/1, 8/W/1	
	1	2	3	4	5	6	11	12
Voltage channel	U1		U2		U3		U4	
Mode / Used voltage								
3LN+LLy	UL1		UL2		UL3		LLy	
3LN+LNy							LNy	
2LL+U ₀ +LLy	U12		U23		U ₀		LLy	
2LL+U ₀ +LNy							LNy	
LL+U ₀ +LLy+LLz			U12y				U12z	
LN+U ₀ +LNy+LNz			UL1				UL1y	

See synchrocheck stages connection diagrams in Chapter 4.9 Voltage measurement modes.

6.15 Undervoltage protection U< (27)

This is a basic undervoltage protection. The function measures the three line-to-line voltages and whenever the smallest of them drops below the user's pick-up setting of a particular stage, this stage picks up and a start signal is issued. If the fault situation remains on longer than the user's operate time delay setting, a trip signal is issued.

Blocking during VT fuse failure

As all the protection stages the undervoltage function can be blocked with any internal or external signal using the block matrix. For example if the secondary voltage of one of the measuring

transformers disappears because of a fuse failure (See VT supervision function in Chapter 7.8 Voltage transformer supervision). The blocking signal can also be a signal from the user's logic (see Chapter 5.6 Logic functions).

Self blocking at very low voltage

The stages can be blocked with a separate low limit setting. With this setting, the particular stage will be blocked, when the biggest of the three line-to-line voltages drops below the given limit. The idea is to avoid purposeless tripping, when voltage is switched off. If the operate time is less than 0.08 s, the blocking level setting should not be less than 15 % to the blocking action to be enough fast. The self blocking can be disabled by setting the low voltage block limit equal to zero.

Figure 6.34 shows an example of low voltage self blocking.

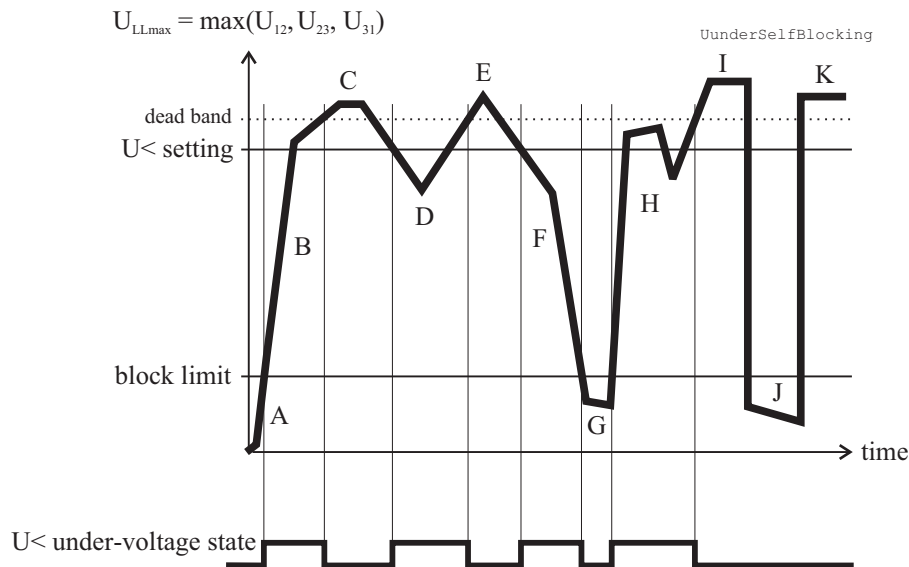

Figure 6.34: Under voltage state and block limit.

- | | | | |
|---|--|---|--|
| A | The maximum of the three line-to-line voltages U_{LLmax} is below the block limit. This is not regarded as an under voltage situation. | F | This is an under voltage situation. |
| B | The voltage U_{LLmin} is above the block limit but below the pick-up level. This is an undervoltage situation. | G | The voltage U_{LLmin} is under block limit and this is not regarded as an under voltage situation. |
| C | Voltage is OK, because it is above the pick-up limit. | H | This is an under voltage situation. |
| D | This is an under voltage situation. | I | Voltage is OK. |
| E | Voltage is OK. | J | Same as G |
| | | K | Voltage is OK. |

Three independent stages

There are three separately adjustable stages: U<, U<< and U<<<. All these stages can be configured for definite time (DT) operation characteristic.

Setting groups

There are four settings groups available for all stages. Switching between setting groups can be controlled by digital inputs, virtual inputs (mimic display, communication, logic) and manually. See Chapter 6.2 General features of protection stages for more details.

Table 6.30: Parameters of the under voltage stages U<, U<<, U<<<

Parameter	Value	Unit	Description	Note
Status	-		Current status of the stage	
	Blocked			
	Start			F
	Trip			F
SCntr			Cumulative start counter	C
TCntr			Cumulative trip counter	C
SetGrp	1, 2, 3, 4		Active setting group	Set
SGrpDI			Digital signal to select the active setting group	Set
	-		None	
	DIx		Digital input	
	VIx		Virtual input	
	LEDx		LED indicator signal	
	VOx		Virtual output	
	Fx		Function key	
Force	Off		Force flag for status forcing for test purposes. This is a common flag for all stages and output relays, too. Automatically reset by a 5-minute timeout.	Set
	On			
MinU		V	The supervised minimum of line-to-line voltages in primary volts	
U<, U<<, U<<<		V	Pick-up value scaled to primary value	
U<, U<<, U<<<		% Un	Pick-up setting	Set
t<, t<<, t<<<		S	Definite operate time	Set
LVBik		% Un	Low limit for self blocking	Set
RlsDly		S	Release delay (U< stage only)	Set
Hyster	Default 3.0 %	%	Dead band setting	Set

Set = An editable parameter (password needed). C = Can be cleared to zero. F = Editable when force flag is on.

For details of setting ranges, see Table 11.36, Table 11.37, Table 11.38.

Recorded values of the latest eight faults

There are detailed information available of the eight latest faults for each of the stages: Time stamp, fault voltage, elapsed delay, voltage before the fault and setting group.

Table 6.31: Recorded values of the undervoltage stages (8 latest faults) U<, U<<, U<<<

Parameter	Value	Unit	Description
	yyyy-mm-dd		Time stamp of the recording, date
	hh:mm:ss.ms		Time stamp, time of day
Flt		% Un	Minimum fault voltage
EDly		%	Elapsed time of the operate time setting. 100% = trip
PreFlt		% Un	Supervised value before fault, 1 s average value.
SetGrp	1, 2, 3, 4		Active setting group during fault

6.16 Undervoltage protection $U_1 <$ (27P)

This is a special undervoltage protection for generator applications, where the voltage is measured at the generator side of the generator circuit breaker. There are special self blocking features for starting up and shutting down a generator.

This undervoltage function measures the positive sequence of fundamental frequency component U_1 of the measured voltages (for calculation of U_1 , see Chapter 4.11 Symmetric components). By using positive sequence all the three phases are supervised with one value and in case the generator loses connection to the network (loss of mains), the undervoltage situation is detected faster than by using just the minimum of the three line-to-line voltages.

Whenever the positive sequence voltage U_1 drops below the user's pick-up setting of a particular stage, this stage picks up and a start signal is issued. If the fault situation remains on longer than the user's operate time delay setting, a trip signal is issued.

Blocking during VT fuse failure

As all the protection stages the undervoltage function can be blocked with any internal or external signal using the block matrix. For example if the secondary voltage of one of the measuring transformers disappears because of a fuse failure (See VT supervision function in Chapter 7.8 Voltage transformer supervision). The blocking signal can also be a signal from the user's logic (see Chapter 5.6 Logic functions).

Self blocking at very low voltage

The stages will be blocked when the voltage is below a separate low voltage blocking setting. With this setting, LVBlk, both stages are blocked, when the voltage U_1 drops below the given limit. The idea is to avoid purposeless alarms, when the generator is not running. The LVBlk setting is common for both stages. The self blocking can not be disabled.

Temporary self blocking at very low currents

Further the pick up can be delayed by using setting I<Blk. When the maximum of the three measured phase currents is less than 1 % of the rated generator current, this delay is enabled. The idea is to avoid purposeless alarms, when the generator circuit breaker is open and the excitation is switched off. By setting the delay equal to zero, this feature is disabled.

Initial self blocking

When the voltage U_1 has been below the block limit, the stages will be blocked until the pick-up setting has been reached.

Figure 6.35 shows an example of low voltage self blocking.

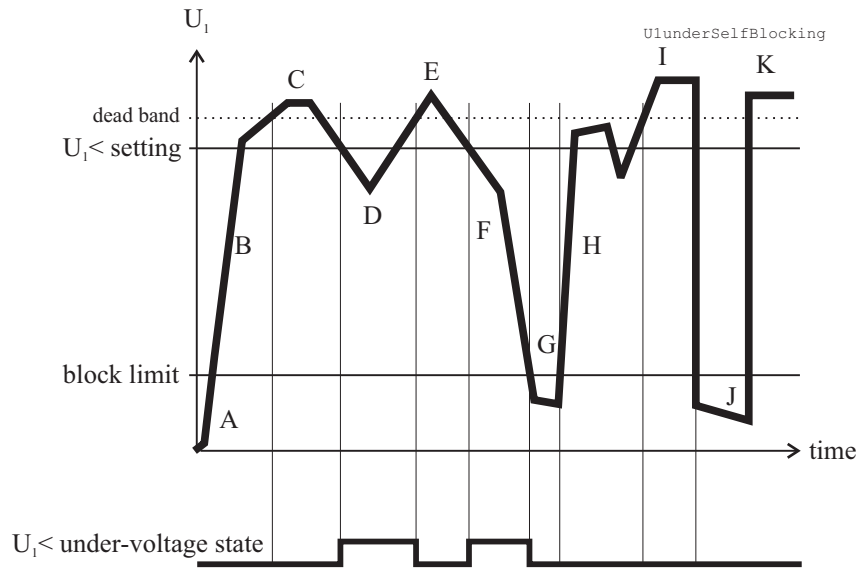

Figure 6.35: Positive sequence under voltage state and block limit.

- | | | | |
|---|--|---|--|
| A | The positive sequence voltage U_1 is below the block limit. This is not regarded as an under voltage situation. | F | This is an under voltage situation. |
| B | The positive sequence voltage U_1 is above the block limit but below the pick-up level. However, this is not regarded as an under voltage situation, because the voltage has never been above the pick-up level since being below the block limit. | G | Voltage is under block limit and this is not regarded as an under voltage situation. |
| C | Voltage is OK, because it is above the pick-up limit. | H | Same as B. |
| D | This is an under voltage situation. | I | Voltage is OK. |
| E | Voltage is OK. | J | Same as G. |
| | | K | Voltage is OK. |

Two independent stages

There are two separately adjustable stages: $U_1 <$ and $U_1 <<$. Both stages can be configured for definite time (DT) operation characteristic.

Setting groups

There are four settings groups available for each stage. Switching between setting groups can be controlled by digital inputs, virtual inputs (communication, logic) and manually. See Chapter 6.2 General features of protection stages for more details.

Table 6.32: Parameters of the under voltage stages $U_1<$, $U_1<<$

Parameter	Value	Unit	Description	Note
Status	- Blocked Start Trip		Current status of the stage	F F
SCntr			Cumulative start counter	C
TCntr			Cumulative trip counter	C
SetGrp	1 or 2		Active setting group	Set
SGrpDI	- DIx VIx LEDx VOx		Digital signal to select the active setting group None Digital input Virtual input LED indicator signal Virtual output	Set
Force	Off On		Force flag for status forcing for test purposes. This is a common flag for all stages and output relays, too. Automatically reset by a 5-minute timeout.	Set
U1		V	The supervised positive sequence voltage in primary volts	
U1		%	The supervised positive sequence voltage of $U_n / \sqrt{3}$	
U1<, U1<<		V	Pick-up value scaled to primary value	
U1<, U1<<		%	Pick-up setting of $U_n / \sqrt{3}$	Set
t<, t<<		s	Definite operate time	Set
LVBk		% U_n	Low limit for self blocking. This is a common setting for both stages.	Set
I<Bk		s	Pick up delay, when current is less than 1 % I_{GN} .	Set

Set = An editable parameter (password needed). C = Can be cleared to zero. F = Editable when force flag is on.

For details of setting ranges, see Table 11.35

Recorded values of the latest eight faults

There are detailed information available of the eight latest faults: Time stamp, fault voltage, elapsed delay and setting group.

Table 6.33: Recorded values of the undervoltage stages (8 latest faults)

Parameter	Value	Unit	Description
	yyyy-mm-dd		Time stamp of the recording, date
	hh:mm:ss.ms		Time stamp, time of day
Flt		% U_n	Minimum fault voltage
EDly		%	Elapsed time of the operate time setting. 100% = trip
SetGrp	1 2		Active setting group during fault

6.17 Zero sequence voltage protection $U_0>$ (59N)

The zero sequence voltage protection is used as unselective backup for earth faults and also for selective earth fault protections for motors having a unit transformer between the motor and the busbar.

This function is sensitive to the fundamental frequency component of the zero sequence voltage. The attenuation of the third harmonic is more than 60 dB. This is essential, because 3rd harmonics exist between the neutral point and earth also when there is no earth fault.

Whenever the measured value exceeds the user's pick-up setting of a particular stage, this stage picks up and a start signal is issued. If the fault situation remains on longer than the user's operate time delay setting, a trip signal is issued.

Measuring the zero sequence voltage

The zero sequence voltage is either measured with three voltage transformers (e.g. broken delta connection), one voltage transformer between the motor's neutral point and earth or calculated from the measured phase-to-neutral voltages according to the selected voltage measurement mode (see Chapter 4.9 Voltage measurement modes):

- When the voltage measurement mode is 3LN: the zero sequence voltage is calculated from the phase voltages and therefore a separate zero sequence voltage transformer is not needed. The setting values are relative to the configured voltage transformer (VT) voltage/ $\sqrt{3}$.
- When the voltage measurement mode contains "+ U_0 ": The zero sequence voltage is measured with voltage transformer(s) for example using a broken delta connection. The setting values are relative to the VT_0 secondary voltage defined in configuration.

NOTE: The U_0 signal must be connected according the connection diagram in order to get a correct polarization. Please note that actually the negative U_0 , $-U_0$, is to be connected to the relay.

Two independent stages

There are two separately adjustable stages: $U_0>$ and $U_0>>$. Both stages can be configured for definite time (DT) operation characteristic.

The zero sequence voltage function comprises two separately adjustable zero sequence voltage stages (stage $U_0>$ and $U_0>>$).

Setting groups

There are four settings groups available for both stages. Switching between setting groups can be controlled by digital inputs, virtual inputs (communication, logic) and manually. See Chapter 6.2 General features of protection stages for more details.

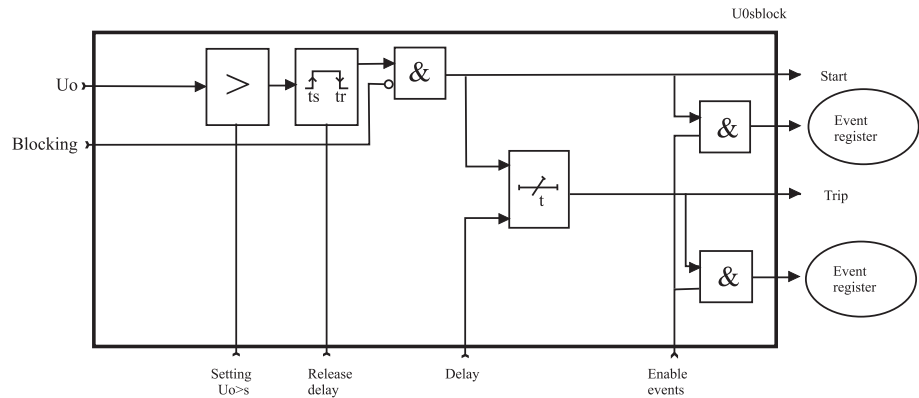

Figure 6.36: Block diagram of the zero sequence voltage stages $U_0>$, $U_0>>$

Table 6.34: Parameters of the residual overvoltage stages $U_0>$, $U_0>>$

Parameter	Value	Unit	Description	Note
Status	- Blocked Start Trip		Current status of the stage	 F F
SCntr			Cumulative start counter	C
TCntr			Cumulative trip counter	C
SetGrp	1, 2, 3, 4		Active setting group	Set
SGrpDI			Digital signal to select the active setting group	Set
	-		None	
	Dlx		Digital input	
	Vlx		Virtual input	
	LEDx		LED indicator signal	
	VOx		Virtual output	
Force	Off On		Force flag for status forcing for test purposes. This is a common flag for all stages and output relays, too. Automatically reset by a 5-minute timeout.	Set
	U_0	%	The supervised value relative to $U_n/\sqrt{3}$	
$U_0>$, $U_0>>$		%	Pick-up value relative to $U_n/\sqrt{3}$	Set
$t>$, $t>>$		s	Definite operate time	Set

Set = An editable parameter (password needed). C = Can be cleared to zero. F = Editable when force flag is on.

For details of setting ranges, see Table 11.39, Table 11.40.

Recorded values of the latest eight faults

There are detailed information available of the eight latest faults: Time stamp, fault voltage, elapsed delay and setting group.

Table 6.35: Recorded values of the residual overvoltage stages $U_{0>}$, $U_{0>>}$

Parameter	Value	Unit	Description
	yyyy-mm-dd		Time stamp of the recording, date
	hh:mm:ss.ms		Time stamp, time of day
Flt		%	Fault voltage relative to $U_n / \sqrt{3}$
EDly		%	Elapsed time of the operate time setting. 100% = trip
SetGrp	1, 2, 3, 4		Active setting group during fault

6.18 100% stator earth fault $U_{0F3} <$ (64F3)

NOTE: This protection stage is available only in voltage measurement mode "2LL + U_0 and 3LN + U_0 " (see chapter Chapter 4.9 Voltage measurement modes).

For this function the zero sequence voltage must be measured from the generator's neutral point and the earth.

A unit transformer is usually needed between the generator and the busbar for selective operation of this function.

The third harmonic undervoltage stage can be used to detect earth-faults near a high impedance earthed generator's neutral point or even at the neutral point. These kind of faults are rare, but if a second earth-fault would occur in one of the phases the consequences would be severe, because the first earth-fault had made the network solidly earthed. By using the $U_{0F3} <$ stage such situation can be avoided.

Neutral point is a blind point for conventional earth fault function

In case there is an earth-fault near the neutral point or even at the neutral point, the residual current and zero sequence voltage caused by such fault are negligible or even zero. Thus a conventional earth-fault protection based on fundamental frequency I_0 and/or U_0 measurement is not able to detect such faults. On the other hand, faults near the neutral point are rare, because the voltage stress is low.

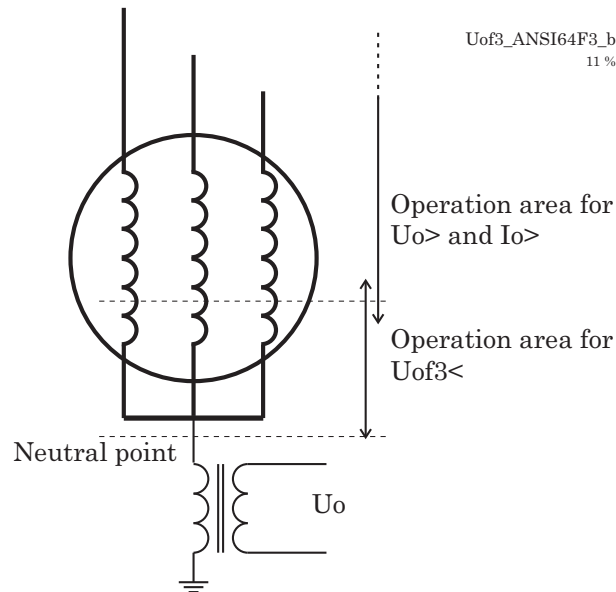

Figure 6.37: The overlapping coverage of winding earth-fault protection of basic protection stages and the third harmonic undervoltage protection stage.

100 % coverage of the windings

The "one hundred per cent" in the title is slightly misleading. Actually the 100 % coverage is achieved only when this stage is used together with conventional earth fault protection.

The operation range of fundamental frequency earth-fault functions 59N and 51N covers about 95 % of the stator windings starting from the HV end, but never 100 % of the windings. The coverage of the $U_{0f3}<$ stage is about 10% – 30 % of the windings but starting from the LV end, i.e. the neutral point. Thus the ranges do overlap as in Figure 6.37 and 59N or 51N together with this 64F3 does cover 100 % of the stator windings.

Natural 3rd harmonic at the neutral point

The voltage a generator is not ideal pure sine wave. There will exist some small amount of harmonics as well. At the neutral point there will exist some amount of 3rd, 6th, 9th, 12th ..., i.e. $3n$ harmonics. The base frequency and other than $3n$ harmonics in phase voltages do cancel each other at the neutral point (Figure 6.38 and Figure 6.39). The third harmonic residual undervoltage stage $U_{0f3}<$ is supervising the level of the 3rd harmonic at the neutral point. If there is an earth fault near the neutral point, this 150 Hz or 180 Hz voltage drops below setting and the stage will pick up.

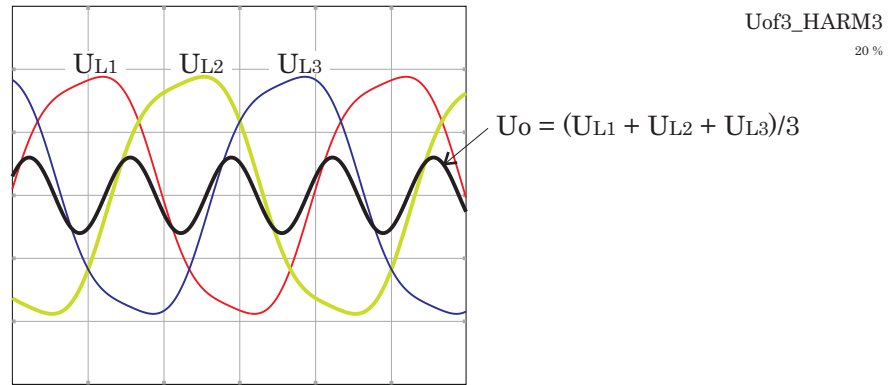

Figure 6.38: When symmetric phase-to-ground voltages containing third harmonic are summed together, the result is not zero.

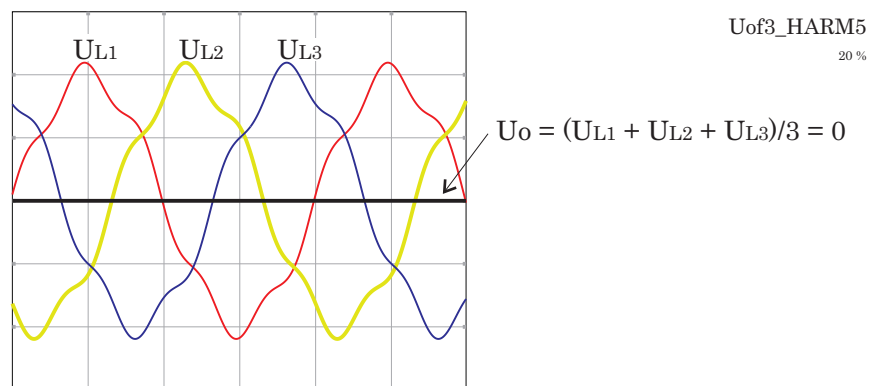

Figure 6.39: When the phase-to-ground voltages do contain fifth harmonic, they cancel each other when summed and the resulting zero sequence voltage U_0 will be zero.

Finding out the correct pick-up setting

A problem with this third harmonic undervoltage stage is to find a proper pick-up setting. In practice an empirical value is used, because the natural 3rd harmonic at the neutral point is dependent on:

- Construction of the generator
- Loading and the power factor
- Loading and the power factor
- Amount of excitation
- Earthing circuitry
- Transformers connected.

The relay itself can be used to measure the actual level of 3rd U_0 harmonic during various situations. Typically the generator is producing its minimum amount of 3rd harmonic when the load is small and the excitation is low. The pick-up setting must be below this minimum value. A typical operation delay is one minute.

Blocking the protection

The squelch of voltage measurement will block the stage when the generator is stopped. Using the block matrix, blocking by under-voltage, under-power, CB position and other blocking schemes are possible.

Setting groups

There are two settings groups available. Switching between setting groups can be controlled by digital inputs, virtual inputs (mimic display, communication, logic) and manually.

Table 6.36: Parameters of the 100 % stator earth fault stage $U_{0F3}<$ (64F3)

Parameter	Value	Unit	Description	Note
Status	- Blocked Start Trip		Current status of the stage	
SCntr			Cumulative start counter	
TCntr			Cumulative trip counter	
SetGrp	1, 2, 3, 4		Active setting group	
SGrpDI	- DIx VIx LEDx VOx		Digital signal to select the active setting group None Digital input Virtual input LED indicator signal Virtual output	
Force	Off On		Force flag for status forcing for test purposes. This is a common flag for all stages and output relays, too. Automatically reset by a 5-minute timeout.	
Uof3		%	The supervised value relative to U_{0N} . For U_{0N} , see Chapter 4.5 Harmonics and Total Harmonic Distortion (THD).	
Uof3<		%	Pick-up value relative to U_{0N} . For U_{0N} , see Chapter 4.5 Harmonics and Total Harmonic Distortion (THD).	
t<		min	Definite operate time in minutes	

Set = An editable parameter (password needed). C = Can be cleared to zero. F = Editable when force flag is on.

For details of setting ranges, see Table 11.41

Recorded values of the latest eight faults

There are detailed information available of the eight latest faults: Time stamp, fault voltage, elapsed delay and setting group.

Table 6.37: Recorded values of the 100 % stator earth fault stage $U_{0F3} < (64F3)$

Parameter	Value	Unit	Description
	yyyy-mm-dd		Time stamp of the recording, date
	hh:mm:ss.ms		Time stamp, time of day
Flt		%	3rd harmonic value relative to $U_n / \sqrt{3}$ during fault
EDly		%	Elapsed time of the operate time setting. 100% = trip
SetGrp	1, 2, 3, 4		Active setting group during fault

6.19 Frequency Protection f><, f>><< (81)

Frequency protection is used for load sharing, loss of mains detection and as a backup protection for over-speeding.

The frequency function measures the frequency from the two first voltage inputs. At least one of these two inputs must have a voltage connected to be able to measure the frequency. Whenever the frequency crosses the user's pick-up setting of a particular stage, this stage picks up and a start signal is issued. If the fault remains on longer than the operate delay setting, a trip signal is issued. For situations, where no voltage is present an adapted frequency is used.

Protection mode for f>< and f>><< stages

These two stages can be configured either for overfrequency or for underfrequency.

Under voltage self blocking of underfrequency stages

The underfrequency stages are blocked when biggest of the three line-to-line voltages is below the low voltage block limit setting. With this common setting, LVBlk, all stages in underfrequency mode are blocked, when the voltage drops below the given limit. The idea is to avoid purposeless alarms, when the voltage is off.

Initial self blocking of underfrequency stages

When the biggest of the three line-to-line voltages has been below the block limit, the under frequency stages will be blocked until the pick-up setting has been reached.

Four independent frequency stages

There are four separately adjustable frequency stages: f><, f>><<, f<, f<<. The two first stages can be configured for either overfrequency or underfrequency usage. So totally four underfrequency stages can be in use simultaneously. Using the programmable stages even more can be implemented (chapter Chapter 6.30 Programmable stages (99)). All the stages have definite operate time delay (DT).

Setting groups

There are four settings groups available for each stage. Switching between setting groups can be controlled by digital inputs, virtual inputs (mimic display, communication, logic) and manually. See Chapter 6.2 General features of protection stages for more details.

Table 6.38: Parameters of the over & underfrequency stages

Parameter	Value	Unit	Description	Note
Status	- Blocked Start Trip		Current status of the stage	F F
SCntr			Cumulative start counter	C
TCntr			Cumulative trip counter	C
SetGrp	1, 2, 3, 4		Active setting group	Set
SGrpDI			Digital signal to select the active setting group	Set
	-		None	
	DIx		Digital input	
	VIx		Virtual input	
	LEDx		LED indicator signal	
	VOx		Virtual output	
	Fx		Function key	
Force	Off On		Force flag for status forcing for test purposes. This is a common flag for all stages and output relays, too. Automatically reset by a 5-minute timeout.	Set
f		Hz	The supervised value.	
fX		Hz	Pick-up value	Set
fXX			Over/under stage f><. See row "Mode".	
f<			Over/under stage f>><<.	
f<<			Under stage f<	
			Under stage f<<	
tX		s	Definite operate time	Set
tXX			f>< stage	
t<			f>><< stage	
t<<			f< stage	
			f<< stage	
Mode	> <		Operation mode. (only for f>< and f>><<) Overfrequency mode Underfrequency mode	Set
LVbck		% Un	Low limit for self blocking. This is a common setting for all four stages.	Set

Set = An editable parameter (password needed). C = Can be cleared to zero. F = Editable when force flag is on.

For details of setting ranges, see Table 11.45, Table 11.46.

Recorded values of the latest eight faults

There are detailed information available of the eight latest faults:
Time stamp, frequency during fault, elapsed delay and setting group.

Table 6.39: Recorded values of the over & under frequency stages (8 latest faults) $f > <$, $f >> <<$, $f <$, $f <<$

Parameter	Value	Unit	Description
	yyyy-mm-dd		Time stamp of the recording, date
	hh:mm:ss.ms		Time stamp, time of day
Flt		Hz	Faulty frequency
EDly		%	Elapsed time of the operate time setting. 100% = trip
SetGrp	1, 2, 3, 4		Active setting group during fault

6.20 Rate of change of frequency (ROCOF) (81R)

Rate of change of frequency (ROCOF or df/dt) function is used for fast load shedding, to speed up operate time in over- and under-frequency situations and to detect loss of grid. For example a centralized dedicated load shedding relay can be omitted and replaced with distributed load shedding, if all outgoing feeders are equipped with VAMP devices.

A special application for ROCOF is to detect loss of grid (loss of mains, islanding). The more the remaining load differs from the load before the loss of grid, the better the ROCOF function detects the situation.

Frequency behaviour during load switching

Load switching and fault situations may generate change in frequency. A load drop may increase the frequency and increasing load may decrease the frequency, at least for a while. The frequency may also oscillate after the initial change. After a while the control system of any local generator may drive the frequency back to the original value. However, in case of a heavy short circuit fault or in case the new load exceeds the generating capacity, the average frequency keeps on decreasing.

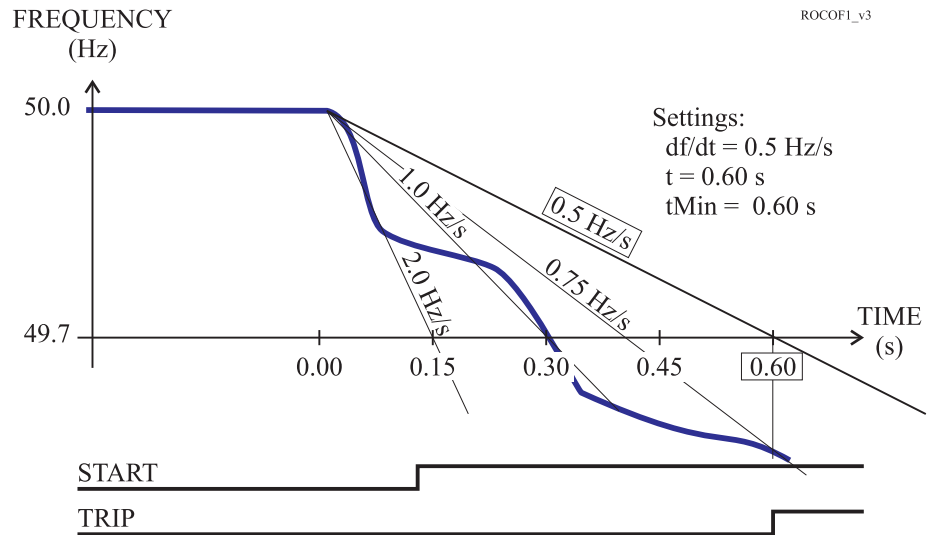

Figure 6.40: An example of definite time df/dt operate time. At 0.6 s, which is the delay setting, the average slope exceeds the setting 0.5 Hz/s and a trip signal is generated.

Setting groups

There are four settings groups available. Switching between setting groups can be controlled by digital inputs, virtual inputs (communication, logic) and manually. See Chapter 6.2 General features of protection stages for more details.

Description of ROCOF implementation

The ROCOF function is sensitive to the absolute average value of the time derivate of the measured frequency $|df/dt|$. Whenever the measured frequency slope $|df/dt|$ exceeds the setting value for 80 ms time, the ROCOF stage picks up and issues a start signal after an additional 60 ms delay. If the average $|df/dt|$, since the pick-up moment, still exceeds the setting, when the operation delay time has elapsed, a trip signal is issued. In this definite time mode the second delay parameter "minimum delay, t_{MIN} " must be equal to the operation delay parameter "t".

If the frequency is stable for about 80 ms and the time t has already elapsed without a trip, the stage will release.

ROCOF and frequency over and under stages

One difference between over-/under-frequency and df/dt function is the speed. In many cases a df/dt function can predict an overfrequency or underfrequency situation and is thus faster than a simple overfrequency or underfrequency function. However, in most cases a standard overfrequency and underfrequency stages must be used together with ROCOF to ensure tripping also in case the frequency drift is slower than the slope setting of ROCOF.

Definite operate time characteristics

Figure 6.40 shows an example where the df/dt pick-up value is 0.5 Hz/s and the delay settings are $t = 0.60$ s and $t_{MIN} = 0.60$ s. Equal times $t = t_{MIN}$ will give a definite time delay characteristics. Although the frequency slope fluctuates the stage will not release but continues to calculate the average slope since the initial pick-up. At the defined operate time, $t = 0.6$ s, the average slope is 0.75 Hz/s. This exceeds the setting, and the stage will trip.

At slope settings less than 0.7 Hz/s the fastest possible operate time is limited according the Figure 6.41

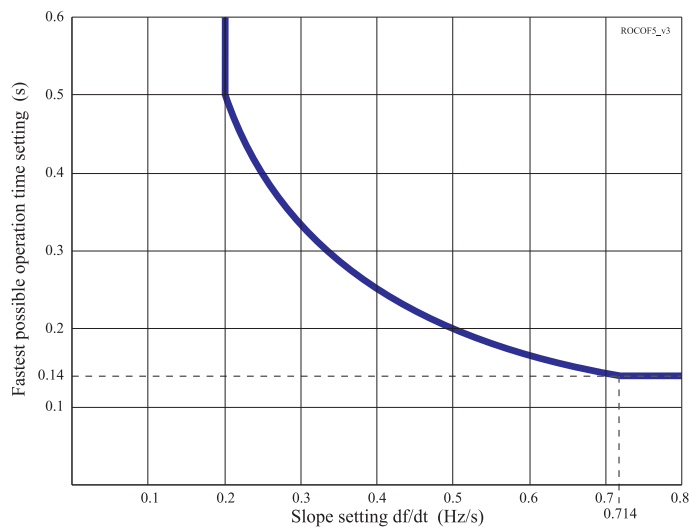

Figure 6.41: At very sensitive slope settings the fastest possible operate time is limited according the figure.

Inverse operate time characteristics

By setting the second delay parameter t_{MIN} smaller than the operational delay t , an inverse type of operate time characteristics is achieved.

Figure 6.43 shows one example, where the frequency behaviour is the same as in the first figure, but the t_{MIN} setting is 0.15 s instead of being equal with t . The operate time depends of the measured average slope according the following equation.

t_{TRIP} = Resulting operate time (seconds).

s_{SET} = df/dt i.e. slope setting (hertz/seconds).

t_{SET} = operate time setting t (seconds).

s = Measured average frequency slope (hertz/seconds).

Equation 6.6:

$$t_{TRIP} = \frac{s_{SET} \cdot t_{SET}}{|s|}$$

The minimum operate time is always limited by the setting parameter t_{MIN} . In the example of the fastest operate time, 0.15 s, is achieved when the slope is 2 Hz/s or more. The leftmost curve in Figure 6.42

shows the inverse characteristics with the same settings as in Figure 6.43.

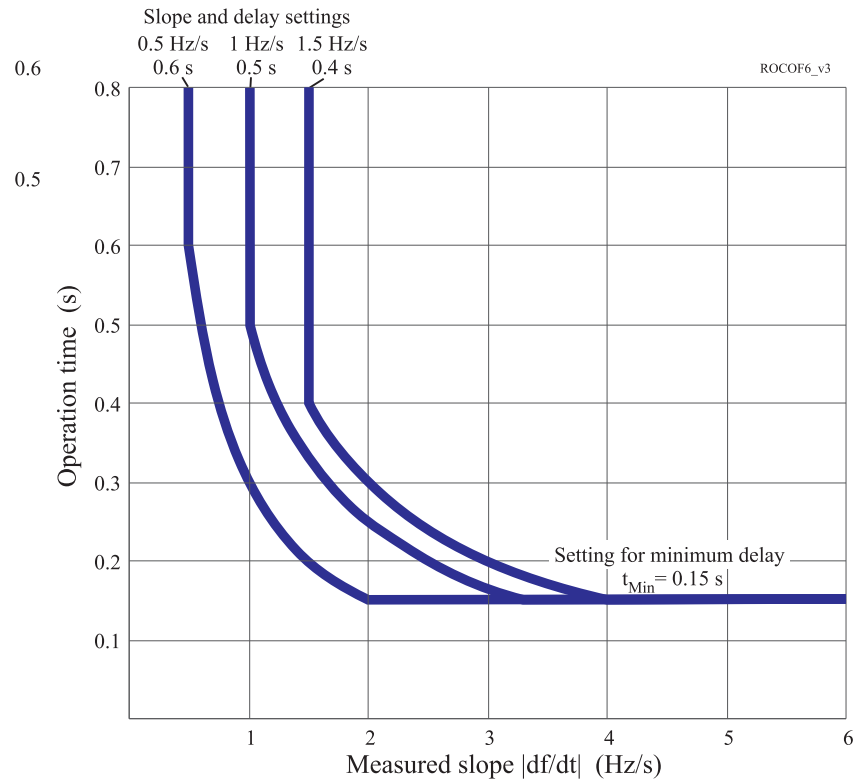

Figure 6.42: Three examples of possible inverse df/dt operate time characteristics. The slope and operation delay settings define the knee points on the left. A common setting for t_{Min} has been used in these three examples. This minimum delay parameter defines the knee point positions on the right.

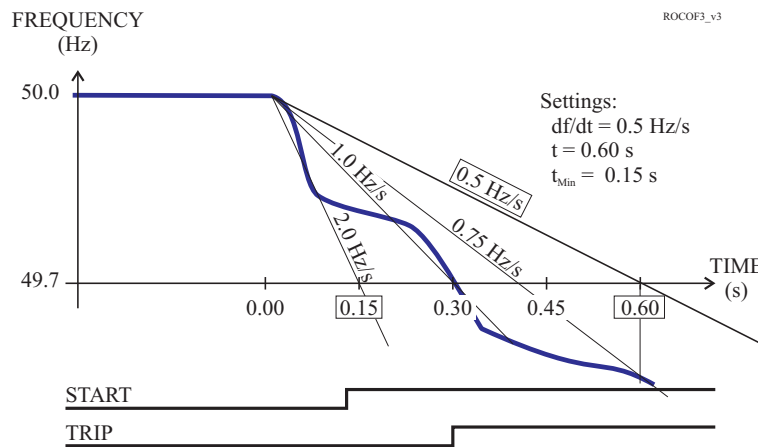

Figure 6.43: An example of inverse df/dt operate time. The time to trip will be 0.3 s, although the setting is 0.6 s, because the average slope 1 Hz/s is steeper than the setting value 0.5 Hz/s.

Table 6.40: Setting parameters of df/dt stage

Parameter	Value	Unit	Default	Description
df/dt	0.2 – 10.0	Hz/s	5.0	df/dt pick-up setting
t>	0.14 – 10.0	s	0.50	df/dt operational delay
tMin>	0.14 – 10.0	s	0.50	df/dt minimum delay
S_On	Enabled; Disabled	-	Enabled	Start on event
S_Off	Enabled; Disabled	-	Enabled	Start off event
T_On	Enabled; Disabled	-	Enabled	Trip on event
T_Off	Enabled; Disabled	-	Enabled	Trip off event

For details of setting ranges, see Table 11.47

Table 6.41: Measured and recorded values of df/dt stage

	Parameter	Value	Unit	Description
Measured value	f		Hz	Frequency
	df/dt		Hz/s	Frequency rate of change
Recorded values	SCntr		-	Start counter (Start) reading
	TCntr		-	Trip counter (Trip) reading
	Flt		%Hz/s	Max rate of change fault value
	EDly		%	Elapsed time as compared to the set operate time, 100% = tripping

6.21 Underimpedance Z< (21)

Underimpedance protection can be used to detect near short-circuit faults, even when excitation of the generator collapses and limits the available short-circuit current. It is an alternative for the voltage-dependent overcurrent protection (Chapter 6.5 Voltage restrained/controlled phase overcurrent $I_V >$ (51V)). When the generator's short-circuit current capacity is limited, an instantaneous overcurrent stage might not activate, but an underimpedance stage detects the fault. This fault is calculated using IL currents measured through the analog interface card in slot 8.

The stage is sensitive to positive sequence impedance Z_1 , which is calculated using the equation

$$Z_1 = \frac{U_1}{I_1}$$

Z_1 = absolute value of positive sequence impedance

U_1 = positive sequence voltage

I_1 = positive sequence current

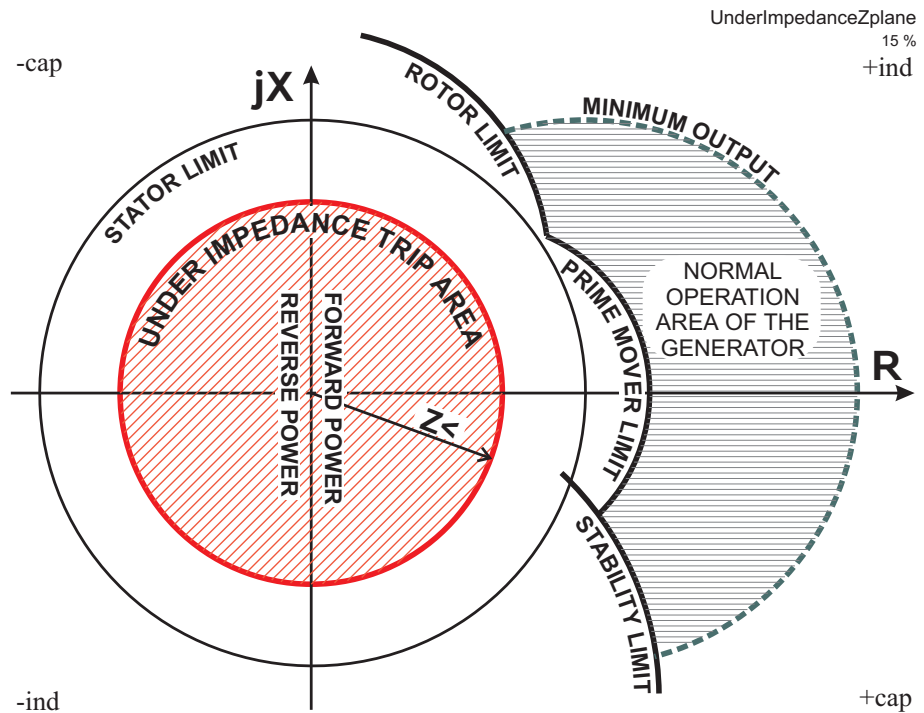

Figure 6.44: The trip region of underimpedance stage is a circle in origin. The radius $Z<$ is the setting value. The bigger circle "stator limit" represents the rated power of the generator.

The impedance relay is insensitive to the phase angle between current and voltage. Its characteristics in an impedance plane is a circle in origin, where the horizontal axis represents resistance R and the vertical axis represents reactance jX (Figure 6.44).

Whenever the positive sequence impedance goes inside the circle, the stage will pick-up. The radius $Z<$ of the circle and the definite delay time are the setting parameters.

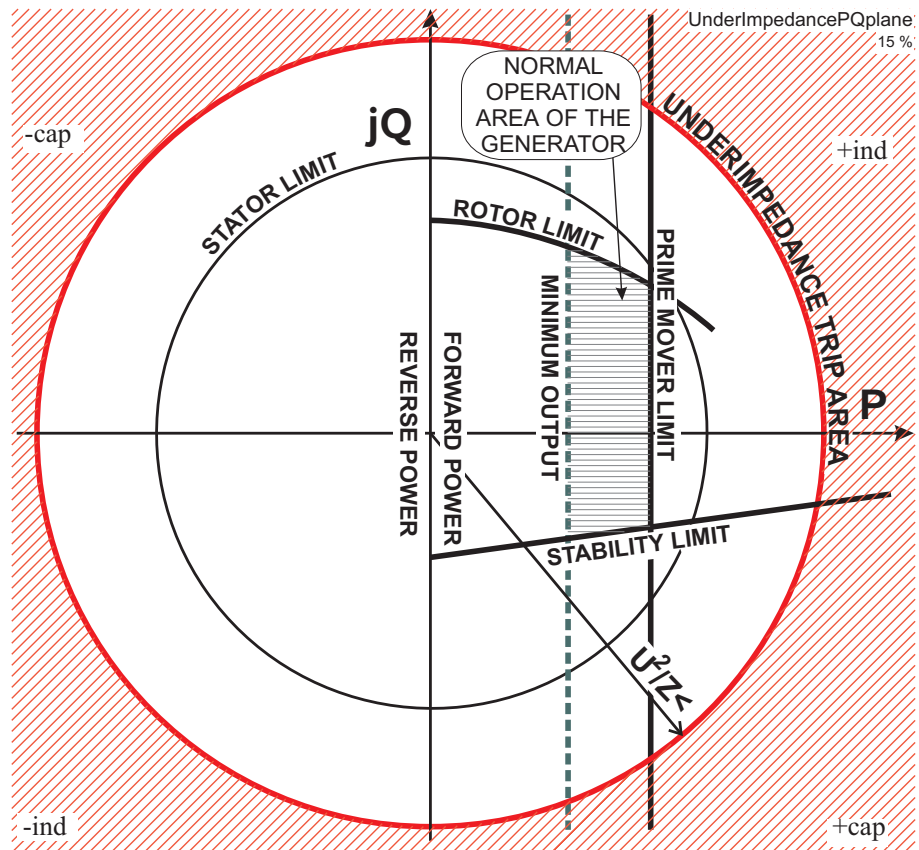

Figure 6.45: Underimpedance characteristics drawn in power plane assuming, that voltage is constant. The trip area is now outside of the circle having radius $U^2/Z<$, where $Z<$ is the pick-up setting.

Undercurrent blocking

When for some reason voltage collapses but currents remain at normal load levels, the calculated impedance may fall into the trip area. Inverted start signal from the most sensitive overcurrent stage can be used to block the underimpedance stages during abnormal voltages not caused by short circuit faults.

Characteristic on a PQ-power plane

In Figure 6.45 the same characteristics as in the previous figure is drawn on a PQ-power plane assuming a constant voltage of 1 PU. The transformation is $\underline{S} = U^2/Z^*$, where U is the voltage and Z^* is the complex conjugate of impedance Z .

The borderline of underimpedance trip area in the power plane is still a circle in origin, but now the trip area is the outside of the circle. The shape of the normal operation area is totally different. For example the maximum active power (prime mover limit) is just a vertical line while in impedance plane (Figure 6.44), it is a circle touching the jX axis.

When current is zero the impedance calculation gives infinite as result. Thus the stage will not pick-up in a machine stand still situation.

Two independent underimpedance stages

There are two separately adjustable stages available: Z< and Z<<.

Setting groups

There are four settings groups available for each stage. Switching between setting groups can be controlled by digital inputs, virtual inputs (communication, logic) and manually. See Chapter 6.2 General features of protection stages for more details.

Table 6.42: Parameters of the underimpedance stages Z<, Z<< (21)

Parameter	Value	Unit	Description	Note
Status	- Blocked Start Trip		Current status of the stage	 F F
TripTime		s	Estimated time to trip	
SCntr			Cumulative start counter	Clr
TCntr			Cumulative trip counter	Clr
SetGrp	1 or 2		Active setting group	Set
SGrpDI	- DIx VIx LEDx VOx		Digital signal to select the active setting group None Digital input Virtual input LED indicator signal Virtual output	Set
Force	Off On		Force flag for status forcing for test purposes. This is a common flag for all stages and output relays, too. Automatically reset by a 5-minute timeout.	Set
Z		ohm	The supervised value scaled to primary value. "Inf" = infinite	
Z		xZn	The supervised value scaled to per unit (pu). $1 \text{ pu} = 1xZ_N = U_{GN}/(\sqrt{3} \times I_{GN})$. "Inf" = infinite	
Z<, Z<<		ohm	Pick-up value scaled to primary value	
Z<, Z<<		xZn	Pick-up setting in per unit (pu). $1 \text{ pu} = 1xZ_N = U_{GN}/(\sqrt{3} \times I_{GN})$.	Set
t<		s	Definite operate time	Set
U1		V	Measured value of positive sequence voltage U_1	
I1		A	Measured value of positive sequence current I_1	

Set = An editable parameter (password needed). C = Can be cleared to zero. F = Editable when force flag is on.

For details of setting ranges, see Table 11.48

Recorded values of the latest eight faults

There are detailed information available of the eight latest earth faults: Time stamp, fault impedance, elapsed delay and setting group.

Table 6.43: Recorded values of the underimpedance stages Z<, Z<< (21)

Parameter	Value	Unit	Description
	yyyy-mm-dd		Time stamp of the recording, date
	hh:mm:ss.ms		Time stamp, time of day
Flt		Zn	Minimum fault impedance
EDly		%	Elapsed time of the operate time setting. 100% = trip
SetGrp	1 2		Active setting group during fault

6.22 Under-excitation protection Q< (40)

Synchronous machines need some minimum level of excitation to remain stable throughout their load range. If excitation is too low, the machine may drop out of synchronism. The under-excitation protection protects the generator against the risk of lost of synchronism.

When the generator produces capacitive power, that is when the reactive component of the power phasor is negative, the excitation current can be so low, that the synchronism is lost.

This stage supervises the amount of capacitive power and in case it exceeds the setting a start signal is issued. If the fault continues longer than user's operation delay time setting, a trip signal is issued.

The measurement of the degree of excitation is based on a complex three-phase power vector, which is calculated from the fundamental components of the phase currents and line-to-line voltages.

Trip area on a PQ-plane

The tripping area of the under-excitation stage on a PQ-plane is defined with two parameters, Q1 and Q2, see Figure 6.46 and Figure 6.47. When the tip of the power phasor lies on the left side of the left side of a straight line drawn through Q1 and Q2 and on the negative side of P-axis, the stage picks up.

The P coordinate of the setting point Q1 has a fixed value equal to zero and the Q coordinate is adjustable.

The P coordinate of the setting point Q2 has a fixed value of 80% of the rated power of the generator and the Q coordinate is adjustable.

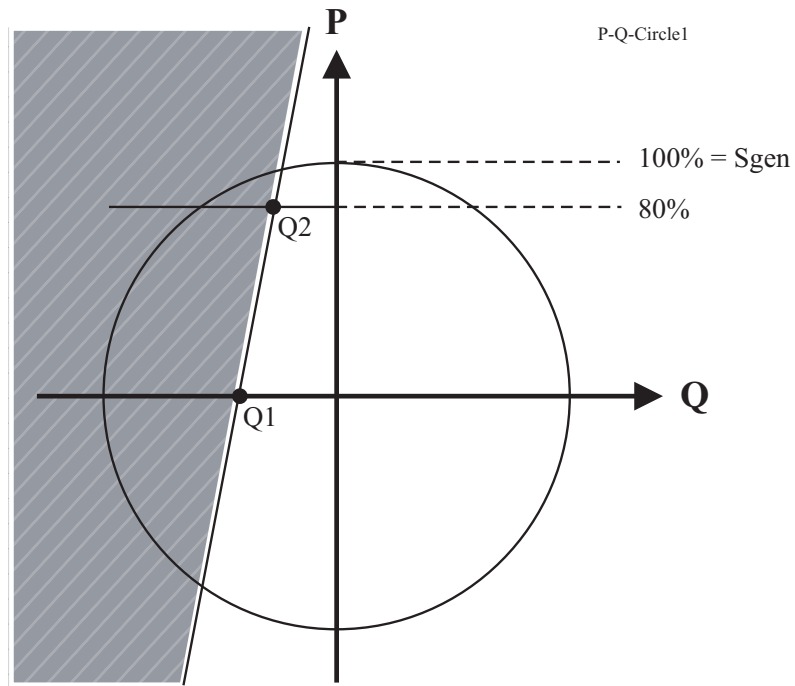

Figure 6.46: Setting of the under-excitation stage by means of the parameters $Q1$ and $Q2$. The shaded area is the area of operation. In this example the operation depends on both P and Q , because the operating line has an 8° slope ($Q1 - Q2 = 14\%$).

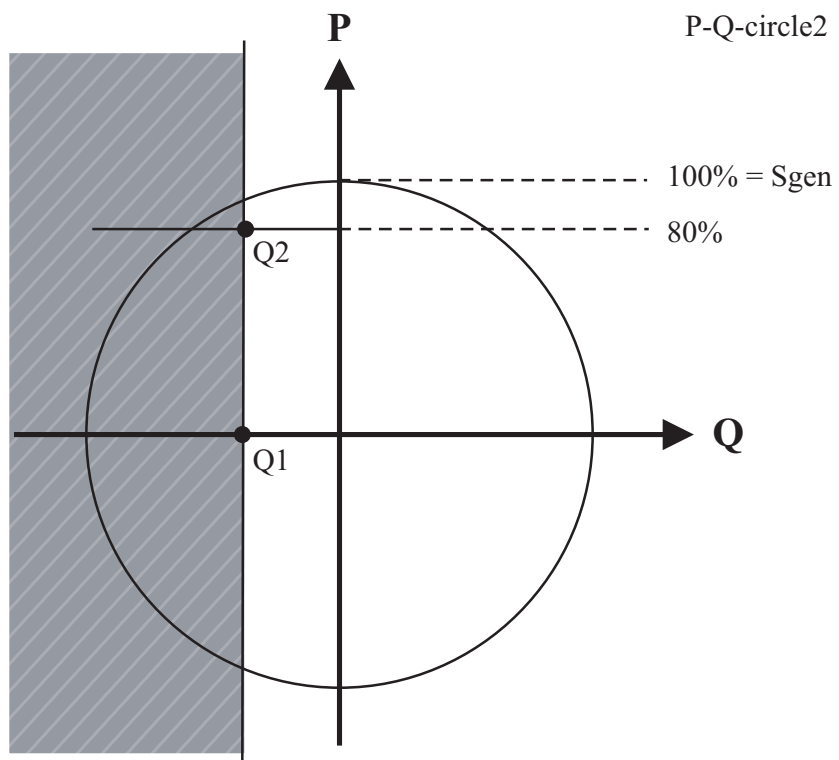

Figure 6.47: Setting of the under-excitation stage by means of the parameters $Q1$ and $Q2$. The shaded area constitutes the area of operation. In the above example the operation solely depends on the reactive power, because the operating line is vertical ($Q1 - Q2 = 0\%$).

Power swing

A release time setting is available against prolonged power swings. In a power swing situation the power phasor is swinging back and forth between capacitive and inductive power. With a long enough release time setting the stage accumulates the total fault time and will eventually trip.

Setting groups

There are two settings groups available. Switching between setting groups can be controlled by digital inputs, virtual inputs (mimic display, communication, logic) and manually.

Table 6.44: Parameters of the under-excitation stage Q< (40)

Parameter	Value	Unit	Description	Note
Status	- Blocked Start Trip		Current status of the stage	 F F
TripTime		s	Estimated time to trip	
SCntr			Cumulative start counter	Clr
TCntr			Cumulative trip counter	Clr
SetGrp	1 or 2		Active setting group	Set
SGrpDI	- DIx VIx LEDx VOx		Digital signal to select the active setting group None Digital input Virtual input LED indicator signal Virtual output	Set
Force	Off On		Force flag for status forcing for test purposes. This is a common flag for all stages and output relays, too. Automatically reset by a 5-minute timeout.	Set
P		%Sgn	The supervised active power value.	
Q		%Sgn	The supervised reactive power value.	
Q@P0%		%Sgn kvar	Setting 1. See Figure 6.46.	Set
Q@P80%		%Sgn kvar	Setting 2. See Figure 6.47.	Set
t<		s	Definite operate time	Set
RIsDly		s	Release delay for power swing	Set

Set = An editable parameter (password needed). C = Can be cleared to zero. F = Editable when force flag is on.

For details of setting ranges, see Table 11.49.

Recorded values of the latest eight faults

There are detailed information available of the eight latest earth faults: Time stamp, fault power P and Q, elapsed delay and setting group.

Table 6.45: Recorded values of the under-excitation stage Q< (40)

Parameter	Value	Unit	Description
	yyyy-mm-dd		Time stamp of the recording, date
	hh:mm:ss.ms		Time stamp, time of day
P		%Sgn	Active fault power
Q		%Sgn	Reactive fault power
EDly		%	Elapsed time of the operate time setting. 100% = trip
SetGrp	1		Active setting group during fault
	2		

6.23 Under-reactance and loss of excitation protection X< (40)

Synchronous machines need some minimum level of excitation to remain stable throughout their load range. If excitation is lost or is too low, the machine may drop out of synchronism. The loss of excitation stages X< and X<<, are used to supervise that the synchronous machine is working in the stable area.

The protection is based on positive sequence impedance as viewed from the machine terminals. This impedance is calculated using the measured three phase voltages and phase currents according the following equation:

Equation 6.7: $Z_1 = \text{positive sequence impedance.}$
 $U_1 = \text{positive sequence voltage phasor}$
 $I_1 = \text{positive sequence current phasor.}$

$$\bar{Z}_1 = \frac{\bar{U}_1}{\bar{I}_1}$$

If this impedance goes under the steady state stability limit, the synchronous machine may lose its stability and drop out of synchronism.

Detecting power swinging

A release time setting is available against prolonged power swings. In a power swing situation the power phasor is swinging back and forth between capacitive and inductive power. With a long enough release time setting the stage accumulates the total fault time and will eventually trip.

Undercurrent blocking

When for some reason voltage collapses but currents remain at normal load levels, the calculated impedance may fall into the trip area. Inverted start signal from the most sensitive overcurrent stage can be used to block the under-reactance stages during abnormal voltages not caused by short circuit faults.

Characteristic on an impedance plane

The characteristic on an impedance plane is a circle covering the unstable area of the synchronous machine (Figure 6.48). The radius $X <$ and centre point [Roffset, Xoffset] of the circle are editable. Whenever the positive sequence impedance goes inside this circle the stage will pick-up. If the fault stays on longer than the definite time delay setting, the stage will issue a trip signal.

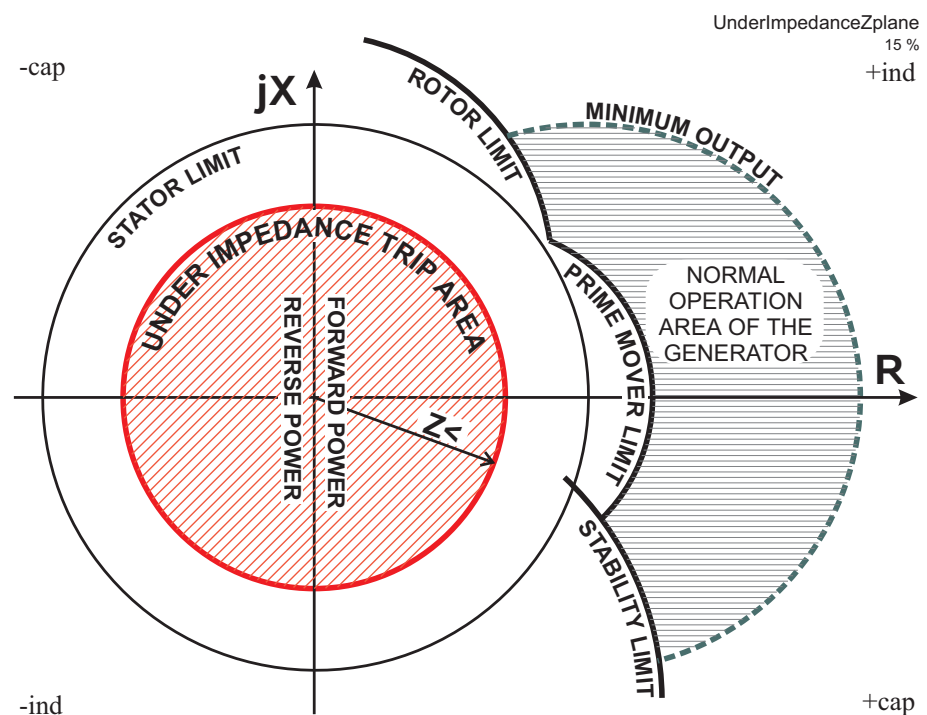

Figure 6.48: The trip region of loss of excitation stage is a circle covering the unstable area of the generator. The radius $X <$, Roffset and Xoffset are the setting parameters. Whenever the positive sequence impedance falls inside the $X <$ circle, the stage picks up.

Calculating setting values

The machine manufacturer specifies:

X_d = synchronous unsaturated reactance and the

X'_d = transient reactance for the synchronous machine.

The settings for loss of excitation stages can be derived from these machine parameters, but there are many practices to do it. Here is one:

Radius of the circle $X < = X_d/2$

Resistive offset $R_{os} = 0.14 (X'_d + X_d/2)$

Reactive offset $X_{os} = -(X'_d + X_d/2)$

All the settings are in per unit.

$$X_{PU} = \frac{X}{Z_N}$$

X_{PU} = Reactance (or resistance) per unit

X = Reactance (or resistance) in ohms

Z_N = Nominal impedance of the machine

$$Z_N = \frac{U_N^2}{S_N}$$

Z_N = Nominal impedance of the machine

U_N = Nominal voltage of the machine

S_N = Nominal power of the machine

Characteristic on power plane

In Figure 6.49 the same characteristics as in the previous figure is drawn on a PQ-power plane assuming a constant voltage of 1 PU. The transformation is $\underline{S} = U^2/Z^*$, where U is the voltage and Z^* is the complex conjugate of impedance Z .

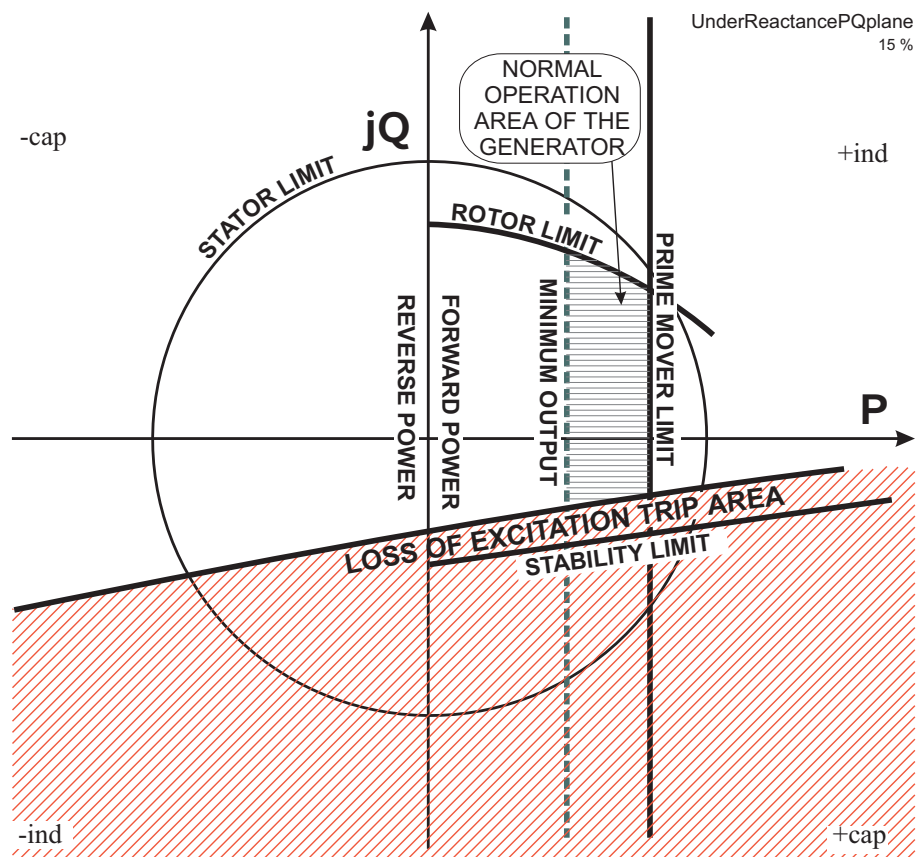

Figure 6.49: The loss of excitation characteristic drawn on a power plane.

Two independent under-reactance stages

There are two separately adjustable stages available: X< and X<<.

Setting groups

There are two settings groups available. Switching between setting groups can be controlled by digital inputs, virtual inputs (mimic display, communication, logic) and manually.

Table 6.46: Parameters of the under-reactance stages X<, X<< (40)

Parameter	Value	Unit	Description	Note
Status	- Blocked Start Trip		Current status of the stage	 F F
TripTime		s	Estimated time to trip	
SCntr			Cumulative start counter	Clr
TCntr			Cumulative trip counter	Clr
SetGrp	1, 2, 3, 4		Active setting group	Set
SGrpDI	- DIx VIx LEDx VOx		Digital signal to select the active setting group None Digital input Virtual input LED indicator signal Virtual output	Set
Force	Off On		Force flag for status forcing for test purposes. This is a common flag for all stages and output relays, too. Automatically reset by a 5-minute timeout.	Set
Z		ohm	The supervised value scaled to primary value. "Inf" = infinite	
Z		xZn	The supervised value scaled to per unit (pu). $1 \text{ pu} = 1xZ_N = U_{GN}/(\sqrt{3} xI_{GN})$. "Inf" = infinite	
Zφ		°	Angle of the supervised impedance	
X<; X<<		ohm	Pick-up value scaled to primary value	
X<; X<<		xZn	Pick-up setting in per unit (pu). $1 \text{ pu} = 1xZ_N = U_{GN}/(\sqrt{3} xI_{GN})$.	Set
t<		s	Definite operate time	Set
RlsDly		s	Release delay	Set
Ros		xZn	Resistive offset for trip area origin in pu.	Set
Xos		xZn	Reactive offset for trip area origin in pu.	Set
Ros		ohm	Resistive offset for trip area origin in primary ohms.	
Xos		xZn	Reactive offset for trip area origin in primary ohms.	

Set = An editable parameter (password needed). C = Can be cleared to zero. F = Editable when force flag is on.

For details of setting ranges, see Table 11.50.

Recorded values of the latest eight faults

There are detailed information available of the eight latest earth faults: Time stamp, fault impedance, fault angle, elapsed delay and setting group.

Table 6.47: Recorded values of the under-reactance stages X<, X<< (40)

Parameter	Value	Unit	Description
	yyyy-mm-dd		Time stamp of the recording, date
	hh:mm:ss.ms		Time stamp, time of day
Flt		Zn	Fault impedance
Angle		°	Fault angle
EDly		%	Elapsed time of the operate time setting. 100% = trip
SetGrp	1, 2, 3, 4		Active setting group during fault

6.24 Reverse power and under-power protection P< (32)

Reverse power function can be used for generators against motoring to protect the prime mover against over-speeding or to disconnect a motor in case the supply voltage is lost and thus prevent any power generation by the motor. Under-power function can be used to detect loss of the mechanical load of a motor.

Reverse and under power function is sensitive to active power. Whenever the active power goes under the pick-up value, the stage picks up and issues a start signal. If the fault situation stays on longer than the delay setting, a trip signal is issued.

Scaling of pick-up setting

The pick-up setting is proportional to the nominal power of the prime mover parameter P_M , which is part of the basic configuration.

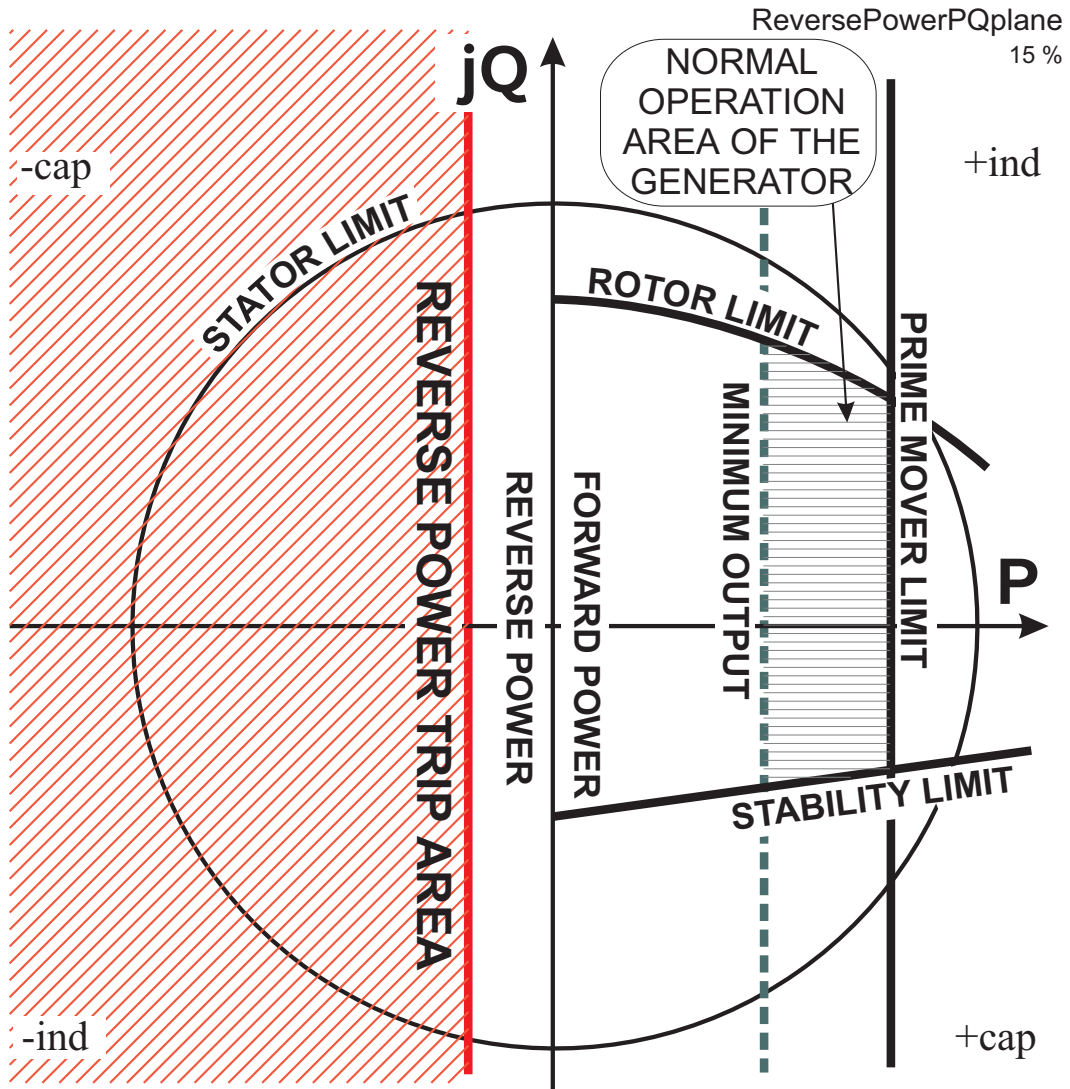

Figure 6.50: Characteristics of reverse power function.

Reverse power

For reverse power protection a negative pick-up value is used (Figure 6.50).

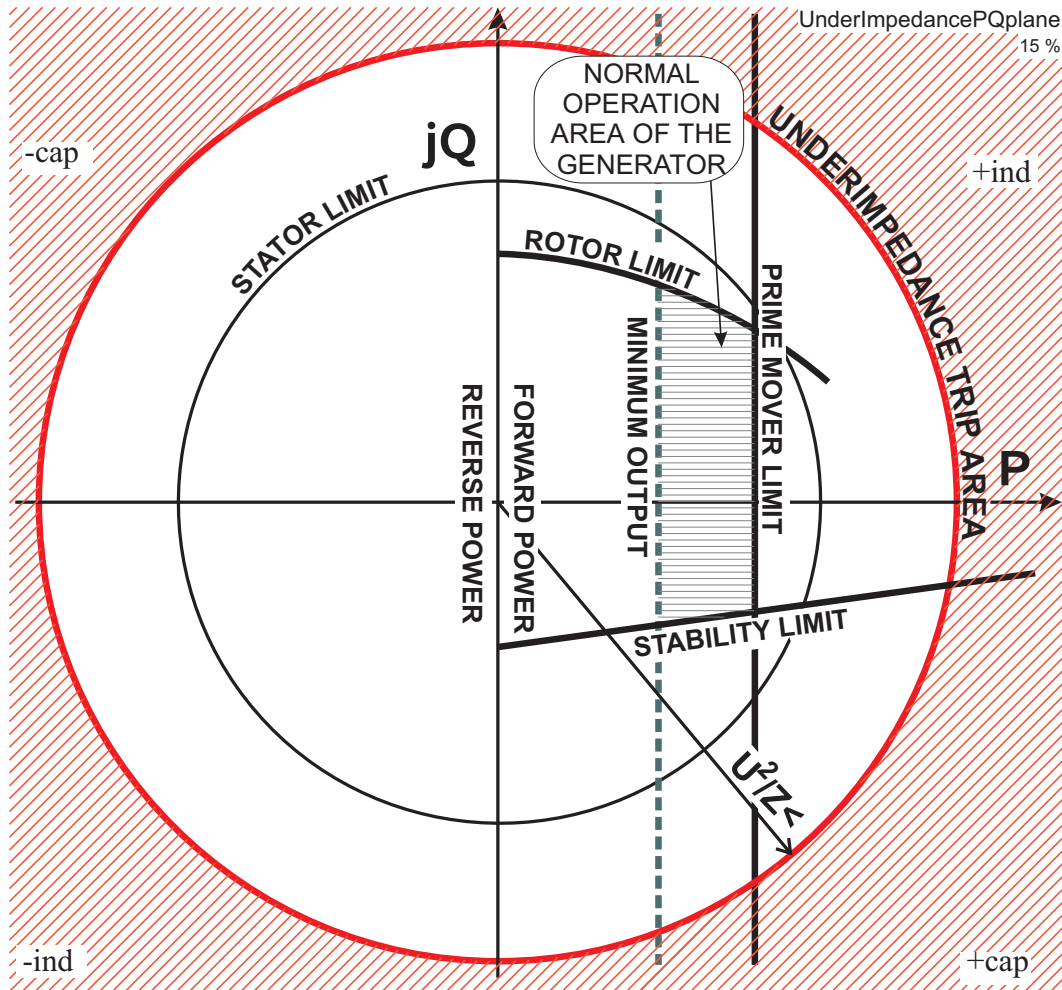

Figure 6.51: Characteristics of under power function.

Under power

When the pick-up value is positive, the function is called under-power (Figure 6.51).

Two independent stages

There are two separately adjustable stages available: P< and P<<.

Setting groups

There are two settings groups available. Switching between setting groups can be controlled by digital inputs, virtual inputs (mimic display, communication, logic) and manually.

There are two identical stages available with independent setting parameters.

Table 6.48: Parameters of the reverse/under power stages P<, P<< (32)

Parameter	Value	Unit	Description	Note
Status	- Blocked Start Trip		Current status of the stage	 F F
SCntr			Cumulative start counter	Clr
TCntr			Cumulative trip counter	Clr
SetGrp	1 or 2		Active setting group	Set
SGrpDI	- DIx VIx LEDx VOx		Digital signal to select the active setting group None Digital input Virtual input LED indicator signal Virtual output	Set
Force	Off On		Force flag for status forcing for test purposes. This is a common flag for all stages and output relays, too. Automatically reset by a 5-minute timeout.	Set
P		kW	The supervised value.	
P<, P<<		kW	Pick-up value scaled to primary value	
P<, P<<		%Pm	Pick-up value scaled to pu	Set
t<, t<<		s	Definite operate time	Set

Set = An editable parameter (password needed). C = Can be cleared to zero. F = Editable when force flag is on.

For details of setting ranges, see Table 11.51.

Recorded values of the latest eight faults

There are detailed information available of the eight latest faults: Time stamp, fault power, elapsed delay and setting group.

Table 6.49: Recorded values of the reverse/under power stages (8 latest faults) P<, P<< (32)

Parameter	Value	Unit	Description
	yyyy-mm-dd		Time stamp of the recording, date
	hh:mm:ss.ms		Time stamp, time of day
Flt		xPm	Minimum power
EDly		%	Elapsed time of the operate time setting. 100% = trip
SetGrp	1 2		Active setting group during fault

6.25 Magnetishing inrush $I_{f2} > (68F2)$

This stage is mainly used to block other stages. The ratio between the second harmonic component and the fundamental frequency component is measured on all the phase currents. When the ratio in any phase exceeds the setting value, the stage gives a start signal. After a settable delay, the stage gives a trip signal.

The start and trip signals can be used for blocking the other stages.

The trip delay is irrelevant if only the start signal is used for blocking.

The trip delay of the stages to be blocked must be more than 60 ms to ensure a proper blocking.

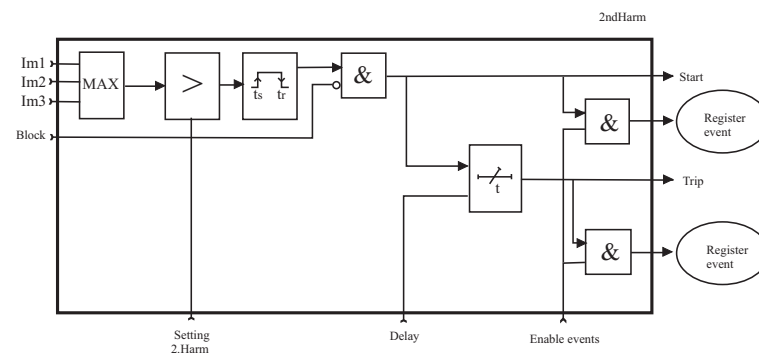

Figure 6.52: Block diagram of the magnetishing inrush stage.

Table 6.50: Setting parameters of magnetishing inrush blocking (68F2)

Parameter	Value	Unit	Default	Description
$I_{f2} >$	10 – 100	%	10	Setting value I_{f2}/I_{fund}
t_{f2}	0.05 – 300.0	s	0.05	Definite operate time
S_On	Enabled; Disabled	-	Enabled	Start on event
S_Off	Enabled; Disabled	-	Enabled	Start off event
T_On	Enabled; Disabled	-	Enabled	Trip on event
T_Off	Enabled; Disabled	-	Enabled	Trip off event

For details of setting ranges, see Table 11.43

Table 6.51: Measured and recorded values of magnetishing inrush blocking (68F2)

	Parameter	Value	Unit	Description
Measured values	IL1H2.		%	2. harmonic of IL1, proportional to the fundamental value of IL1
	IL2H2.		%	2. harmonic of IL2
	IL3H2.		%	2. harmonic of IL3
Recorded values	Flt		%	The max. fault value
	EDly		%	Elapsed time as compared to the set operate time; 100% = tripping

6.26 Transformer over excitation $I_{f5}>$ (68F5)

Overexciting for example a transformer creates odd harmonics. This over excitation stage can be used detect overexcitation. This stage can also be used to block some other stages.

The ratio between the over excitation component and the fundamental frequency component is measured on all the phase currents. When the ratio in any phase exceeds the setting value, the stage gives a start signal. After a settable delay, the stage gives a trip signal.

The trip delay of the stages to be blocked must be more than 60 ms to ensure a proper blocking.

Table 6.52: Setting parameters of over excitation blocking (68F5)

Parameter	Value	Unit	Default	Description
If5>	10 – 100	%	10	Setting value If5/Ifund
t_f5	0.05 – 300.0	s	0.05	Definite operate time
S_On	Enabled; Disabled	-	Enabled	Start on event
S_Off	Enabled; Disabled	-	Enabled	Start off event
T_On	Enabled; Disabled	-	Enabled	Trip on event
T_Off	Enabled; Disabled	-	Enabled	Trip off event

For details of setting ranges, see Table 11.44

Table 6.53: Measured and recorded values of over excitation blocking (68F5)

	Parameter	Value	Unit	Description
Measured values	IL1H5.		%	5. harmonic of IL1, proportional to the fundamental value of IL1
	IL2H5.		%	5. harmonic of IL2
	IL3H5.		%	5. harmonic of IL3
Recorded values	Flt		%	The max. fault value
	EDly		%	Elapsed time as compared to the set operate time; 100% = tripping

6.27 Circuit breaker failure protection CBFP (50BF)

The circuit breaker failure protection can be used to trip any upstream circuit breaker (CB), if the fault has not disappeared within a given time after the initial trip command. A different output contact of the device must be used for this backup trip.

The operation of the circuit-breaker failure protection (CBFP) is based on the supervision of the signal to the selected trip relay and the time the fault remains on after the trip command.

If this time is longer than the operate time of the CBFP stage, the CBFP stage activates another output relay, which will remain activated until the primary trip relay resets.

The CBFP stage is supervising all the protection stages using the same selected trip relay, since it supervises the control signal of this device. See Chapter 5.4.1 Output matrix.

Table 6.54: Parameters of the circuit breaker failure stage CBFP (50BF)

Parameter	Value	Unit	Description	Note
Status	-		Current status of the stage	
	Blocked			
	Start			F
	Trip			F
SCntr			Cumulative start counter	C
TCntr			Cumulative trip counter	C
Force	Off		Force flag for status forcing for test purposes. This is a common flag for all stages and output relays, too. Automatically reset by a 5-minute timeout.	Set
	On			
Cbrelay			The supervised output relay ^{*)} .	Set
	1		Relay T1	
	2		Relay T2	
t>		s	Definite operate time.	Set

^{*)} This setting is used by the circuit breaker condition monitoring, too. See Chapter 7.9 Circuit breaker condition monitoring.

Set = An editable parameter (password needed). C = Can be cleared to zero. F = Editable when force flag is on.

For details of setting ranges, see Table 11.42

Recorded values of the latest eight faults

There are detailed information available of the eight latest faults:
Time stamp and elapsed delay.

Table 6.55: Recorded values of the circuit breaker failure stage (8 latest faults) CBFP (50BF)

Parameter	Value	Unit	Description
	yyyy-mm-dd		Time stamp of the recording, date
	hh:mm:ss.ms		Time stamp, time of day
EDly		%	Elapsed time of the operate time setting. 100% = trip

6.28 Pole slip protection (78)

Dynamic changes in a power system such as a prolonged short-circuits, load jumps or line switching operations may lead to power system oscillations known as a power swing. Power swing manifests itself as regular large fluctuations in currents, voltages and power angle between power system parts.

In a stable power swing situation power oscillations decay and diminish over time in matter of some seconds. After stable power swing synchronism is recaptured and system will reach a new stable equilibrium conditions. Such a stable power swing should not cause a generator or power system part to be separated from the rest of the power system.

In an unstable power swing power oscillations continue to grow eventually causing loss of synchronism or pole slipping. Pole slipping situation can result very quickly generator overloading and damages. When generator is working out of step, or pole slipping, generator is alternatively producing generating and motoring action in cycle of some seconds. This oscillation between generating and motoring mode causes high mechanical stress to generator and prime mover and also high electrical overload. Unstable operation conditions may also cause propagation of disturbances in the power system leading to possible widespread outages. A generator under out-of-step condition must be separated from the rest of power system.

Generator may pole slip due to various reasons. A few most obvious reasons are: The prime mover or governor failure, the failure in generator operating close to its stability limits, prolonged clearance of low-impedance fault, generator unsynchronized connection to a power system, any disturbance from network switching action.

Pole slip protection principle

A common method to implement pole slipping protection is to measure apparent impedance in generator or block transformer terminals and track impedance vector trajectory in RX-plane. Apparent generator impedance measured on generator terminals (Point A) will vary as function of power angle and ratio of generator and power system voltages. Apparent impedance is plotted on RX-plane a characteristic set of impedance loci are shown. Decision

to separate the generator from the power system is based on actual course of impedance vectors (loci) on RX-plane.

As pole slipping is essentially symmetrical phenomena the apparent impedances are calculated from the positive sequences fundamental frequency components of the voltages and currents.

A common practice to illustrate pole slipping is to use simplified two machine model. The following diagram shows the generator, power network and equivalent voltages \underline{U}_G and \underline{U}_N . The generator, power network and possible transformer impedances lie between these two sources. Total system impedance Z_{tot} is sum of component impedances Z_G , Z_{TR} and Z_N .

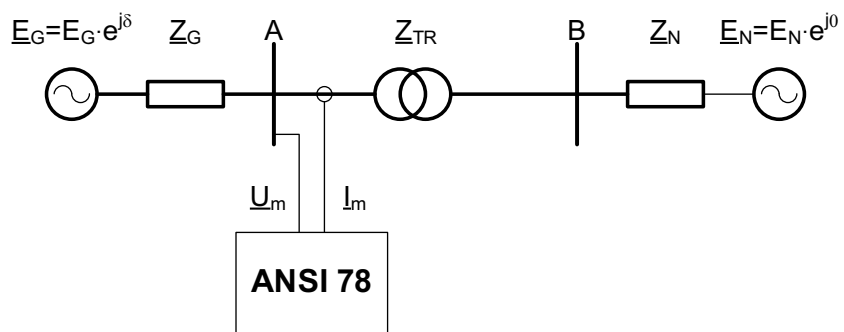

Figure 6.53: Two machine model of power swing

The following equations apply on location A:

Equation 6.8: Total impedance

$$\underline{Z}_{tot} = \underline{Z}_G + \underline{Z}_{TR} + \underline{Z}_N$$

Equation 6.9: Measured current, independent of location

$$\underline{I}_m = \underline{I} = \frac{\underline{E}_G - \underline{E}_N}{\underline{Z}_{tot}}$$

Equation 6.10: Measured voltage at location A

$$\underline{U}_m = \underline{E}_G - \underline{Z}_G \cdot \underline{I}$$

Equation 6.11: Measured apparent impedance

$$\underline{Z}_m = \frac{\underline{U}_m}{\underline{I}}$$

Substitute Equation 6.9 and Equation 6.10 in Equation 6.11

Equation 6.12:

$$\underline{Z}_m = \frac{\underline{E}_G}{\underline{E}_G - \underline{E}_N} \cdot \underline{Z}_{tot} - \underline{Z}_G = \frac{\underline{Z}_{tot}}{1 - \frac{\underline{E}_N}{\underline{E}_G}} - \underline{Z}_G$$

As $\underline{E}_G = E_G \cdot e^{-j\delta}$ and $\underline{E}_N = E_N \cdot e^{-j0} = E_N$, Equation 6.12 will become as

Equation 6.13:

$$\underline{Z}_m = \frac{\underline{Z}_{tot}}{1 - \frac{E_N}{E_G} \cdot e^{j\delta}} - \underline{Z}_G$$

Equation 6.13 represents impedance behavior of two machine model in pole slipping condition. Plotting impedances on RX-plane as function of power angle δ and voltage ratio E_N/E_G will give a set of impedance loci representing apparent impedance behavior with given power angle δ and voltage ratio E_N/E_G .

In stable operation conditions power angle δ depends of generator load and it is essentially constant. In stable operation conditions power angle δ varies between 30° and 60° depending on generator load. During pole slipping power angle δ can vary between 0° and 360° therefore impedance behavior according Equation 6.13 should be plotted with power angle ranging from 0° to 360° . While plotting impedance loci voltage ratio E_N/E_G is assumed to be constant during the pole slip resulting circular impedance loci.

The figure below represents general concept of apparent impedance behavior during the pole slip.

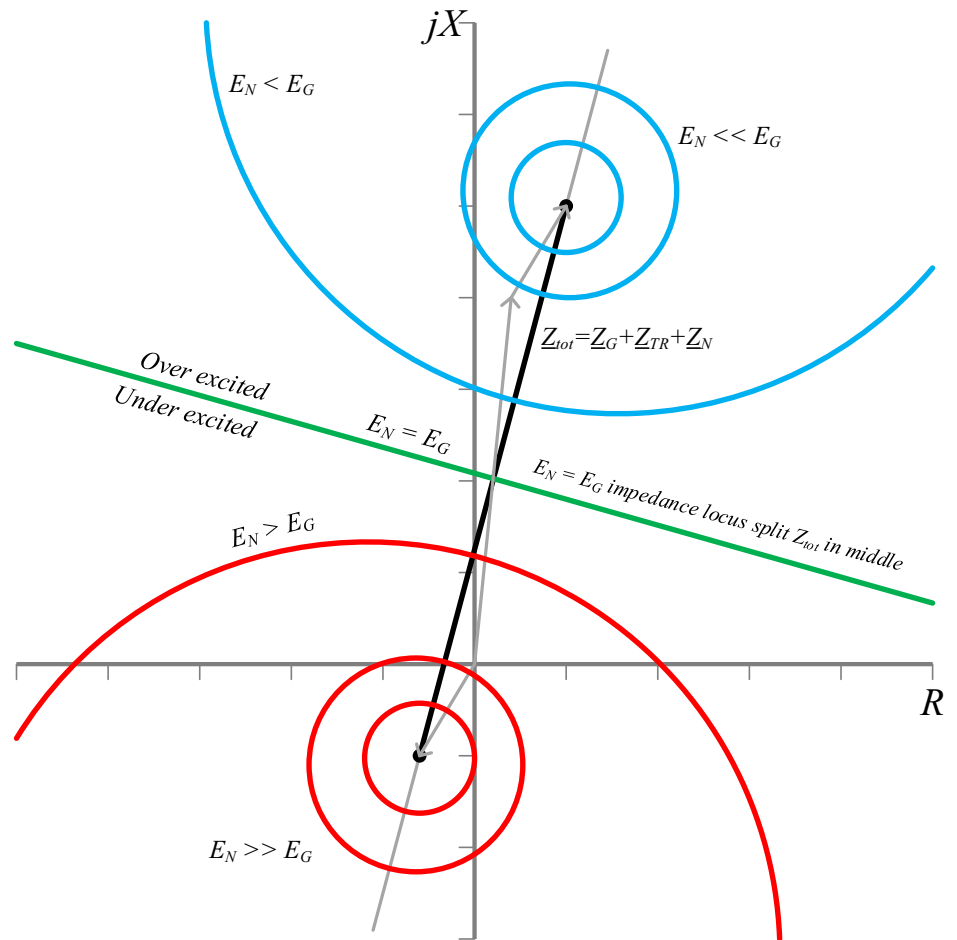

Figure 6.54: Pole slipping impedance loci

Protection settings

Pole slip protection stage has rectangular power swing detection characteristics that is set by forward and reverse R and X. Setting values are given as relative to generator nominal impedance. As measured apparent impedance locus passes the set power swing characteristics the pole slip is detected and count. The pole slip is counted only if positive sequence current exceeds minimum threshold value.

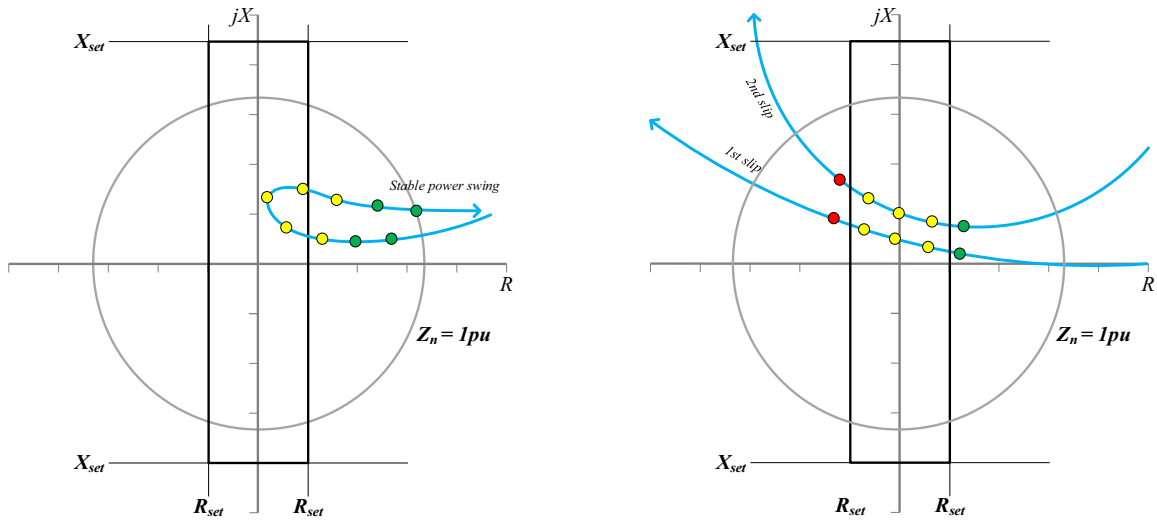

Figure 6.55: Stable and unstable power swing (pole slip) in reference to detection characteristics

The first detected pole slip starts stage counter. If required number of the pole slips occurs within the set time window stage trips. Tripping pulse has fixed length of 100ms. Figure below shows stage starting and tripping actions.

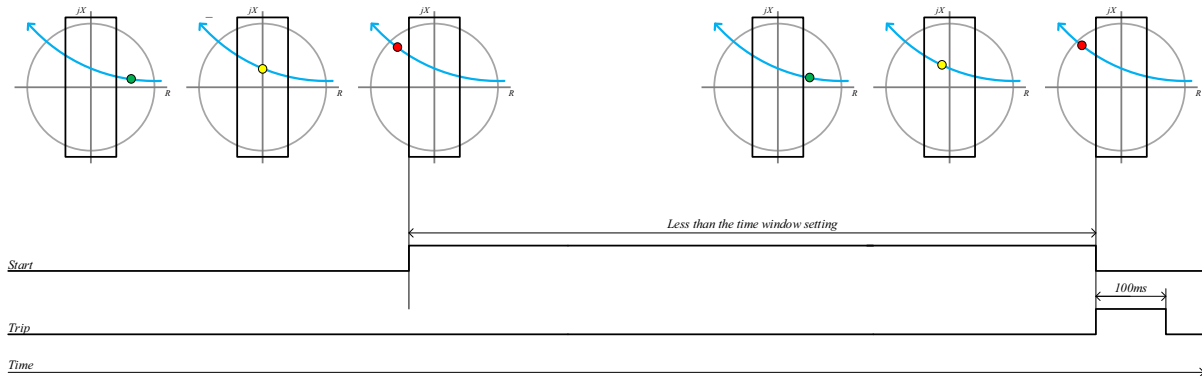

Figure 6.56: Pole slip protection stage starting and tripping

Finding out settings

Plotting Equation 6.13 in RX-plane when $E_N = E_G$ and adding total impedance line Z_{tot} together two lines connecting swing center line and both source impedances gives a graphical presentation of E_N/E_G ratio and power angle δ . This graphical presentation is a great aid in order to determine out-of-step stage setting.

The figure below shows impedance swing locus, source impedances connected with total impedance vector Z_{tot} and three points on swing trajectory representing three different generator operating conditions.

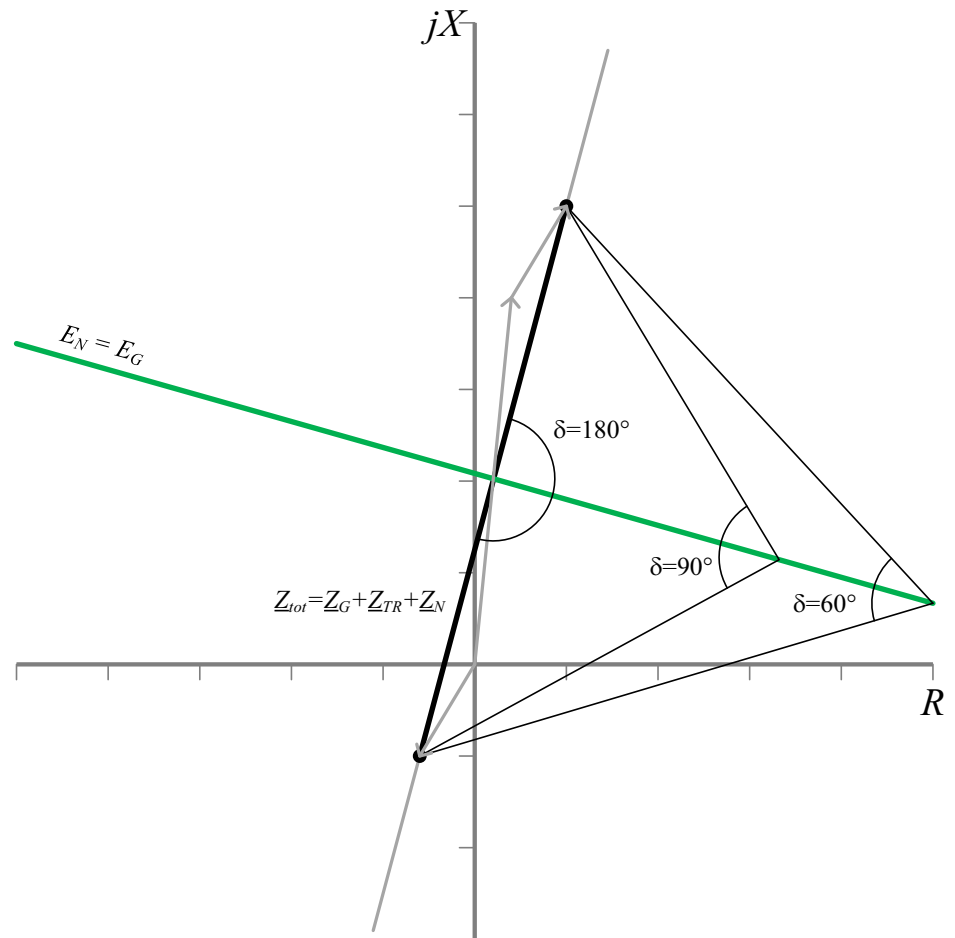

Figure 6.57: Total impedance line and swing center line in RX-plane

The right most operating point identifies operating point when power angle $\delta=60^\circ$. This can be considered to be within in acceptable power angle range therefore stage setting should rule out this operating point.

The operating point $\delta=90^\circ$ is stability limit of two machine model shown in Figure 6.53. Setting R_{set} according to $\delta=90^\circ$ is good candidate for the setting point. In order to have some safety margin somewhat bigger power angle δ can be selected.

The last operating point in Figure 6.57 indicates moment of E_N and E_G phase reversal. Initiating circuit breaker trip commend when E_N and E_G are in phase reversal result CB opening in moment of highest load. This should be avoided.

Reactance setting of the stage are done in accordance of source reactance and transformer and line reactance. In pole slipping conditions generator synchronous impedance X_d is not valid but transient impedance X'_d should be used. In source direction reactance setting of $2X'_d$ can be used and in line direction setting value can be set in range of $1 - 1.5 \times X_{\text{TR}}$. The figure below show setting values for out-of-step stage.

Pole slip frequency is characteristic property of the power system that is determined by generator torque and inertia. Slip frequency can't be determined analytically but utilizing transient stability studies. The slip frequency is not constant. From protection point of view, the start of pole slipping is the most important moment. At the first moment of unstable power swing slipping frequency may be in range of 0.5Hz to 2.5Hz.

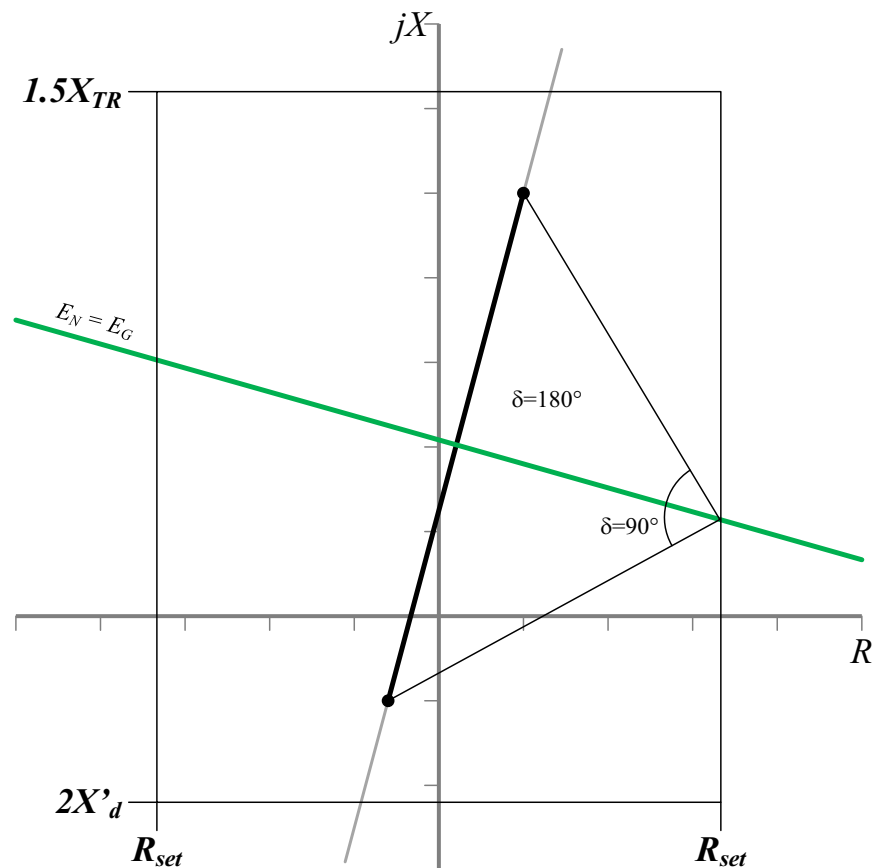

Figure 6.58: Pole slip stage setting principles

Setting groups

There are four settings groups available for each stage. Switching between setting groups can be controlled by digital inputs, virtual inputs (mimic display, communication, logic) and manually. See Chapter 6.2 General features of protection stages for more details.

Table 6.56: Parameters of the out-of-step (pole slip) stage (78)

Parameter	Value	Unit	Description	Note
Status	-		Current status of the stage	
	Blocked			
	Trip			F
SCntr			Cumulative start counter	C

Parameter	Value	Unit	Description	Note
TCntr			Cumulative trip counter	C
SetGrp	1 or 2		Active setting group	Set
SGrpDI			Digital signal to select the active setting group	Set
	-		None	
	DIx		Digital input	
	VIx		Virtual input	
	LEDx		LED indicator signal	
	VOx		Virtual output	
	Fx		Function key	
Group	1, 2, 3 or 4		Active setting group	Set
R setting forward		xZn	Pole slip detection area forward R limit	Set
R setting reverse		xZn	Pole slip detection area reverse R limit	Set
X setting forward		xZn	Pole slip detection area forward X limit	Set
X setting reverse		xZn	Pole slip detection area reverse X limit	Set
I1 min setting		xIn	Positive sequence current threshold limit	Set
Number of pole slips			Number of pole slips to trip	Set
Time window		s	Time window to detect required amount of slips	Set

Set = An editable parameter (password needed). C = Can be cleared to zero. F = Editable when force flag is on.

For details of setting ranges, see Table 11.52

Recorded values of the latest eight faults

There are detailed information available of the eight latest faults: Time stamp, fault type, fault current, load current before the fault, elapsed delay and setting group.

Table 6.57: Recorded values of the out-of-step (pole slip) stage (78)

Parameter	Value	Unit	Description
	yyyy-mm-dd		Time stamp of the recording, date
	hh:mm:ss.ms		Time stamp, time of day
Group	1, 2, 3 or 4		Active setting group during the fault
I1 fault value		xIn	Positive sequence current during the fault
U1 fault value		xUn	Positive sequence voltage during the fault
Pole slips			Number of pole slips during the fault
Fault type	Mot/Gen		Pole slip direction
Elapsed time	0 – 100	%	Elapsed time of the time window setting.

6.29 Cold load pick-up and magnetising inrush

Cold load pick-up

A situation is regarded as cold load when all the three phase currents have been less than a given idle value and then at least one of the currents exceeds a given pick-up level within 80 ms. In such case the cold load detection signal is activated for the time set as **Maximum time** or until the measured signal returns below the value set as **Pickup current**. This signal is available for output matrix and blocking matrix. Using virtual outputs of the output matrix setting group control is possible.

Application for cold load detection

Right after closing a circuit breaker a given amount of overload can be allowed for a given limited time to take care of concurrent thermostat controlled loads. Cold load pick-up function does this for example by selecting a more coarse setting group for over-current stage(s). It is also possible to use the cold load detection signal to block any set of protection stages for a given time.

Magnetising inrush detection

Magnetising inrush detection is quite similar with the cold load detection but it does also include a condition for second harmonic relative content of the currents. When all phase currents have been less than a given idle value and then at least one of them exceeds a given pick-up level within 80 ms and the ratio 2nd harmonic ratio to fundamental frequency, I_{f2}/I_{f1} , of at least one phase exceeds the given setting, the inrush detection signal is activated. This signal is available for output matrix and blocking matrix. Using virtual outputs of the output matrix setting group control is possible.

By setting the 2nd harmonic pickup parameter for I_{f2}/I_{f1} to zero, the inrush signal will behave equally with the cold load pick-up signal.

Application for inrush current detection

The inrush current of transformers usually exceeds the pick-up setting of sensitive overcurrent stages and contains a lot of even harmonics. Right after closing a circuit breaker the pick-up and tripping of sensitive overcurrent stages can be avoided by selecting a more coarse setting group for the appropriate over-current stage with inrush detect signal. It is also possible to use the detection signal to block any set of protection stages for a given time.

NOTE: Inrush detection is based on FFT - calculation which requires full cycle of data for analyzing the harmonic content. Therefore when using inrush blocking function the cold load pick up starting conditions are used for activating the inrush blocking when the current rise is noticed. If in the signal is found a significant ratio of second harmonic component after 1st cycle the blocking is continued, otherwise 2nd harmonic based blocking signal is released. Inrush blocking is recommended to be used into time delayed overcurrent stages while non blocked instant overcurrent stage is set to 20 % higher than expected inrush current. By this scheme fast reaction time in short circuit faults during the energization can be achieved while time delayed stages are blocked by inrush function.

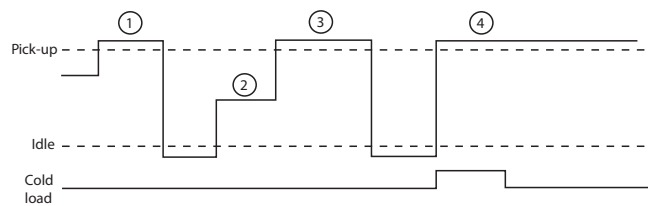

1. No activation because the current has not been under the set I_{DLE} current.
2. Current dropped under the I_{DLE} current level but now it stays between the I_{DLE} current and the pick-up current for over 80ms.
3. No activation because the phase two lasted longer than 80ms.
4. Now we have a cold load activation which lasts as long as the operate time was set or as long as the current stays above the pick-up setting.

Figure 6.59: Functionality of cold load / inrush current feature.

Table 6.58: Parameters of the cold load & inrush detection function

Parameter	Value	Unit	Description	Note
ColdLd	-		Status of cold load detection:	
	Start		Cold load situation is active	
	Trip		Timeout	
Inrush	-		Status of inrush detection:	
	Start		Inrush is detected	
	Trip		Timeout	
ILmax		A	The supervised value. Max. of IL1, IL2 and IL3	
Pickup		A	Primary scaled pick-up value	
Idle		A	Primary scaled upper limit for idle current	
MaxTime		s		Set
Idle		xI_{MODE}	Current limit setting for idle situation	Set
Pickup		xI_{mode}	Pick-up setting for minimum start current	Set
	80	ms	Maximum transition time for start recognition	

Parameter	Value	Unit	Description	Note
Pickupf2		%	Pick-up value for relative amount of 2nd harmonic, I_{f2}/I_{f1}	Set

Set = An editable parameter (password needed).

For details of setting ranges, see Table 11.55

6.30 Programmable stages (99)

For special applications the user can built own protection stages by selecting the supervised signal and the comparison mode.

The following parameters are available:

- **Priority**
If operate times less than 80 milliseconds are needed select 10 ms. For operate times under one second 20 ms is recommended. For longer operate times and THD signals 100 ms is recommended.
- **Coupling A**
The name of the supervised signal in “>” and “<” modes (see table below). Also the name of the supervised signal 1 in “Diff” and “AbsDiff” modes.
- **Coupling B**
The name of the supervised signal 2 in “Diff” and “AbsDiff” modes.
- **Compare condition**
Compare mode. ‘>’ for over or ‘<’ for under comparison, “Diff” and “AbsDiff” for comparing Coupling A and Coupling B.
- **Pick-up**
Limit of the stage. The available setting range and the unit depend on the selected signal.
- **Operation delay**
Definite time operation delay
- **Hysteresis**
Dead band (hysteresis)
- **No Compare limit for mode <**
Only used with compare mode under (‘<’). This is the limit to start the comparison. Signal values under NoCmp are not regarded as fault.

Table 6.59: Available signals to be supervised by the programmable stages

IL1, IL2, IL3	Phase currents
Io	Residual current input
U12, U23, U31	Line-to-line voltages
UL1, UL2, UL3	Phase-to-ground voltages
Uo	Zero sequence voltage

f	Frequency
P	Active power
Q	Reactive power
S	Apparent power
Cos Fii	Cosine φ
IoCalc	Phasor sum $I_{L1} + I_{L2} + I_{L3}$
I1	Positive sequence current
I2	Negative sequence current
I2/I1	Relative negative sequence current
I2/In	Negative sequence current in pu
U1	Positive sequence voltage
U2	Negative sequence voltage
U2/U1	Relative negative sequence voltage
IL	Average $(I_{L1} + I_{L2} + I_{L3}) / 3$
TanFii	Tangent φ [= $\tan(\arccos\varphi)$]
Prms	Active power rms value
Qrms	Reactive power rms value
Srms	Apparent powre rms value
THDIL1	Total harmonic distortion of I_{L1}
THDIL2	Total harmonic distortion of I_{L2}
THDIL3	Total harmonic distortion of I_{L3}
THDUa	Total harmonic distortion of input U_A
THDUb	Total harmonic distortion of input U_B
THDUc	Total harmonic distortion of input U_C
fy	Frequency behind circuit breaker
fz	Frequency behind 2nd circuit breaker
IL1RMS	IL1 RMS for average sampling
IL2RMS	IL2 RMS for average sampling
IL3RMS	IL3 RMS for average sampling
ILmin, ILmax	Minimum and maximum of phase currents
ULLmin, ULLmax	Minimum and maximum of line voltages
ULNmin, ULNmax	Minimum and maximum of phase voltages
VAI1, VAI2, VAI3, VAI4, VAI5	Virtual analog inputs 1, 2, 3, 4, 5 (GOOSE)

Signals available depending on slot 8 options.

Eight independent stages

The device has eight independent programmable stages. Each programmable stage can be enabled or disabled to fit the intended application.

Setting groups

There are four settings groups available. Switching between setting groups can be controlled by digital inputs, virtual inputs (mimic display, communication, logic) and manually.

There are four identical stages available with independent setting parameters.

See Chapter 6.2 General features of protection stages for more details.

Table 6.60: Parameters of the programmable stages PrgN (99)

Parameter	Value	Unit	Description	Note
Status	-		Current status of the stage	
	Blocked			
	Start			F
	Trip			F
SCntr			Cumulative start counter	C
TCntr			Cumulative trip counter	C
SetGrp	1, 2, 3, 4		Active setting group	Set
SGrpDI			Digital signal to select the active setting group	Set
	-		None	
	DIx		Digital input	
	VIx		Virtual input	
	LEDx		LED indicator signal	
	VOx		Virtual output	
	Fx		Function key	
Force	Off		Force flag for status forcing for test purposes. This is a common flag for all stages and output relays, too. Automatically reset by a 5-minute timeout.	Set
	On			
Link	See Table 6.59		Name for the supervised signal	Set
See Table 6.59			Value of the supervised signal	
Cmp			Mode of comparison	Set
	>		Over protection	
	<		Under protection	
	Diff		Difference	
	AbsDiff		Absolut difference	
Pickup			Pick up value scaled to primary level	
Pickup		pu	Pick up setting in pu	Set
t		s	Definite operate time	Set
Hyster		%	Dead band setting	Set
NoCmp		pu	Minimum value to start under comparison. (Mode='<')	Set

Set = An editable parameter (password needed). C = Can be cleared to zero. F = Editable when force flag is on.

Recorded values of the latest eight faults

There is detailed information available of the eight latest faults: Time stamp, fault value and elapsed delay.

Table 6.61: Recorded values of the programmable stages PrgN (99)

Parameter	Value	Unit	Description
	yyyy-mm-dd		Time stamp of the recording, date
	hh:mm:ss.ms		Time stamp, time of day
Flt		pu	Fault value
EDly		%	Elapsed time of the operate time setting. 100% = trip
SetGrp	1, 2, 3, 4		Active setting group during fault

6.31 Inverse time operation

The inverse time operation - i.e. inverse definite minimum time (IDMT) type of operation - is available for several protection functions. The common principle, formulae and graphic representations of the available inverse delay types are described in this chapter.

Inverse delay means that the operate time depends on the measured real time process values during a fault. For example with an overcurrent stage using inverse delay a bigger a fault current gives faster operation. The alternative to inverse delay is definite delay. With definite delay a preset time is used and the operate time does not depend on the size of a fault.

Stage specific inverse delay

Some protection functions have their own specific type of inverse delay. Details of these dedicated inverse delays are described with the appropriate protection function.

Operation modes

There are three operation modes to use the inverse time characteristics:

- Standard delays
Using standard delay characteristics by selecting a curve family (IEC, IEEE, IEEE2, RI) and a delay type (Normal inverse, Very inverse etc). See Chapter 6.31.1 Standard inverse delays IEC, IEEE, IEEE2, RI.
- Standard delay formulae with free parameters
selecting a curve family (IEC, IEEE, IEEE2) and defining one's own parameters for the selected delay formula. This mode is activated by setting delay type to 'Parameters', and then editing the delay function parameters A – E. See Chapter 6.31.2 Free parameterization using IEC, IEEE and IEEE2 equations.
- Fully programmable inverse delay characteristics

Building the characteristics by setting 16 [current, time] points. The relay interpolates the values between given points with 2nd degree polynomials. This mode is activated by setting curve family to 'PrgN'. There are maximum three different programmable curves available at the same time. Each programmed curve can be used by any number of protection stages. See Chapter 6.31.3 Programmable inverse time curves.

Local panel graph

The device will show a graph of the currently used inverse delay on the local panel display. Up and down keys can be used for zooming. Also the delays at $20 \times I_{SET}$, $4 \times I_{SET}$ and $2 \times I_{SET}$ are shown.

Inverse time setting error signal

If there are any errors in the inverse delay configuration the appropriate protection stage will use definite time delay.

There is a signal 'Setting Error' available in output matrix, which indicates three different situations:

1. Settings are currently changed with VAMPSET or local panel, and there is temporarily an illegal combination of curve/delay/points. For example if previous settings were IEC/NI and then curve family is changed to IEEE, the setting error will be active, because there is no NI type available for IEEE curves. After changing valid delay type for IEEE mode (for example MI), the 'Setting Error' signal will release.
2. There are errors in formula parameters A – E, and the device is not able to build the delay curve
3. There are errors in the programmable curve configuration and the device is not able to interpolate values between the given points.

Limitations

The maximum measured secondary phase current is $50 \times I_N$ and the maximum directly measured earth fault current is $10 \times I_{0N}$ for residual current input. The full scope of inverse delay curves goes up to 20 times the setting. At high setting the maximum measurement capability limits the scope of inverse curves according to the following table.

Current input	Maximum measured secondary current	Maximum secondary scaled setting enabling inverse delay times up to full 20x setting
I_{L1} , I_{L2} , I_{L3} and I_{0Calc}	250 A	12.5 A
$I_{01} = 5$ A	50 A	2.5 A
$I_{01} = 1$ A	10 A	0.5 A
$I_{01} = 0.2$ A	2 A	0.1 A

1. Example of limitation

$$CT = 750 / 5$$

$$CT_0 = 100 / 1 \text{ (cable CT is used for residual current)}$$

The CT_0 is connected to a 1 A terminals of input I_{01} .

For overcurrent stage $I>$ the table above gives 12.5 A. Thus the maximum setting for $I>$ stage giving full inverse delay range is $12.5 \text{ A} / 5 \text{ A} = 2.5 \times I_N = 1875 \text{ A}_{\text{Primary}}$.

For earth fault stage $I_0>$ the table above gives 0.5 A. Thus the maximum setting for $I_0>$ stage giving full inverse delay range is $0.5 \text{ A} / 1 \text{ A} = 0.5 \times I_{0N} = 50 \text{ A}_{\text{Primary}}$.

2. Example of limitation

$$CT = 750 / 5$$

Application mode is Motor

Rated current of the motor = 600 A

$I_{0\text{Calc}}$ ($= I_{L1} + I_{L2} + I_{L3}$) is used for residual current

At secondary level the rated motor current is $600 / 750 \times 5 = 4 \text{ A}$

For overcurrent stage $I>$ the table above gives 12.5 A. Thus the maximum setting giving full inverse delay range is $12.5 \text{ A} / 4 \text{ A} = 3.13 \times I_{\text{MOT}} = 1875 \text{ A}_{\text{Primary}}$.

For earth fault stage $I_0>$ the table above gives 12.5 A. Thus the maximum setting for $I_0>$ stage giving full inverse delay range is $12.5 \text{ A} / 5 \text{ A} = 2.5 \times I_{0N} = 1875 \text{ A}_{\text{Primary}}$.

6.31.1**Standard inverse delays IEC, IEEE, IEEE2, RI**

The available standard inverse delays are divided in four categories IEC, IEEE, IEEE2 and RI called delay curve families. Each category of family contains a set of different delay types according the following table.

Inverse time setting error signal

The inverse time setting error signal will be activated, if the delay category is changed and the old delay type doesn't exist in the new category. See Chapter 6.31 Inverse time operation for more details.

Limitations

The minimum definite time delay start latest, when the measured value is twenty times the setting. However, there are limitations at high setting values due to the measurement range. Chapter 6.31 Inverse time operation for more details.

Table 6.62: Available standard delay families and the available delay types within each family.

Delay type		Curve family				
		DT	IEC	IEEE	IEEE2	RI
DT	Definite time	X				
NI	Normal inverse		X		X	
VI	Very inverse		X	X	X	
EI	Extremely inverse		X	X	X	
LTI	Long time inverse		X	X		
LTEI	Long time extremely inverse			X		
LTVI	Long time very inverse			X		
MI	Moderately inverse			X	X	
STI	Short time inverse			X		
STEI	Short time extremely inverse			X		
RI	Old ASEA type					X
RXIDG	Old ASEA type					X

IEC inverse time operation

The operate time depends on the measured value and other parameters according Equation 6.14. Actually this equation can only be used to draw graphs or when the measured value I is constant during the fault. A modified version is implemented in the relay for real time usage.

t = Operation delay in seconds

k = User's multiplier

I = Measured value

I_{PICKUP} = User's pick up setting

A, B = Constants parameters according Table 6.63.

Equation 6.14:

$$t = \frac{k A}{\left(\frac{I}{I_{START}}\right)^B - 1}$$

There are three different delay types according IEC 60255-3, Normal inverse (NI), Extremely inverse (EI), Very inverse (VI) and a VI extension. Additional there is a de facto standard Long time inverse (LTI).

Table 6.63: Constants for IEC inverse delay equation

Delay type		Parameter	
		A	B
NI	Normal inverse	0.14	0.02
EI	Extremely inverse	80	2
VI	Very inverse	13.5	1
LTI	Long time inverse	120	1

Example for Delay type "Normal inverse (NI)":

$k = 0.50$

$I = 4 \text{ pu}$ (constant current)

$I_{\text{PICKUP}} = 2 \text{ pu}$

$A = 0.14$

$B = 0.02$

$$t = \frac{0.50 \cdot 0.14}{\left(\frac{4}{2}\right)^{0.02} - 1} = 5.0$$

The operate time in this example will be 5 seconds. The same result can be read from Figure 6.60.

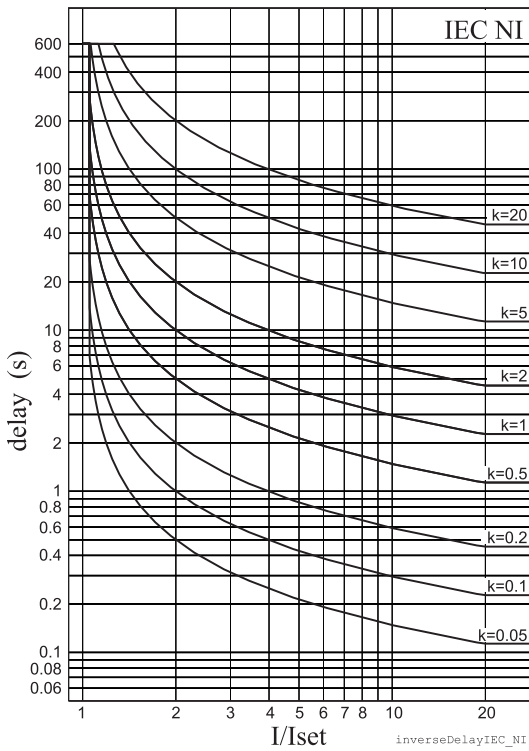

Figure 6.60: IEC normal inverse delay.

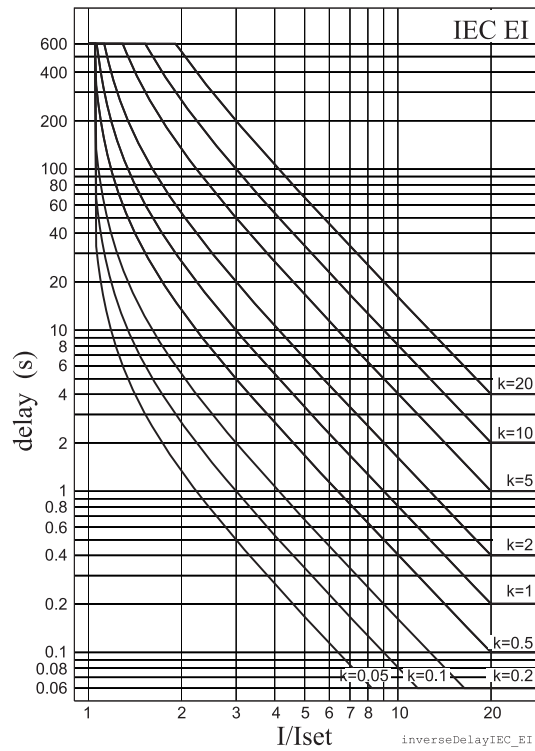

Figure 6.61: IEC extremely inverse delay.

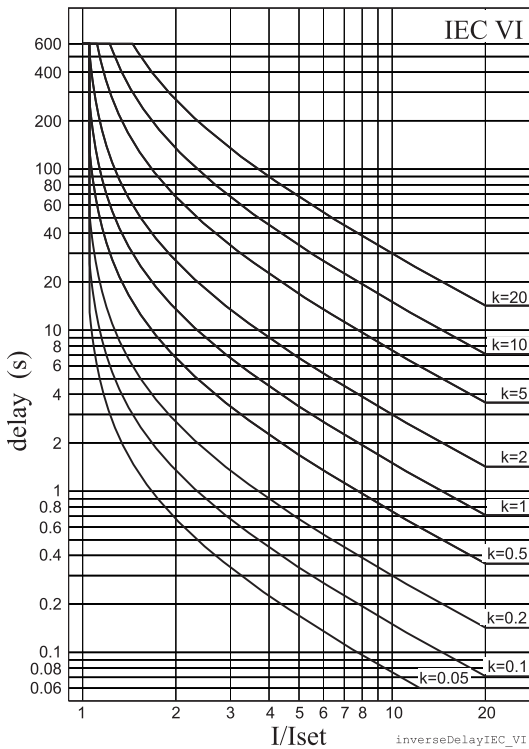

Figure 6.62: IEC very inverse delay.

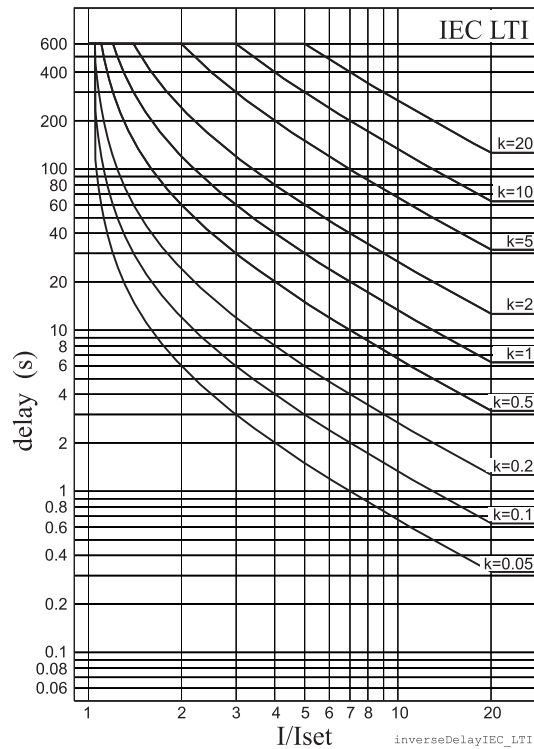

Figure 6.63: IEC long time inverse delay.

IEEE/ANSI inverse time operation

There are three different delay types according IEEE Std C37.112-1996 (MI, VI, EI) and many de facto versions according Table 6.64. The IEEE standard defines inverse delay for both trip and release operations. However, in the VAMP relay only the trip time is inverse according the standard but the release time is constant.

The operation delay depends on the measured value and other parameters according Equation 6.15. Actually this equation can only be used to draw graphs or when the measured value I is constant during the fault. A modified version is implemented in the relay for real time usage.

Equation 6.15:

$$t = k \left[\frac{A}{\left(\frac{I}{I_{START}} \right)^C} + B \right]$$

t = Operation delay in seconds

k = User's multiplier

I = Measured value

I_{PICKUP} = User's pick up setting

A,B,C = Constant parameter according Table 6.64.

Table 6.64: Constants for IEEE/ANSI inverse delay equation

Delay type		Parameter		
		A	B	C
LTI	Long time inverse	0.086	0.185	0.02
LTVI	Long time very inverse	28.55	0.712	2
LTEI	Long time extremely inverse	64.07	0.250	2
MI	Moderately inverse	0.0515	0.1140	0.02
VI	Very inverse	19.61	0.491	2
EI	Extremely inverse	28.2	0.1217	2
STI	Short time inverse	0.16758	0.11858	0.02
STEI	Short time extremely inverse	1.281	0.005	2

Example for Delay type "Moderately inverse (MI)":

$$k = 0.50$$

$$I = 4 \text{ pu}$$

$$I_{\text{PICKUP}} = 2 \text{ pu}$$

$$A = 0.0515$$

$$B = 0.114$$

$$C = 0.02$$

$$t = 0.50 \cdot \left[\frac{0.0515}{\left(\frac{4}{2}\right)^{0.02} - 1} + 0.1140 \right] = 1.9$$

The operate time in this example will be 1.9 seconds. The same result can be read from Figure 6.67.

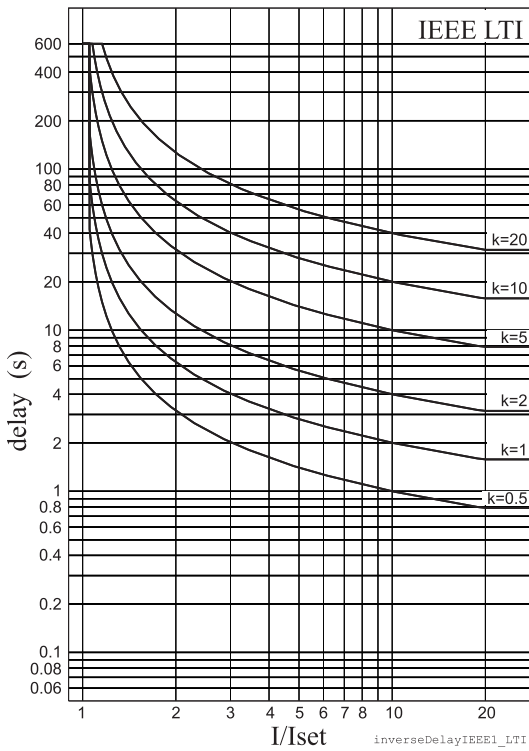

Figure 6.64: ANSI/IEEE long time inverse delay

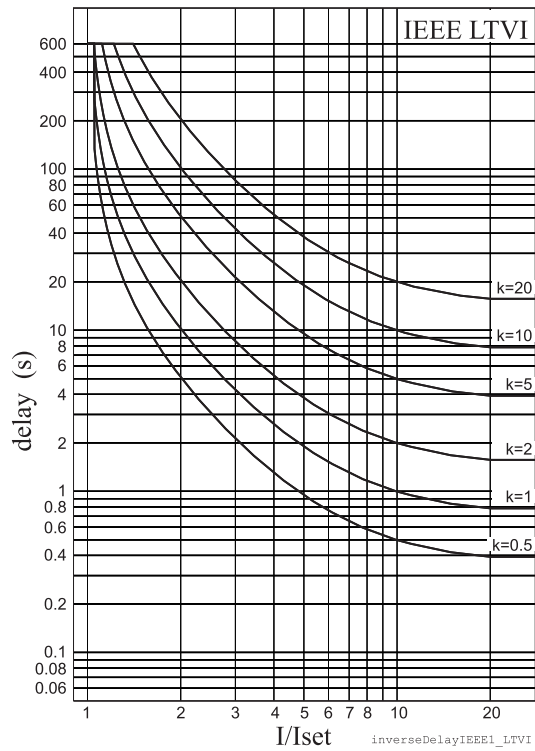

Figure 6.65: ANSI/IEEE long time very inverse delay

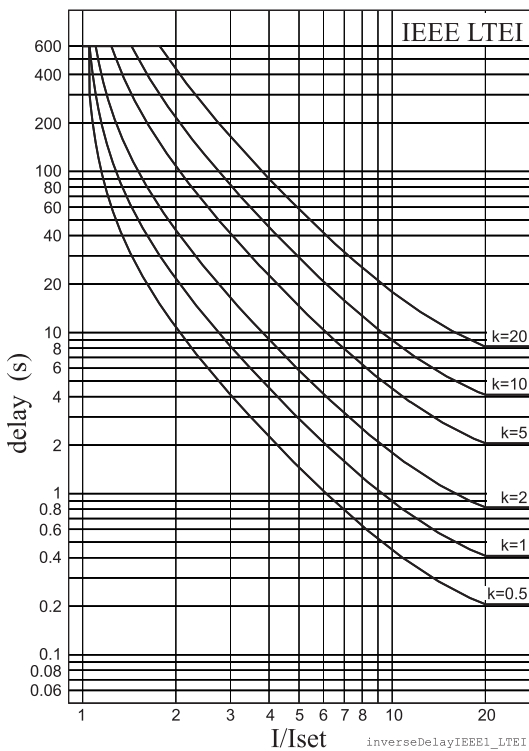

Figure 6.66: ANSI/IEEE long time extremely inverse delay

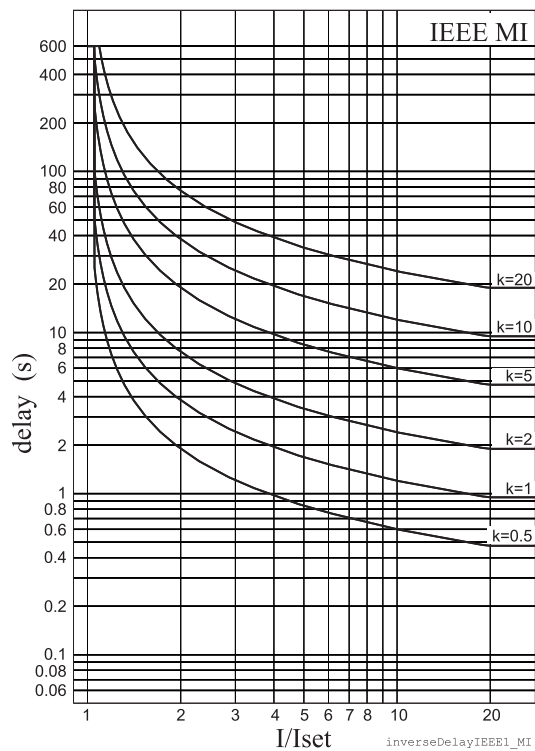

Figure 6.67: ANSI/IEEE moderately inverse delay

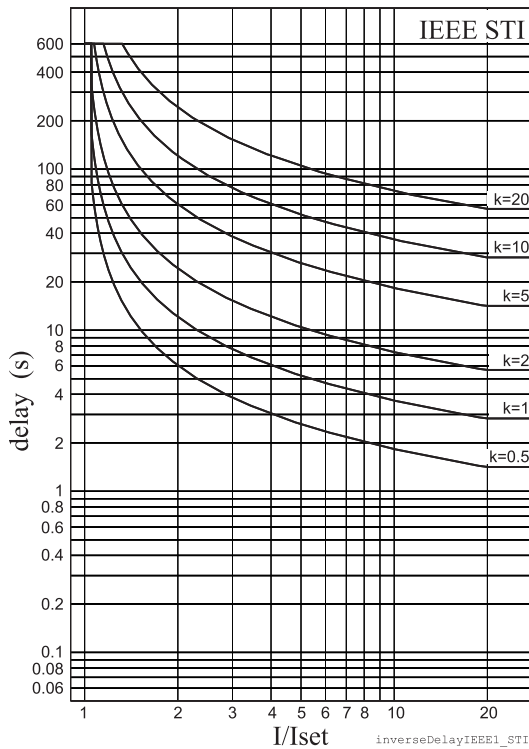

Figure 6.68: ANSI/IEEE short time inverse delay

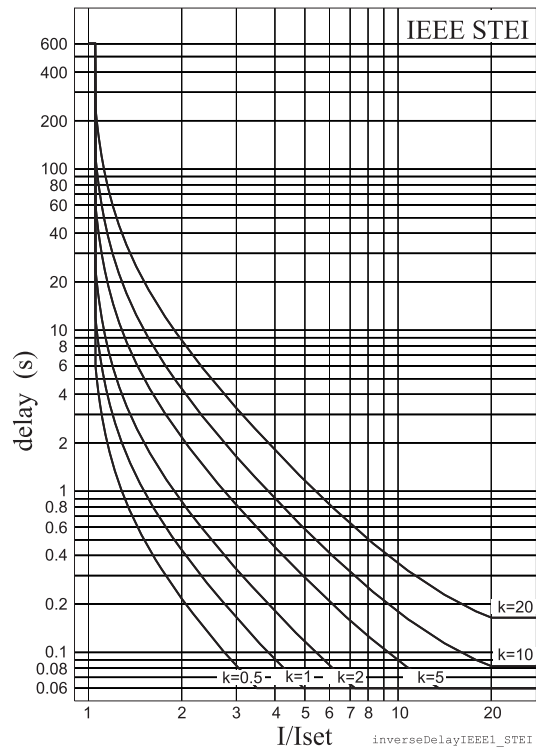

Figure 6.69: ANSI/IEEE short time extremely inverse delay

IEEE2 inverse time operation

Before the year 1996 and ANSI standard C37.112 microprocessor relays were using equations approximating the behaviour of various induction disc type relays. A quite popular approximation is Equation 6.16, which in VAMP relays is called IEEE2. Another name could be IAC, because the old General Electric IAC relays have been modeled using the same equation.

There are four different delay types according Table 6.65. The old electromechanical induction disc relays have inverse delay for both trip and release operations. However, in VAMP relays only the trip time is inverse the release time being constant.

The operation delay depends on the measured value and other parameters according Equation 6.16. Actually this equation can only be used to draw graphs or when the measured value I is constant during the fault. A modified version is implemented in the relay for real time usage.

Equation 6.16:

$$t = k \left[A + \frac{B}{\left(\frac{I}{I_{START}} - C \right)} + \frac{D}{\left(\frac{I}{I_{START}} - C \right)^2} + \frac{E}{\left(\frac{I}{I_{START}} - C \right)^3} \right]$$

t = Operation delay in seconds

k = User's multiplier

I = Measured value

I_{PICKUP} = User's pick up setting

A, B, C, D = Constant parameter according Table 6.65.

Table 6.65: Constants for IEEE2 inverse delay equation

Delay type		Parameter				
		A	B	C	D	E
MI	Moderately inverse	0.1735	0.6791	0.8	-0.08	0.1271
NI	Normally inverse	0.0274	2.2614	0.3	-0.1899	9.1272
VI	Very inverse	0.0615	0.7989	0.34	-0.284	4.0505
EI	Extremely inverse	0.0399	0.2294	0.5	3.0094	0.7222

Example for Delay type "Moderately inverse (MI)":

k = 0.50

I = 4 pu

I_{PICKUP} = 2 pu

A = 0.1735

B = 0.6791

C = 0.8

D = -0.08

E = 0.127

$$t = 0.5 \cdot \left[0.1735 + \frac{0.6791}{\left(\frac{4}{2} - 0.8 \right)} + \frac{-0.08}{\left(\frac{4}{2} - 0.8 \right)^2} + \frac{0.127}{\left(\frac{4}{2} - 0.8 \right)^3} \right] = 0.38$$

The operate time in this example will be 0.38 seconds. The same result can be read from Figure 6.70.

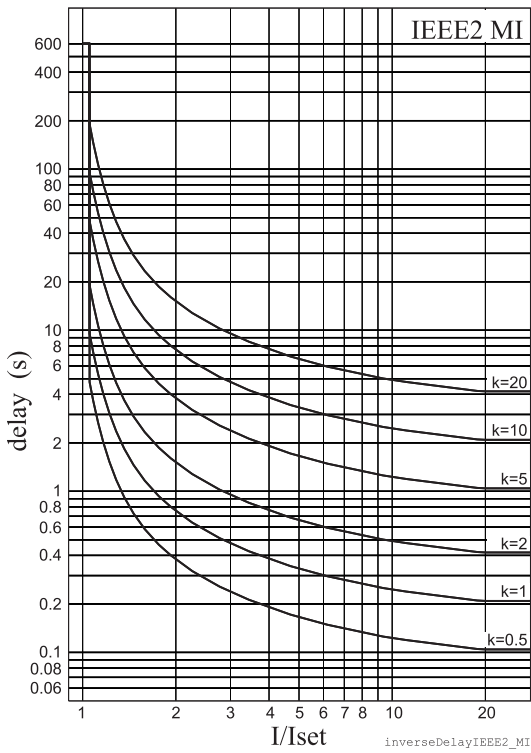

Figure 6.70: IEEE2 moderately inverse delay

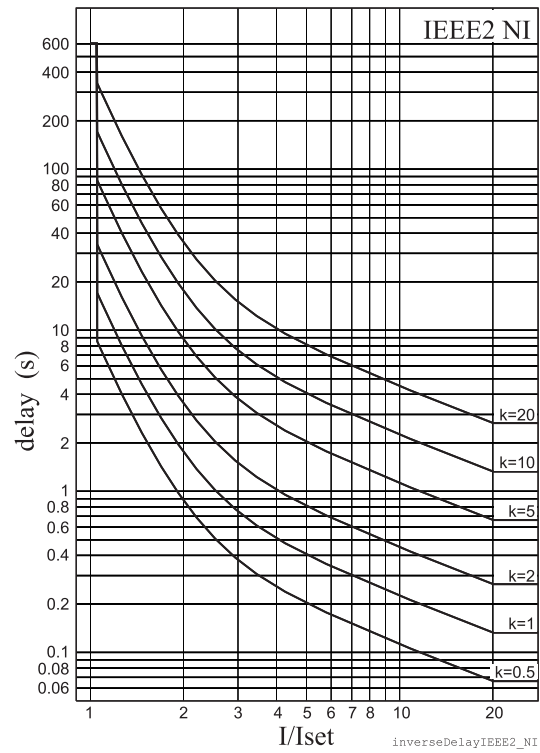

Figure 6.71: IEEE2 normal inverse delay

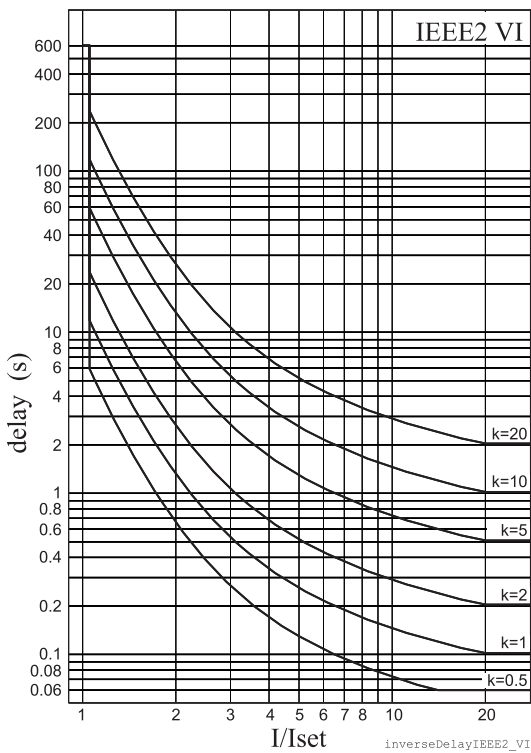

Figure 6.72: IEEE2 very inverse delay

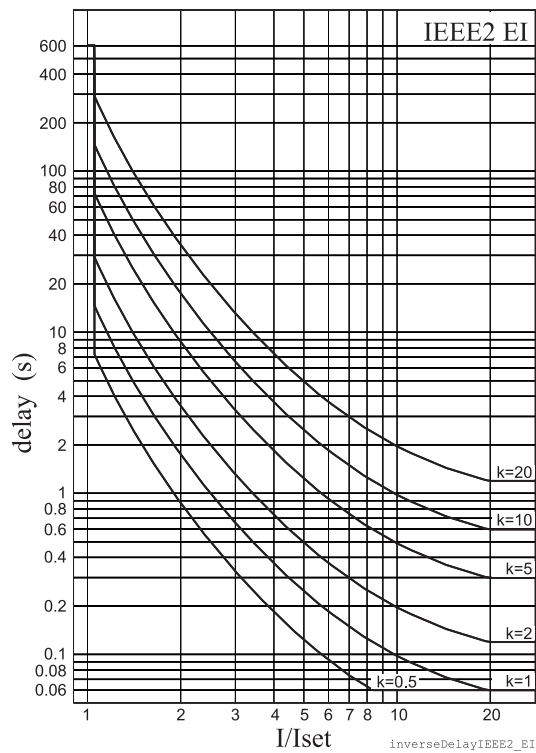

Figure 6.73: IEEE2 extremely inverse delay

RI and RXIDG type inverse time operation

These two inverse delay types have their origin in old ASEA (nowadays ABB) earth fault relays.

The operation delay of types RI and RXIDG depends on the measured value and other parameters according Equation 6.17 and Equation 6.18. Actually these equations can only be used to draw graphs or when the measured value I is constant during the fault. Modified versions are implemented in the relay for real time usage.

Equation 6.17: RI

$$t_{RI} = \frac{k}{0.339 - \frac{0.236}{\left(\frac{I}{I_{START}}\right)}}$$

Equation 6.18: RXIDG

$$t_{RXIDG} = 5.8 - 1.35 \ln \frac{I}{k I_{START}}$$

t = Operation delay in seconds

k = User's multiplier

I = Measured value

I_{PICKUP} = User's pick up setting

Example for Delay type RI

$k = 0.50$

$I = 4$ pu

$I_{PICKUP} = 2$ pu

$$t_{RI} = \frac{0.5}{0.339 - \frac{0.236}{\left(\frac{4}{2}\right)}} = 2.3$$

The operate time in this example will be 2.3 seconds. The same result can be read from Figure 6.74.

Example for Delay type RXIDG

$k = 0.50$

$I = 4$ pu

$I_{PICKUP} = 2$ pu

$$t_{RXIDG} = 5.8 - 1.35 \ln \frac{4}{0.5 \cdot 2} = 3.9$$

The operate time in this example will be 3.9 seconds. The same result can be read from Figure 6.75.

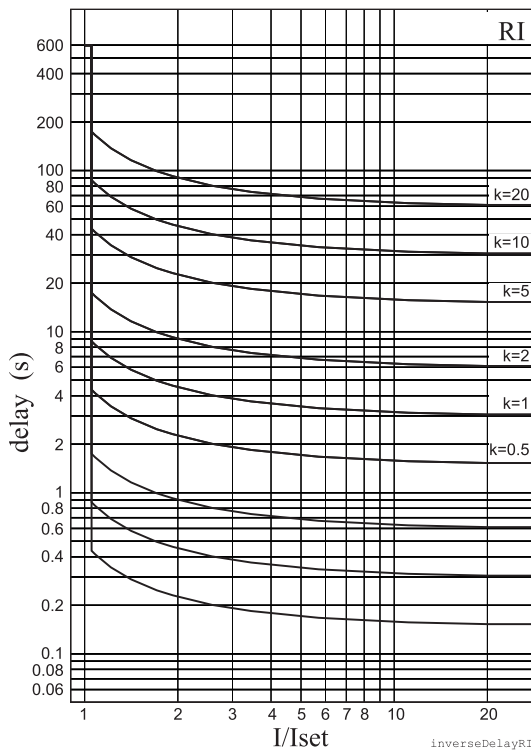

Figure 6.74: Inverse delay of type RI.

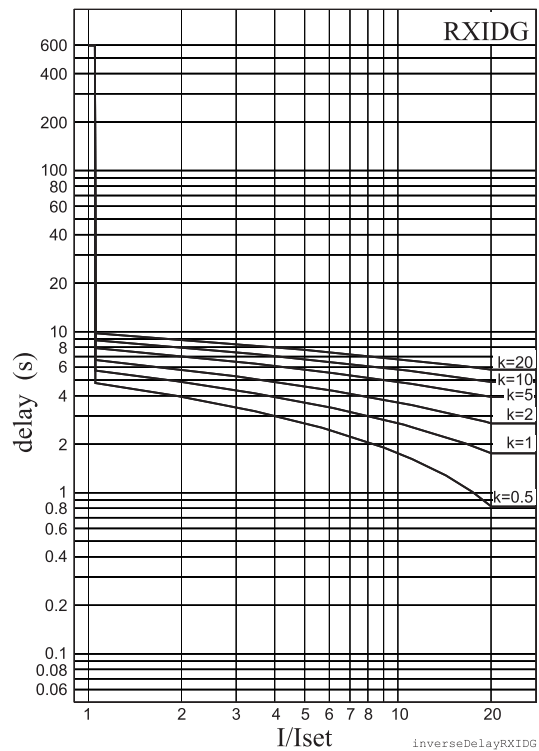

Figure 6.75: Inverse delay of type RXIDG.

6.31.2 Free parameterization using IEC, IEEE and IEEE2 equations

This mode is activated by setting delay type to 'Parameters', and then editing the delay function constants, i.e. the parameters A – E. The idea is to use the standard equations with one's own constants instead of the standardized constants as in the previous chapter.

Example for GE-IAC51 delay type inverse:

$$k = 0.50$$

$$I = 4 \text{ pu}$$

$$I_{\text{PICKUP}} = 2 \text{ pu}$$

$$A = 0.2078$$

$$B = 0.8630$$

$$C = 0.8000$$

$$D = -0.4180$$

$$E = 0.1947$$

$$t = 0.5 \cdot \left[0.2078 + \frac{0.8630}{\left(\frac{4}{2} - 0.8\right)} + \frac{-0.4180}{\left(\frac{4}{2} - 0.8\right)^2} + \frac{0.1947}{\left(\frac{4}{2} - 0.8\right)^3} \right] = 0.37$$

The operate time in this example will be 0.37 seconds.

The resulting time/current characteristic of this example matches quite well with the characteristic of the old electromechanical IAC51 induction disc relay.

Inverse time setting error signal

The inverse time setting error signal will become active, if interpolation with the given parameters is not possible. See Chapter 6.31 Inverse time operation for more details.

Limitations

The minimum definite time delay start latest, when the measured value is twenty times the setting. However, there are limitations at high setting values due to the measurement range. See Chapter 6.31 Inverse time operation for more details.

6.31.3

Programmable inverse time curves

Only with VAMPSET, requires rebooting.

The [current, time] curve points are programmed using VAMPSET PC program. There are some rules for defining the curve points:

- configuration must begin from the topmost line
- line order must be as follows: the smallest current (longest operate time) on the top and the largest current (shortest operate time) on the bottom
- all unused lines (on the bottom) should be filled with [1.00 0.00s]

Here is an example configuration of curve points:

Point	Current I/I _{PICKUP}	Operation delay
1	1.00	10.00 s
2	2.00	6.50 s
3	5.00	4.00 s
4	10.00	3.00 s
5	20.00	2.00 s
6	40.00	1.00 s
7	1.00	0.00 s
8	1.00	0.00 s
9	1.00	0.00 s

Point	Current I/I_{PICKUP}	Operation delay
10	1.00	0.00 s
11	1.00	0.00 s
12	1.00	0.00 s
13	1.00	0.00 s
14	1.00	0.00 s
15	1.00	0.00 s
16	1.00	0.00 s

Inverse time setting error signal

The inverse time setting error signal will be activated, if interpolation with the given points fails. See Chapter 6.31 Inverse time operation for more details.

Limitations

The minimum definite time delay start latest, when the measured value is twenty times the setting. However, there are limitations at high setting values due to the measurement range. See Chapter 6.31 Inverse time operation for more details.

7 Supporting functions

7.1 Event log

Event log is a buffer of event codes and time stamps including date and time. For example each start-on, start-off, trip-on or trip-off of any protection stage has a unique event number code. Such a code and the corresponding time stamp is called an event.

As an example of information included with a typical event a programmable stage trip event is shown in the following table.

EVENT	Description	Local panel	Communication protocols
Code: 01E02	Channel 1, event 2	Yes	Yes
Prg1 trip on	Event text	Yes	No
2.7 x In	Fault value	Yes	No
2007-01-31	Date	Yes	Yes
08:35:13.413	Time	Yes	Yes

Events are the major data for a SCADA system. SCADA systems are reading events using any of the available communication protocols. Event log can also be scanned using the front panel or using VAMPSET. With VAMPSET the events can be stored to a file especially in case the relay is not connected to any SCADA system.

Only the latest event can be read when using communication protocols or VAMPSET. Every reading increments the internal read pointer to the event buffer. (In case of communication interruptions, the latest event can be reread any number of times using another parameter.) On the local panel scanning the event buffer back and forth is possible.

Event enabling/masking

In case of an uninteresting event, it can be masked, which prevents the particular event(s) to be written in the event buffer. As a default there is room for 200 latest events in the buffer. Event buffer size can be modified from 50 to 2000.

Modification can be done in “Local panel conf” –menu.

Indication screen (popup screen) can also be enabled in this same menu when VAMPSET setting tool is used. The oldest one will be overwritten, when a new event does occur. The shown resolution of a time stamp is one millisecond, but the actual resolution depends of the particular function creating the event. For example most protection stages create events with 5ms, 10 ms or 20 ms resolution. The absolute accuracy of all time stamps depends on the time

synchronizing of the relay. See Chapter 7.3 System clock and synchronization for system clock synchronizing.

Event buffer overflow

The normal procedure is to poll events from the device all the time. If this is not done then the event buffer could reach its limits. In such case the oldest event is deleted and the newest displayed with OVF code in HMI.

Table 7.1: Setting parameters for events

Parameter	Value	Description	Note
Count		Number of events	
ClrEn	- Clear	Clear event buffer	Set
Order	Old-New New-Old	Order of the event buffer for local display	Set
FVSca		Scaling of event fault value	Set
	PU	Per unit scaling	
	Pri	Primary scaling	
Display	On	Indication display is enabled	Set
Alarms	Off	No indication display	
FORMAT OF EVENTS ON THE LOCAL DISPLAY			
Code: CHENN		CH = event channel, NN=event code	
Event description		Event channel and code in plain text	
yyyy-mm-dd		Date (for available date formats, see Chapter 7.3 System clock and synchronization)	
hh:mm:ss.nnn		Time	

7.2 Disturbance recorder

The disturbance recorder can be used to record all the measured signals, that is, currents, voltage and the status information of digital inputs (DI) and digital outputs (DO).

The digital inputs also include the arc protection signals.

Triggering the recorder

The recorder can be triggered by any start or trip signal from any protection stage or by a digital input. The triggering signal is selected in the output matrix (vertical signal DR). The recording can also be triggered manually. All recordings are time stamped.

Reading recordings

The recordings can be uploaded, viewed and analysed with the VAMPSET program. The recording is in COMTRADE format. This also means that other programs can be used to view and analyse the recordings made by the relay.

For more details, please see a separate VAMPSET manual.

Number of channels

At the maximum, there can be 12 recordings, and the maximum selection of channels in one recording 12 (limited in wave form) and digital inputs reserve one channel (includes all the inputs). Also the digital outputs reserve one channel (includes all the outputs). If digital inputs and outputs are recorded, there will be still 10 channels left for analogue waveforms.

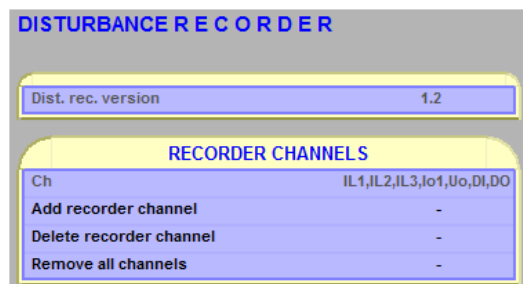

Table 7.2: Disturbance recorder parameters

Parameter	Value	Unit	Description	Note
Mode			Behavior in memory full situation:	Set
	Saturated		No more recordings are accepted	
	Overflow		The oldest recorder will be overwritten	
SR			Sample rate	Set
	32/cycle		Waveform	
	16/cycle		Waveform	
	8/cycle		Waveform	
	1/10ms		One cycle value *)	
	1/20ms		One cycle value **)	
	1/200ms		Average	
	1/1s		Average	
	1/5s		Average	
	1/10s		Average	
	1/15s		Average	
	1/30s		Average	
	1/1min		Average	
Time		s	Recording length	Set
PreTrig		%	Amount of recording data before the trig moment	Set
MaxLen		s	Maximum time setting. This value depends on sample rate, number and type of the selected channels and the configured recording length.	
Status			Status of recording	
	-		Not active	
	Run		Waiting a triggering	
	Trig		Recording	
	FULL		Memory is full in saturated mode	
ManTrig	-, Trig		Manual triggering	Set
ReadyRec	n/m		n = Available recordings / m = maximum number of recordings The value of 'm' depends on sample rate, number and type of the selected channels and the configured recording length.	

Parameter	Value	Unit	Description	Note
AddCh			Add one channel. Maximum simultaneous number of channels is 12.	Set
	IL1, IL2, IL3		Phase current	
	I'L1, I'L2, I'L3		Phase current (IV side)	
	Io1, Io2, Io3		Measured residual current	
	U12, U23, U31		Line-to-line voltage	
	UL1, UL2, UL3		Phase-to-neutral voltage	
	Uo		Zero sequence voltage	
	f		Frequency	
	P, Q, S		Active, reactive, apparent power	
	P.F.		Power factor	
	CosFii		$\cos\phi$	
	IoCalc		Phasor sum $I_o = (I_{L1} + I_{L2} + I_{L3})/3$	
	I1		Positive sequence current	
	I2		Negative sequence current	
	I2/I1		Relative current unbalance	
	I2/In		Current unbalance [$\times I_{MOT}$]	
	IL		Average $(I_{L1} + I_{L2} + I_{L3}) / 3$	
	DI, DO		Digital inputs, Digital outputs	
	TanFii		$\tan\phi$	
	THDIL1, THDIL2, THDIL3		Total harmonic distortion of IL1, IL2 or IL3	
	Prms		Active power rms value	
	Qrms		Reactive power rms value	
	Srms		Apparent power rms value	
	fy		Frequency behind circuit breaker	
	fz		Frequency behind 2nd circuit breaker	
	IL1RMS, IL2MRS, IL3RMS		IL1, IL2, IL3 RMS for average sampling	
	Arc***)		Arc protection signals	
	Starts		Protection stage start signals	
	Trips		Protection stage trip signals	
Delete recorder channel			Delete selected channel	
ClrCh	-, Clear		Remove all channels	Set
(Ch)			List of selected channels	

Set = An editable parameter (password needed).

*) This is the fundamental frequency rms value of one cycle updated every 10 ms.

***) This is the fundamental frequency rms value of one cycle updated every 20 ms.

****) Arc events are polled in every 5 ms.

Signal available depending on the slot 8 options.

For details of setting ranges, see Table 11.54

7.2.1 Running virtual comtrade files

Virtual comtrade files can be run with the device. Device behaviour can be analysed by playing the recorder data over and over again in the relay memory.

NOTE: This is not applicable to the arc protection functions of the device.

Steps of opening the VAMPSET setting tool:

1. Go to “Disturbance record” and select Open... (A).
2. Select the comtrade file from you hard disc or equivalent. VAMPSET is now ready to read the recording.
3. The virtual measurement has to be enabled (B) in order to send record data to the relay (C).
4. Sending the file to the device’s memory takes a few seconds. Initiate playback of the file by pressing the Go! button (D). The “Change to control mode” button takes you back to the virtual measurement.

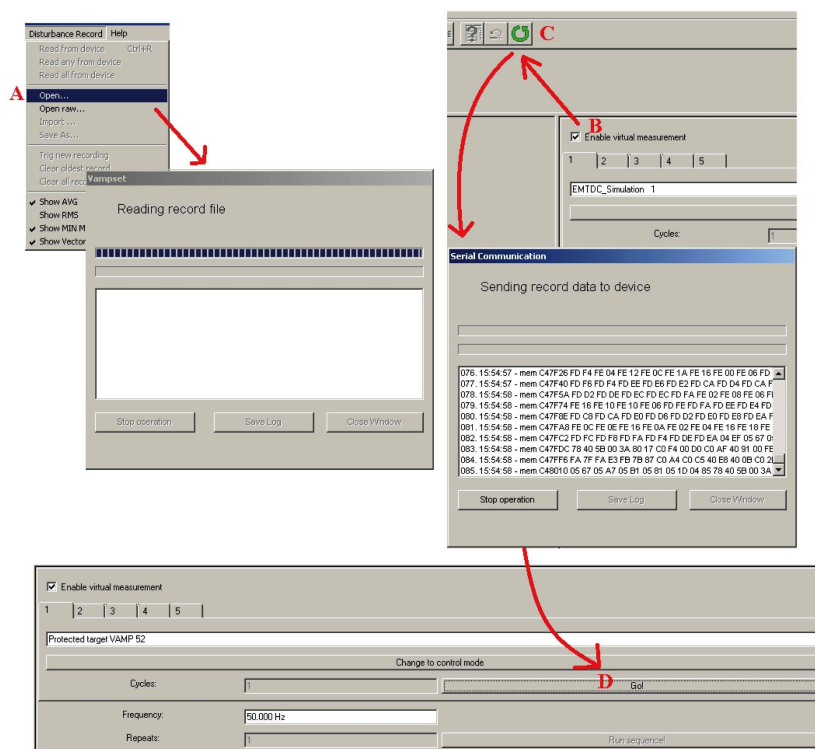

NOTE: The sample rate of the comtrade file has to be 32/cycle (625 micro seconds when 50 Hz is used). The channel names have to correspond to the channel names in VAMP relays: I_{L1} , I_{L2} , I_{L3} , I_{01} , I_{02} , U_{12} , U_{23} , U_{L1} , U_{L2} , U_{L3} and U_0 .

7.2.2 Configuring the disturbance recorder

The disturbance recorder can be used to record all the measured signals, that is, currents, voltages and the status information of digital inputs (DI) and digital outputs (DO).

For this application example, select the channels and sample rate for the disturbance recorder.

1. On the VAMPSET group view, click the **DISTURBANCE RECORDER** menu open.
2. Click the **Add recorder channel** drop-down list and select the channel IL1.
3. Similarly select the channels IL2, IL3, DO and Arc.
4. Click the **Sample rate** drop-down list and select the rate 1/20ms.

To upload, view or analyse the recordings, open VAMPSET and on the **View** menu click **Disturbance Record**.

NOTE: For more information about changing the disturbance recorder settings and evaluating the recordings, see the VAMPSET user manual.

Dist. rec. version	1.2
--------------------	-----

RECORDER CHANNELS	
Ch	IL1,IL2,IL3,DO,Arc
Add recorder channel	-
Remove all channels	-

Recording mode	Overflow
Sample rate	1/20ms
Recording length	8.00 s
Pre trig time	50 %
Event enabling	<input checked="" type="checkbox"/>
Maximum time setting	150.56 s

RECORDER LOG				
	Status	Trig source	Date	hh:mm:ss.ms
[1]	Run	-	-	-
[2]	-	-	-	-
[3]	-	-	-	-
[4]	-	-	-	-
[5]	-	-	-	-
[6]	-	-	-	-
[7]	-	-	-	-
[8]	-	-	-	-
[9]	-	-	-	-
[10]	-	-	-	-
[11]	-	-	-	-
[12]	-	-	-	-

Manual triggering	-
Clear oldest buffer	-
Clear all buffers	-
Status	Run
Recording completion	50 %
Readable records	0/11

Figure 7.1: Configuring the disturbance recorder for the application example

7.3 System clock and synchronization

The internal clock of the relay is used to time stamp events and disturbance recordings.

The system clock should be externally synchronised to get comparable event time stamps for all the relays in the system.

The synchronizing is based on the difference of the internal time and the synchronising message or pulse. This deviation is filtered and the internal time is corrected softly towards a zero deviation.

Time zone offsets

Time zone offset (or bias) can be provided to adjust the local time for the device. The Offset can be set as a Positive (+) or Negative (-) value within a range of -15.00 to +15.00 hours and a resolution of 0.01/h. Basically quarter hour resolution is enough.

Daylight saving time (DST)

The device provides automatic daylight saving adjustments when configured. A daylight savings time (summer time) adjustment can be configured separately and in addition to a time zone offset.

SYSTEM CLOCK	
Date	2014-05-12
Day of week	Monday
Time of day	15:24:47
Date style	y-m-d
Time zone	2 h
Enable DST	<input checked="" type="checkbox"/>
Event enabling	<input checked="" type="checkbox"/>
Status of DST	
Status of DST	ACTIVE
Next DST changes	
Next DSTbegin date	2015-03-29
DSTbegin hour	03:00
Next DSTend date	2014-10-26
DSTend hour (DST)	04:00 DST

Daylight time standards vary widely throughout the world. Traditional daylight/summer time is configured as one (1) hour positive bias. The new US/Canada DST standard, adopted in the spring of 2007 is: one (1) hour positive bias, starting at 2:00am on the second Sunday in March, and ending at 2:00am on the first Sunday in November. In the European Union, daylight change times are defined relative to the UTC time of day instead of local time of day (as in U.S.) European customers, please carefully find out local country rules for DST.

The daylight saving rules for Finland are the device defaults (24-hour clock):

- Daylight saving time start: Last Sunday of March at 03.00
- Daylight saving time end: Last Sunday of October at 04.00

DSTbegin rule	
DSTbegin month	Mar
Ordinal of day of week	Last
Day of week	Sunday
DSTbegin hour	3

DSTend rule	
DSTend month	Oct
Ordinal of day of week	Last
Day of week	Sunday
DSTend hour (DST)	4 DST

To ensure proper hands-free year-around operation, automatic daylight time adjustments must be configured using the “Enable DST” and not with the time zone offset option.

Adapting auto adjust

During tens of hours of synchronizing the device will learn its average deviation and starts to make small corrections by itself. The target is that when the next synchronizing message is received, the deviation is already near zero. Parameters "AAIntv" and "AvDrft" will show the adapted correction time interval of this ±1 ms auto-adjust function.

Time drift correction without external sync

If any external synchronizing source is not available and the system clock has a known steady drift, it is possible to roughly correct the clock deviation by editing the parameters "AAIntv" and "AvDrft". The following equation can be used if the previous "AAIntv" value has been zero.

$$AAIntv = \frac{604.8}{DriftInOneWeek}$$

If the auto-adjust interval "AAIntv" has not been zero, but further trimming is still needed, the following equation can be used to calculate a new auto-adjust interval.

$$AAIntv_{NEW} = \frac{1}{\frac{1}{AAIntv_{PREVIOUS}} + \frac{DriftInOneWeek}{604.8}}$$

The term $DriftInOneWeek/604.8$ may be replaced with the relative drift multiplied by 1000, if some other period than one week has been

used. For example if the drift has been 37 seconds in 14 days, the relative drift is $37 \cdot 1000 / (14 \cdot 24 \cdot 3600) = 0.0306$ ms/s.

Example 1

If there has been no external sync and the relay's clock is leading sixty-one seconds a week and the parameter *AAIntv* has been zero, the parameters are set as

$$AvDrft = Lead$$

$$AAIntv = \frac{604.8}{61} = 9.9s$$

With these parameter values the system clock corrects itself with -1 ms every 9.9 seconds which equals -61.091 s/week.

Example 2

If there is no external sync and the relay's clock has been lagging five seconds in nine days and the *AAIntv* has been 9.9 s, leading, then the parameters are set as

$$AAIntv_{NEW} = \frac{1}{\frac{1}{9.9} - \frac{1}{9 \cdot 24 \cdot 3600}} = 10.6$$

$$AvDrft = Lead$$

When the internal time is roughly correct – deviation is less than four seconds – any synchronizing or auto-adjust will never turn the clock backwards. Instead, in case the clock is leading, it is softly slowed down to maintain causality.

Table 7.3: System clock parameters

Parameter	Value	Unit	Description	Note
Date			Current date	Set
Time			Current time	Set
Style			Date format	Set
	y-d-m		Year-Month-Day	
	d.m.y		Day.Month.Year	
	m/d/y		Month/Day/Year	
SyncDI	Possible values depends on the types of I/O cards		The digital input used for clock synchronisation.	****)
	-		DI not used for synchronizing	
TZone	-15.00 – +15.00 *)		UTC time zone for SNTP synchronization. Note: This is a decimal number. For example for state of Nepal the time zone 5:45 is given as 5.75	Set
DST	No; Yes		Daylight saving time for SNTP	Set

Parameter	Value	Unit	Description	Note
SySrc			Clock synchronisation source	
	Internal		No sync recognized since 200s	
	DI		Digital input	
	SNTP		Protocol sync	
	SpaBus		Protocol sync	
	ModBus		Protocol sync	
	ModBus TCP		Protocol sync	
	ProfibusDP		Protocol sync	
	IEC101		Protocol sync	
	IEC103		Protocol sync	
	DNP3		Protocol sync	
	IRIG-B003		IRIG timecode B003 ****)	
MsgCnt	0 – 65535, 0 – etc.		The number of received synchronisation messages or pulses	
Dev	±32767	ms	Latest time deviation between the system clock and the received synchronization	
SyOS	±10000.000	s	Synchronisation correction for any constant deviation in the synchronizing source	Set
AAIntv	±1000	s	Adapted auto adjust interval for 1 ms correction	Set**)
AvDrft	Lead; Lag		Adapted average clock drift sign	Set**)
FilDev	±125	ms	Filtered synchronisation deviation	

Set = An editable parameter (password needed).

*) A range of -11 h – +12 h would cover the whole Earth but because the International Date Line does not follow the 180° meridian, a more wide range is needed.

***) If external synchronization is used this parameter will be set automatically.

****) Set the DI delay to its minimum and the polarity such that the leading edge is the synchronizing edge.

*****) Relay needs to be equipped with suitable hardware option module to receive IRIG-B clock synchronization signal. (Chapter 13 Order information).

Synchronisation with DI

Clock can be synchronized by reading minute pulses from digital inputs, virtual inputs or virtual outputs. Sync source is selected with **SyncDI** setting. When rising edge is detected from the selected input, system clock is adjusted to the nearest minute. Length of digital input pulse should be at least 50 ms. Delay of the selected digital input should be set to zero.

Synchronisation correction

If the sync source has a known offset delay, it can be compensated with **SyOS** setting. This is useful for compensating hardware delays or transfer delays of communication protocols. A positive value will compensate a lagging external sync and communication delays. A negative value will compensate any leading offset of the external sync source.

Sync source

When the device receives new sync message, the sync source display is updated. If no new sync messages are received within next 1.5 minutes, the device will change to internal sync mode.

Sync source: IRIG-B

IRIG standard time formats B003 and B004 are supported with a dedicated communication option with either a two-pole or two pins in a D9 rear connector (See Chapter 13 Order information).

IRIG-B input clock signal voltage level is TLL. The input clock signal originated in the GPS receiver must be taken to multiple relays through an IRIG-B distribution module. This module acts as a centralized unit for a point-to-multiple point connection. Note: Daisy chain connection of IRIG-B signal inputs in multiple relays must be avoided.

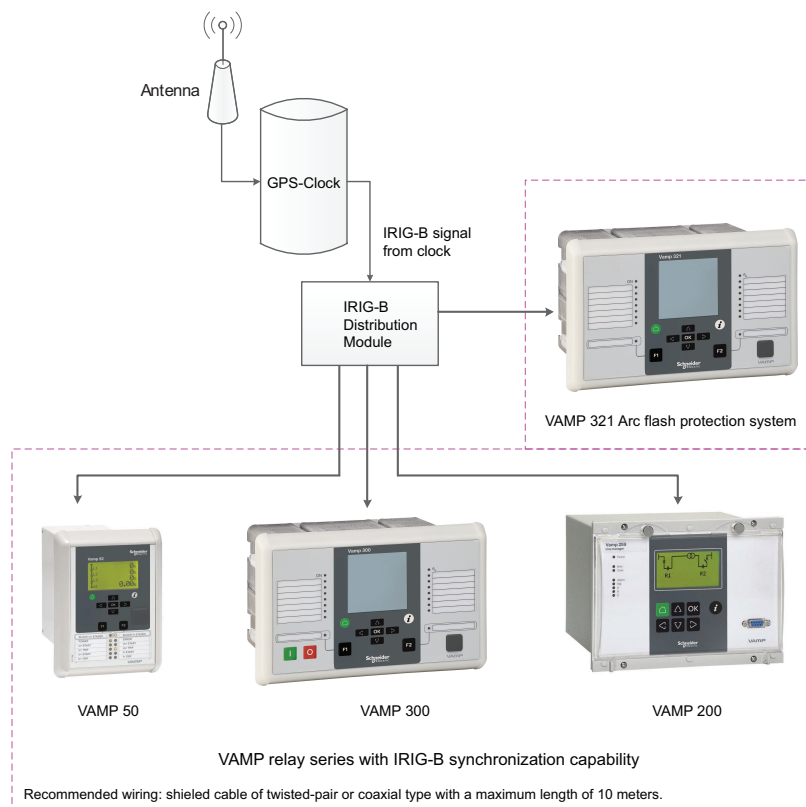

The recommended cable must be shielded and either of coaxial or twisted pair type. Its length should not exceed a maximum of 10 meters.

Deviation

The time deviation means how much system clock time differs from sync source time. Time deviation is calculated after receiving new sync message. The filtered deviation means how much the system clock was really adjusted. Filtering takes care of small deviation in sync messages.

Auto-lag/lead

The device synchronizes to the sync source, meaning it starts automatically leading or lagging to stay in perfect sync with the master. The learning process takes few days.

7.4 Self-supervision

The functions of the microcontroller and the associated circuitry, as well as the program execution are supervised by means of a separate watchdog circuit. Besides supervising the relay, the watchdog circuit attempts to restart the micro controller in an inoperable situation. If the micro controller does not restart, the watchdog issues a self-supervision signal indicating a permanent internal condition.

When the watchdog circuit detects a permanent fault, it always blocks any control of other output relays (except for the self-supervision output relay). In addition, the internal supply voltages are supervised. Should the auxiliary supply of the device disappear, an indication is automatically given because the device status inoperative (SF) output relay functions on a working current principle. This means that the SF relay is energized when the auxiliary supply is on and the VAMP 300G device is fully operational.

In order to get self-supervision alarms to SF output contact they must be linked in the DIAGNOSIS setting view's section SELFDIAG SIGNAL CONFIGURATION. Required alarms are first linked to a Selfdiag1, Selfdiag2 or Selfdiag3 group (Figure 7.2).

SELFDIAG SIGNAL CONFIGURATION	
SecPulse	Selfdiag1
Relays	Selfdiag1
E2PROM	Selfdiag1
Stack usage	Selfdiag1
Memory check	Selfdiag1
Background task	Selfdiag1
Parameter range check	Selfdiag1
CPU load	Selfdiag1
Internal voltage +	Selfdiag1
Low auxiliary voltage	Selfdiag1
Internal temperature	Selfdiag1
ADC check 1	Selfdiag1
ADC check 2	Selfdiag1
COM buffer	Selfdiag1
Slot card	Selfdiag1
Order code	Selfdiag1
FPGA version	Selfdiag2
FPGA configuration	Selfdiag2
Arc sensor	Selfdiag2
BI	Selfdiag2

Figure 7.2: Selfdiag alarm signal configuration

Having the Seldiag alarm grouping made then the appropriate alarms can be assigned to SF relay. By default, selfdiag alarm 2 is linked to SF relay (Figure 7.3). Function of this default setup is same as in the older systems where this configuration was not possible.

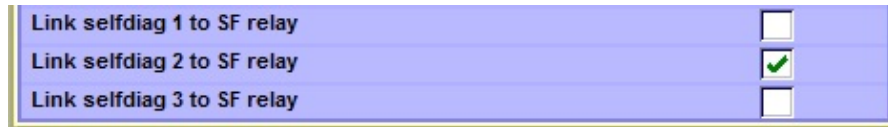

Figure 7.3: Linking Selfdiag alarm 1-3 to SF relay

It is possible to choose, what selfdiag alarms 1-3 does when activated. This option can be done through output matrix (Figure 7.4). This allows customer to categorize and prioritize actions for each selfdiag alarms individually. For example in this configuration selfdiag alarm 3 activates VO6.

	T1	A1	DR	VO1	VO2	VO3	VO4	VO5	VO6	T9	T10	T11	T12	T13	T14	T15	T16	T17	T18	T19	T20	
Selfdiag 1 alarm	<input checked="" type="checkbox"/>	<input checked="" type="checkbox"/>	<input checked="" type="checkbox"/>	<input checked="" type="checkbox"/>	<input checked="" type="checkbox"/>	<input checked="" type="checkbox"/>	<input checked="" type="checkbox"/>	<input checked="" type="checkbox"/>	<input checked="" type="checkbox"/>	<input checked="" type="checkbox"/>	<input checked="" type="checkbox"/>	<input checked="" type="checkbox"/>	<input checked="" type="checkbox"/>	<input checked="" type="checkbox"/>	<input checked="" type="checkbox"/>	<input checked="" type="checkbox"/>	<input checked="" type="checkbox"/>	<input checked="" type="checkbox"/>	<input checked="" type="checkbox"/>	<input checked="" type="checkbox"/>	<input checked="" type="checkbox"/>	<input checked="" type="checkbox"/>
Selfdiag 2 alarm	<input type="checkbox"/>	<input type="checkbox"/>	<input type="checkbox"/>	<input type="checkbox"/>	<input type="checkbox"/>	<input type="checkbox"/>	<input type="checkbox"/>	<input type="checkbox"/>	<input type="checkbox"/>	<input type="checkbox"/>	<input type="checkbox"/>	<input type="checkbox"/>	<input type="checkbox"/>	<input type="checkbox"/>	<input type="checkbox"/>	<input type="checkbox"/>	<input type="checkbox"/>	<input type="checkbox"/>	<input type="checkbox"/>	<input type="checkbox"/>	<input type="checkbox"/>	<input type="checkbox"/>
Selfdiag 3 alarm	<input type="checkbox"/>	<input type="checkbox"/>	<input type="checkbox"/>	<input type="checkbox"/>	<input type="checkbox"/>	<input type="checkbox"/>	<input type="checkbox"/>	<input type="checkbox"/>	<input checked="" type="checkbox"/>	<input type="checkbox"/>	<input type="checkbox"/>	<input type="checkbox"/>	<input type="checkbox"/>	<input type="checkbox"/>	<input type="checkbox"/>	<input type="checkbox"/>	<input type="checkbox"/>	<input type="checkbox"/>	<input type="checkbox"/>	<input type="checkbox"/>	<input type="checkbox"/>	<input type="checkbox"/>

Figure 7.4: Selecting selfdiag 1-3 actions. Number of outputs varies depending of device and order code.

7.4.1 Diagnostics

The device runs self-diagnostic tests for hardware and software in boot sequence and also performs runtime checking.

Permanent inoperative state

If permanent inoperative state has been detected, the device releases SF relay contact and status LED is set on. Local panel will also display a detected fault message. Permanet inoperative state is entered when the device is not able to handle main functions.

Temporal inoperative state

When self-diagnostic function detects a temporal inoperative state, Selfdiag matrix signal is set and an event (E56) is generated. In case the inoperative state was only temporary, an off event is generated (E57). Self diagnostic state can be reset via local HMI.

Diagnostic registers

There are four 16-bit diagnostic registers which are readable through remote protocols. The following table shows the meaning of each diagnostic register and their bits.

Register	Bit	Code	Description
SelfDiag1	0 (LSB)	(Reserved)	(Reserved)
	1	(Reserved)	(Reserved)
	2	T1	Detected output relay fault
	3	T2	
	4	T3	
	5	T4	
	6	T5	
	7	T6	
	8	T7	
	9	T8	
	10	A1	
	11	A2	
	12	A3	
	13	A4	
	14	A5	
15	T9		
SelfDiag2	0 (LSB)	T10	Detected output relay fault
	1	T11	
	2	T12	
	3	T13	
	4	T14	
	5	T15	
	6	T16	
	7	T17	
	8	T18	
	9	T19	
	10	T20	
	11	T21	
	12	T22	
	13	T23	
	14	T24	
SelfDiag4	0 (LSB)	+12V	Detected internal voltage fault
	1	ComBuff	BUS: detected buffer error
	2	Order Code	Detected order code error
	3	Slot card	Detected option card error
	4	FPGA conf.	Detected FPGA configuration error
	5	I/O unit	Detected ARC I/O unit error
	6	Arc sensor	Detected faulty arc sensor
	7	QD-card error	Detected QD-card error
	8	BI	Detected ARC BI error
	9	LowAux	Low auxiliary supply voltage

The code is displayed in self diagnostic events and on the diagnostic menu on local panel and VAMPSET.

7.5 Voltage sags and swells

The power quality of electrical networks has become increasingly important. The sophisticated loads (e.g. computers etc.) require uninterruptible supply of “clean” electricity. VAMP protection platform provides many power quality functions that can be used to evaluate, monitor and alarm on the basis of the quality. One of the most important power quality functions are voltage sag and swell monitoring.

VAMP provides separate monitoring logs for sags and swells. The voltage log is triggered, if any voltage input either goes under the sag limit (U<) or exceeds the swell limit (U>). There are four registers for both sags and swells in the fault log. Each register will have start time, phase information, duration, minimum, average, maximum voltage values of each sag and swell event. Furthermore, there are total number of sags and swells counters as well as total timers for sags and swells.

The voltage power quality functions are located under the submenu “U”.

Table 7.4: Setting parameters of sags and swells monitoring

Parameter	Value	Unit	Default	Description
U>	20 – 150	%	110	Setting value of swell limit
U<	10 – 120	%	90	Setting value of sag limit
Delay	0.04 – 1.00	s	0.06	Delay for sag and swell detection
SagOn	On; Off	-	On	Sag on event
SagOff	On; Off	-	On	Sag off event
SwelOn	On; Off	-	On	Swell on event
SwelOf	On; Off	-	On	Swell off event

Table 7.5: Recorded values of sags and swells monitoring

	Parameter	Value	Unit	Description
Recorded values	Count		-	Cumulative sag counter
	Total		-	Cumulative sag time counter
	Count		-	Cumulative swell counter
	Total		-	Cumulative swell time counter
Sag / swell logs 1 – 4	Date		-	Date of the sag/swell
	Time		-	Time stamp of the sag/swell
	Type		-	Voltage inputs that had the sag/swell
	Time		s	Duration of the sag/swell
	Min1		% Un	Minimum voltage value during the sag/swell in the input 1
	Min2		% Un	Minimum voltage value during the sag/swell in the input 2
	Min3		% Un	Minimum voltage value during the sag/swell in the input 3
	Ave1		% Un	Average voltage value during the sag/swell in the input 1
	Ave2		% Un	Average voltage value during the sag/swell in the input 2
	Ave3		% Un	Average voltage value during the sag/swell in the input 3
	Max1		% Un	Maximum voltage value during the sag/swell in the input 1
	Max2		% Un	Maximum voltage value during the sag/swell in the input 2
	Max3		% Un	Maximum voltage value during the sag/swell in the input 3

For details of setting ranges, see Table 11.58

7.6 Voltage interruptions

The device includes a simple function to detect voltage interruptions. The function calculates the number of voltage interruptions and the total time of the voltage-off time within a given calendar period. The period is based on the real time clock of the device. The available periods are:

- 8 hours, 00:00 – 08:00, 08:00 – 16:00, 16:00 – 24:00
- one day, 00:00 – 24:00
- one week, Monday 00:00 – Sunday 24:00
- one month, the first day 00:00 – the last day 24:00
- one year, 1st January 00:00 – 31st December 24:00

After each period, the number of interruptions and the total interruption time are stored as previous values. The interruption

counter and the total time are cleared for a new period. The old previous values are overwritten.

The voltage interruption is based on the value of the positive sequence voltage U_1 and a user given limit value. Whenever the measured U_1 goes below the limit, the interruption counter is increased, and the total time counter starts increasing.

Shortest recognized interruption time is 40 ms. If the voltage-off time is shorter it may be recognized depending on the relative depth of the voltage dip.

If the voltage has been significantly over the limit $U_1 <$ and then there is a small and short under-swing, it will not be recognized (Figure 7.5).

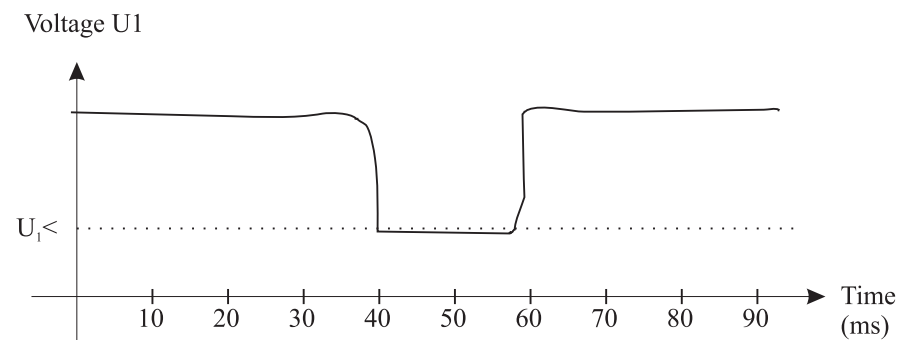

Figure 7.5: A short voltage interruption which is probably not recognized

On the other hand, if the limit $U_1 <$ is high and the voltage has been near this limit, and then there is a short but very deep dip, it will be recognized (Figure 7.6).

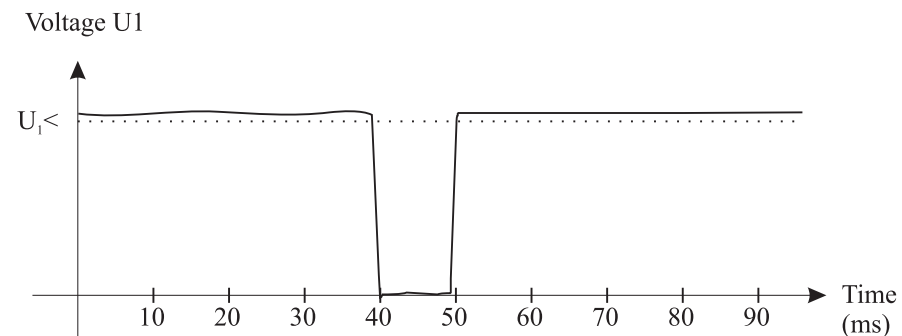

Figure 7.6: A short voltage interrupt that will be recognized

Table 7.6: Setting parameters of the voltage sag measurement function:

Parameter	Value	Unit	Default	Description
U1<	10.0 – 120.0	%	64	Setting value
Period	8h Day Week Month	-	Month	Length of the observation period
Date		-	-	Date
Time		-	-	Time

Table 7.7: Measured and recorded values of voltage sag measurement function:

	Parameter	Value	Unit	Description
Measured value	Voltage	LOW; OK	-	Current voltage status
	U1		%	Measured positive sequence voltage
Recorded values	Count		-	Number of voltage sags during the current observation period
	Prev		-	Number of voltage sags during the previous observation period
	Total		s	Total (summed) time of voltage sags during the current observation period
	Prev		s	Total (summed) time of voltage sags during the previous observation period

For details of setting ranges, see Table 0.1

7.7 Current transformer supervision

The relay supervise the external wiring between the relay terminals and current transformers (CT) and the CT themselves. Furthermore, this is a safety function as well, since an open secondary of a CT, causes dangerous voltages.

The CT supervisor function measures phase currents. If one of the three phase currents drops below $I_{MIN}<$ setting, while another phase current is exceeding the $I_{MAX}>$ setting, the function will issue an alarm after the operation delay has elapsed.

Table 7.8: Setting parameters of CT supervisor CTSV

Parameter	Value	Unit	Default	Description
$I_{max}>$	0.0 – 10.0	xI_N	2.0	Upper setting for CT supervisor current scaled to primary value, calculated by relay
$I_{min}<$	0.0 – 10.0	xI_N	0.2	Lower setting for CT supervisor current scaled to primary value, calculated by relay
$t>$	0.02 – 600.0	s	0.10	Operation delay
CT on	On; Off	-	On	CT supervisor on event
CT off	On; Off	-	On	CT supervisor off event

Table 7.9: Measured and recorded values of CT supervisor CTSV

	Parameter	Value	Unit	Description
Measured value	ILmax		A	Maximum of phase currents
	ILmin		A	Minimum of phase currents
Display	$I_{max}>$, $I_{min}<$		A	Setting values as primary values
Recorded values	Date		-	Date of CT supervision alarm
	Time		-	Time of CT supervision alarm
	I _{max}		A	Maximum phase current
	I _{min}		A	Minimum phase current

For details of setting ranges, see Table 11.56

7.8 Voltage transformer supervision

The device supervises the VTs and VT wiring between the device terminals and the VTs. If there is a fuse in the voltage transformer circuitry, the blown fuse prevents or distorts the voltage measurement. Therefore, an alarm should be issued. Furthermore, in some applications, protection functions using voltage signals, should be blocked to avoid false tripping.

The VT supervisor function measures the three phase voltages and currents. The negative sequence voltage U_2 and the negative sequence current I_2 are calculated. If U_2 exceed the $U_2>$ setting and at the same time, I_2 is less than the $I_2<$ setting, the function will issue an alarm after the operation delay has elapsed.

Table 7.10: Setting parameters of VT supervisor VTSV ()

Parameter	Value	Unit	Default	Description
U2>	0.0 – 200.0	% Un	34.6	Upper setting for VT supervisor
I2<	0.0 – 200.0	% In	100.0	Lower setting for VT supervisor
t>	0.02 – 600.0	s	0.10	Operation delay
VT on	On; Off	-	On	VT supervisor on event
VT off	On; Off	-	On	VT supervisor off event

Table 7.11: Measured and recorded values of VT supervisor VTSV ()

	Parameter	Value	Unit	Description
Measured value	U2		% Un	Measured negative sequence voltage
	I2		% In	Measured negative sequence current
Recorded Values	Date		-	Date of VT supervision alarm
	Time		-	Time of VT supervision alarm
	U2		% Un	Recorded negative sequence voltage
	I2		% In	Recorded negative sequence current

For details of setting ranges, see Table 11.57

7.9 Circuit breaker condition monitoring

The relay has a condition monitoring function that supervises the wearing of the circuit-breaker. The condition monitoring can give alarm for the need of CB maintenance well before the CB condition is critical.

The CB wear function measures the breaking current of each CB pole separately and then estimates the wearing of the CB accordingly the permissible cycle diagram. The breaking current is registered when the trip relay supervised by the circuit breaker failure protection (CBFP) is activated. (See Chapter 6.27 Circuit breaker failure protection CBFP (50BF) for CBFP and the setting parameter "CBrelay".)

Breaker curve and its approximation

The permissible cycle diagram is usually available in the documentation of the CB manufacturer (Figure 7.7). The diagram specifies the permissible number of cycles for every level of the breaking current. This diagram is parameterised to the condition monitoring function with maximum eight [current, cycles] points. See Table 7.12. If less than eight points needed, the unused points are set to $[I_{BIG}, 1]$, where I_{BIG} is more than the maximum breaking capacity.

If the CB wearing characteristics or part of it is a straight line on a log/log graph, the two end points are enough to define that part of the characteristics. This is because the relay is using logarithmic

interpolation for any current values falling in between the given current points 2 – 8.

The points 4 – 8 are not needed for the CB in Figure 7.7. Thus they are set to 100 kA and one operation in the table to be discarded by the algorithm.

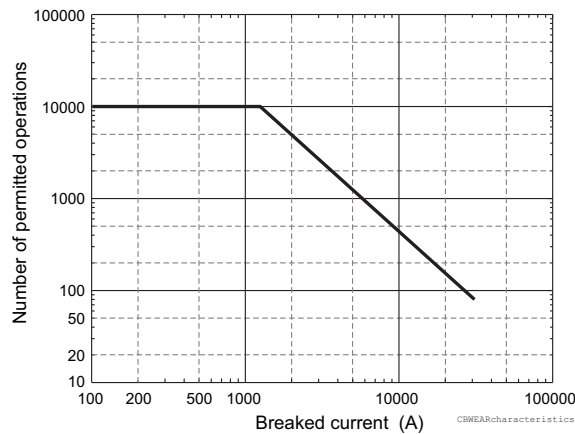

Figure 7.7: An example of a circuit breaker wearing characteristic graph.

Table 7.12: An example of circuit breaker wearing characteristics in a table format. The values are taken from the figure above. The table is edited with VAMPSET under menu "BREAKER CURVE".

Point	Interrupted current (kA)	Number of permitted operations
1	0 (mechanical age)	10000
2	1.25 (rated current)	10000
3	31.0 (maximum breaking current)	80
4	100	1
5	100	1
6	100	1
7	100	1
8	100	1

Setting alarm points

There are two alarm points available having two setting parameters each.

- **Current**
The first alarm can be set for example to nominal current of the CB or any application typical current. The second alarm can be set for example according a typical fault current.
- **Operations left alarm limit**
An alarm is activated when there are less operation left at the given current level than this limit.

Any actual interrupted current will be logarithmically weighted for the two given alarm current levels and the number of operations left at the alarm points is decreased accordingly. When the "operations left" i.e. the number of remaining operations, goes under the given alarm limit, an alarm signal is issued to the output matrix. Also an event is generated depending on the event enabling.

Clearing "operations left" counters

After the breaker curve table is filled and the alarm currents are defined, the wearing function can be initialised by clearing the decreasing operation counters with parameter "Clear" (Clear oper. left cntrs). After clearing the relay will show the maximum allowed operations for the defined alarm current levels.

Operation counters to monitor the wearing

The operations left can be read from the counters "Al1Ln" (Alarm 1) and "Al2Ln" (Alarm2). There are three values for both alarms, one for each phase. The smallest of three is supervised by the two alarm functions.

Logarithmic interpolation

The permitted number of operations for currents in between the defined points are logarithmically interpolated using equation

Equation 7.1:

$$C = \frac{a}{I^n}$$

C = permitted operations

I = interrupted current

a = constant according Equation 7.2

n = constant according Equation 7.3

Equation 7.2:

$$n = \frac{\ln \frac{C_k}{C_{k+1}}}{\ln \frac{I_{k+1}}{I_k}}$$

ln = natural logarithm function

C_k, C_{k+1} = permitted operations. k = row 2 – 7 in Table 7.12.

I_k, I_{k+1} = corresponding current. k = row 2 – 7 in Table 7.12.

Equation 7.3:

$$a = C_k I_k^2$$

Example of the logarithmic interpolation

Alarm 2 current is set to 6 kA. What is the maximum number of operations according Table 7.12.

The current 6 kA lies between points 2 and 3 in the table. That gives value for the index k. Using

$$k = 2$$

$$C_k = 10000$$

$$C_{k+1} = 80$$

$$I_{k+1} = 31 \text{ kA}$$

$$I_k = 1.25 \text{ kA}$$

and the Equation 7.2 and Equation 7.3, the relay calculates

$$n = \frac{\ln \frac{10000}{80}}{\ln \frac{31000}{1250}} = 1.5038$$

$$a = 10000 \cdot 1250^{1.5038} = 454 \cdot 10^6$$

Using Equation 7.1 the relay gets the number of permitted operations for current 6 kA.

$$C = \frac{454 \cdot 10^6}{6000^{1.5038}} = 945$$

Thus the maximum number of current breaking at 6 kA is 945. This can be verified with the original breaker curve in Figure 7.7. Indeed, the figure shows that at 6 kA the operation count is between 900 and 1000. A useful alarm level for operation-left, could be in this case for example 50 being about five per cent of the maximum.

Example of operation counter decrementing when the CB is breaking a current

Alarm2 is set to 6 kA. CBFP is supervising trip relay T1 and trip signal of an overcurrent stage detecting a two phase fault is connected to this trip relay T1. The interrupted phase currents are 12.5 kA, 12.5 kA and 1.5 kA. How many are Alarm2 counters decremented?

Using Equation 7.1 and values n and a from the previous example, the relay gets the number of permitted operation at 10 kA.

$$C_{10kA} = \frac{454 \cdot 10^6}{12500^{1.5038}} = 313$$

At alarm level 2, 6 kA, the corresponding number of operations is calculated according

Equation 7.4:

$$\Delta = \frac{C_{AlarmMax}}{C}$$

$$\Delta_{L1} = \Delta_{L2} = \frac{945}{313} = 3$$

Thus Alarm2 counters for phases L1 and L2 are decremented by 3. In phase L1 the currents is less than the alarm limit current 6 kA. For such currents the decrement is one.

$$\Delta_{L3} = 1$$

Table 7.13: Local panel parameters of CBWEAR function

Parameter	Value	Unit	Description	Set
CBWEAR STATUS				
AI1L1			Operations left for - Alarm 1, phase L1	
AI1L2			- Alarm 1, phase L2	
AI1L3			- Alarm 1, phase L3	
AI2L1			- Alarm 2, phase L1	
AI2L2			- Alarm 2, phase L2	
AI2L3			- Alarm 2, phase L3	
Latest trip				
Date time			Time stamp of the latest trip operation	
IL1		A	Broken current of phase L1	
IL2		A	Broken current of phase L2	
IL3		A	Broken current of phase L3	
CBWEAR SET				
Alarm1				
Current	0.00 – 100.00	kA	Alarm1 current level	Set
Cycles	100000 – 1		Alarm1 limit for operations left	Set
Alarm2				
Current	0.00 – 100.00	kA	Alarm2 current level	Set
Cycles	100000 – 1		Alarm2 limit for operations left	Set
CBWEAR SET2				
AI1On	On ; Off		'Alarm1 on' event enabling	Set
AI1Off	On ; Off		'Alarm1 off' event enabling	Set
AI2On	On ; Off		'Alarm2 on' event enabling	Set
AI2Off	On ; Off		'Alarm2 off' event enabling	Set
Clear	-; Clear		Clearing of cycle counters	Set

Set = An editable parameter (password needed).

The breaker curve table is edited with VAMPSET.

7.10 Energy pulse outputs

The device can be configured to send a pulse whenever certain amount of energy has been imported or exported. The principle is presented in Figure 7.8. Each time the energy level reaches the pulse size, an output relay is activated and the relay will be active as long as defined by a pulse duration setting.

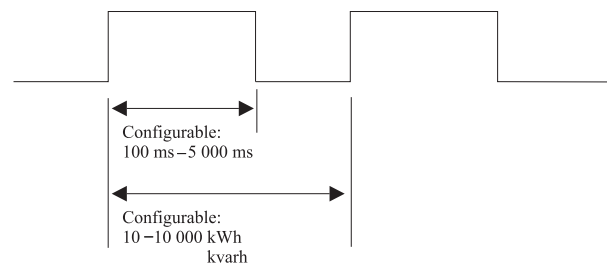

Figure 7.8: Principle of energy pulses

The relay has four energy pulse outputs. The output channels are:

- Active exported energy
- Reactive exported energy
- Active imported energy
- Reactive imported energy

Each channel can be connected to any combination of the output relays using output matrix. The parameters for the energy pulses can be found in the E menu under the submenus E-PULSE SIZES and E-PULSE DURATION.

Table 7.14: Energy pulse output parameters

	Parameter	Value	Unit	Description
E-PULSE SIZES	E+	10 – 10 000	kWh	Pulse size of active exported energy
	Eq+	10 – 10 000	kvarh	Pulse size of reactive exported energy
	E-	10 – 10 000	kWh	Pulse size of active imported energy
	Eq-	10 – 10 000	kvarh	Pulse size of reactive imported energy
E-PULSE DURATION	E+	100 – 5000	ms	Pulse length of active exported energy
	Eq+	100 – 5000	ms	Pulse length of reactive exported energy
	E-	100 – 5000	ms	Pulse length of active imported energy
	Eq-	100 – 5000	ms	Pulse length of reactive imported energy

Scaling examples

1. Average active exported power is 250 MW.
Peak active exported power is 400 MW.
Pulse size is 250 kWh.
The average pulse frequency will be $250/0.250 = 1000$ pulses/h.
The peak pulse frequency will be $400/0.250 = 1600$ pulses/h.
Set pulse length to $3600/1600 - 0.2 = 2.0$ s or less.
The lifetime of the mechanical output relay will be $50 \times 10^6 / 1000$ h = 6 a.
This is not a practical scaling example unless an output relay lifetime of about six years is accepted.
2. Average active exported power is 100 MW.
Peak active exported power is 800 MW.
Pulse size is 400 kWh.
The average pulse frequency will be $100/0.400 = 250$ pulses/h.
The peak pulse frequency will be $800/0.400 = 2000$ pulses/h.
Set pulse length to $3600/2000 - 0.2 = 1.6$ s or less.
The lifetime of the mechanical output relay will be $50 \times 10^6 / 250$ h = 23 a.
3. Average active exported power is 20 MW.
Peak active exported power is 70 MW.
Pulse size is 60 kWh.
The average pulse frequency will be $25/0.060 = 416.7$ pulses/h.
The peak pulse frequency will be $70/0.060 = 1166.7$ pulses/h.
Set pulse length to $3600/1167 - 0.2 = 2.8$ s or less.
The lifetime of the mechanical output relay will be $50 \times 10^6 / 417$ h = 14 a.
4. Average active exported power is 1900 kW.
Peak active exported power is 50 MW.
Pulse size is 10 kWh.
The average pulse frequency will be $1900/10 = 190$ pulses/h.
The peak pulse frequency will be $50000/10 = 5000$ pulses/h.
Set pulse length to $3600/5000 - 0.2 = 0.5$ s or less.
The lifetime of the mechanical output relay will be $50 \times 10^6 / 190$ h = 30 a.

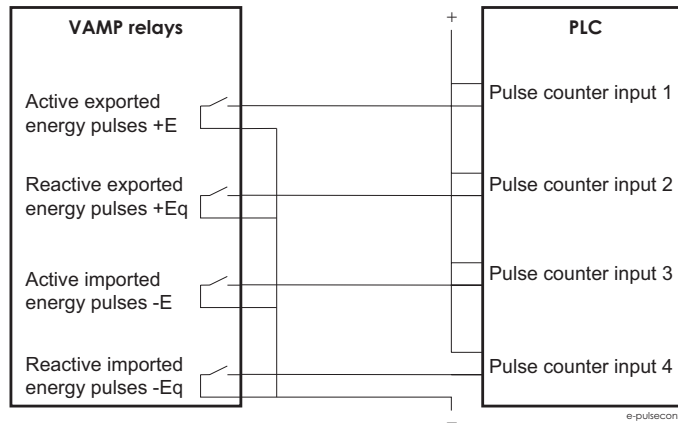

Figure 7.9: Application example of wiring the energy pulse outputs to a PLC having common plus and using an external wetting voltage

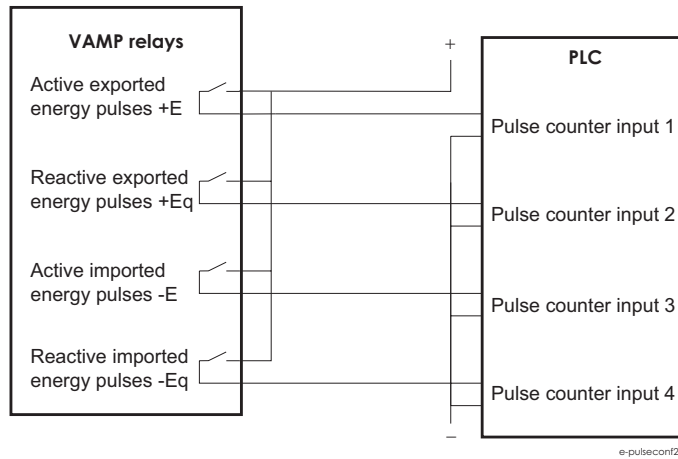

Figure 7.10: Application example of wiring the energy pulse outputs to a PLC having common minus and using an external wetting voltage

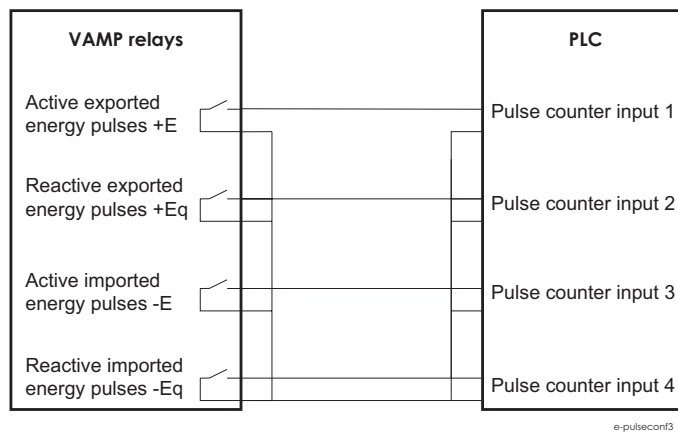

Figure 7.11: Application example of wiring the energy pulse outputs to a PLC having common minus and an internal wetting voltage.

7.11 Running hour counter

This function calculates the total active time of the selected digital input, virtual I/O or output matrix output signal. The resolution is ten seconds.

Table 7.15: Running hour counter parameters

Parameter	Value	Unit	Description	Note
Runh	0 – 876000	h	Total active time, hours Note: The label text "Runh" can be edited with VAMPSET.	(Set)
Runs	0 – 3599	s	Total active time, seconds	(Set)
Starts	0 – 65535		Activation counter	(Set)
Status	Stop Run		Current status of the selected digital signal	
Started at			Date and time of the last activation	
Stopped at			Date and time of the last inactivation	

Set = An editable parameter (password needed).

(Set) = An informative value which can be edited as well.

7.12 Timers

The VAMP protection platform includes four settable timers that can be used together with the user's programmable logic or to control setting groups and other applications that require actions based on calendar time. Each timer has its own settings. The selected on-time and off-time is set and then the activation of the timer can be set to be as daily or according the day of week (See the setting parameters for details). The timer outputs are available for logic functions and for the block and output matrix.

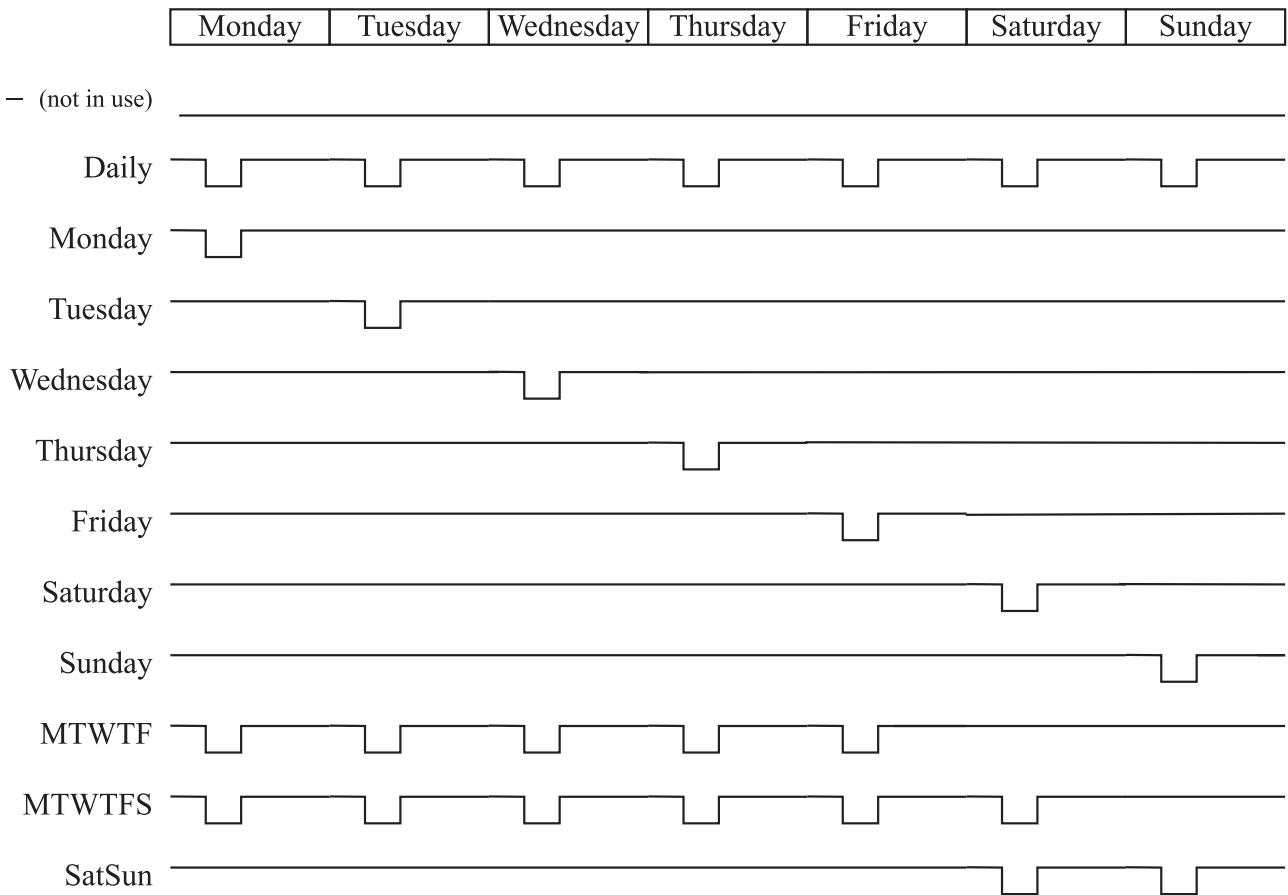

Figure 7.12: Timer output sequence in different modes.

The user can force any timer, which is in use, on or off. The forcing is done by writing a new status value. No forcing flag is needed as in forcing i.e. the output relays.

The forced time is valid until the next forcing or until the next reversing timed act from the timer itself.

The status of each timer is stored in non-volatile memory when the auxiliary power is switched off. At start up, the status of each timer is recovered.

Table 7.16: Setting parameters of timers

Parameter	Value	Description
TimerN		Timer status
	-	Not in use
	0	Output is inactive
	1	Output is active
On	hh:mm:ss	Activation time of the timer
Off	hh:mm:ss	De-activation time of the timer
Mode		For each four timers there are 12 different modes available:
	-	The timer is off and not running. The output is off i.e. 0 all the time.
	Daily	The timer switches on and off once every day.
	Monday	The timer switches on and off every Monday.
	Tuesday	The timer switches on and off every Tuesday.
	Wednesday	The timer switches on and off every Wednesday.
	Thursday	The timer switches on and off every Thursday.
	Friday	The timer switches on and off every Friday.
	Saturday	The timer switches on and off every Saturday.
	Sunday	The timer switches on and off every Sunday.
	MTWTF	The timer switches on and off every day except Saturdays and Sundays
	MTWTFS	The timer switches on and off every day except Sundays.
	SatSun	The timer switches on and off every Saturday and Sunday.

7.13 Combined overcurrent status

This function is collecting faults, fault types and registered fault currents of all enabled overcurrent stages.

Combined over current status can be used as an indication of faults. Combined o/c indicates the amplitude of the last occurred fault. Also a separate indication of the fault type is informed during the start and the trip. Active phases during the start and the trip are also activated in the output matrix. After the fault is switched off the active signals will release after the set delay “clearing delay“ has passed. The combined o/c status refers to the following over current stages: $I_{>}$, $I_{>>}$, $I_{>>>}$, $I_{\phi>}$, $I_{\phi>>}$, $I_{\phi>>>}$ and $I_{\phi>>>>}$.

Table 7.17: Line fault parameters

Parameter	Value	Unit	Description	Note
IFitLas		xImode	Current of the latest overcurrent fault	(Set)
LINE ALARM				
AlrL1			Start (=alarm) status for each phase.	
AlrL2	0		0 = No start since alarm ClrDly	
AlrL3	1		1 = Start is on	
OCs	0 1		Combined overcurrent start status. AlrL1 = AlrL2 = AlrL3 = 0 AlrL1 = 1 or AlrL2 = 1 or AlrL3 = 1	
LxAlarm	On Off		'On' Event enabling for AlrL1 – 3 Events are enabled Events are disabled	Set
LxAlarmOff	On Off		'Off' Event enabling for AlrL1...3 Events are enabled Events are disabled	Set
OCAAlarm	On Off		'On' Event enabling for combined o/c starts Events are enabled Events are disabled	Set
OCAAlarmOff	On Off		'Off' Event enabling for combined o/c starts Events are enabled Events are disabled	Set
IncFitEvt	On Off		Disabling several start <u>and</u> trip events of the same fault Several events are enabled *) Several events of an increasing fault is disabled **)	Set
ClrDly	0 – 65535	s	Duration for active alarm status AlrL1, AlrL2, AlrL3 and OCs	Set

Parameter	Value	Unit	Description	Note
LINE FAULT				
FitL1			Fault (=trip) status for each phase.	
FitL2	0		0 = No fault since fault ClrDly	
FitL3	1		1 = Fault is on	
OCt	0		Combined overcurrent trip status. FitL1 = FitL2 = FitL3 = 0	
	1		FitL1 = 1 or FitL2 = 1 or FitL3 = 1	
LxTrip	On		'On' Event enabling for FitL1 – 3 Events are enabled	Set
	Off		Events are disabled	
LxTripOff	On		'Off' Event enabling for FitL1...3 Events are enabled	Set
	Off		Events are disabled	
OCTrip	On		'On' Event enabling for combined o/c trips Events are enabled	Set
	Off		Events are disabled	
OCTripOff	On		'Off' Event enabling for combined o/c starts Events are enabled	Set
	Off		Events are disabled	
IncFltEvnt	On		Disabling several events of the same fault Several events are enabled *)	Set
	Off		Several events of an increasing fault is disabled **)	
ClrDly	0 – 65535		Duration for active alarm status FitL1, Fit2, FitL3 and OCt	Set

Set = An editable parameter (password needed).

*) Used with IEC 60870-105-103 communication protocol. The alarm screen will show the latest if it's the biggest registered fault current, too. Not used with Spabus, because Spabus masters usually don't like to have unpaired On/Off events.

***) Used with SPA-bus protocol, because most SPA-bus masters do need an off-event for each corresponding on-event.

Combined o/c status		
Last fault current	3.00	xIn
Line 1 alarm	1	
Line 2 alarm	0	
Line 3 alarm	0	
Overcurrent alarm	1	
Clearing delay for alarm value	10	s
Line 1 fault	1	
Line 2 fault	1	
Line 3 fault	0	
Overcurrent trip	1	
Clearing delay for fault value	10	s

Figure 7.13: Combined o/c status.

The fault that can be seen in the Figure 7.13 was 3 times to nominal and it started as an one phase fault L1-E. At the moment when one of the protection stages tripped the fault was already increased in to a two phase short circuit L1-L2. All signals those are stated as “1” are also activated in the output matrix. After the fault disappears the activated signals will release.

Combined over current status can be found from VAMPSET menu “protection stage status 2”.

8 Communication and protocols

8.1 Communication ports

The device has one fixed communication port: USB port in front for connection to VAMPSET setting and configuration tool.

Optionally the device may have up to 2 serial ports COM 3 and COM 4 for serial protocols (for example IEC 103) and one ETHERNET port for Ethernet-based communication protocols (for example IEC 61850).

The number of available serial ports depends on the type of the communication option cards.

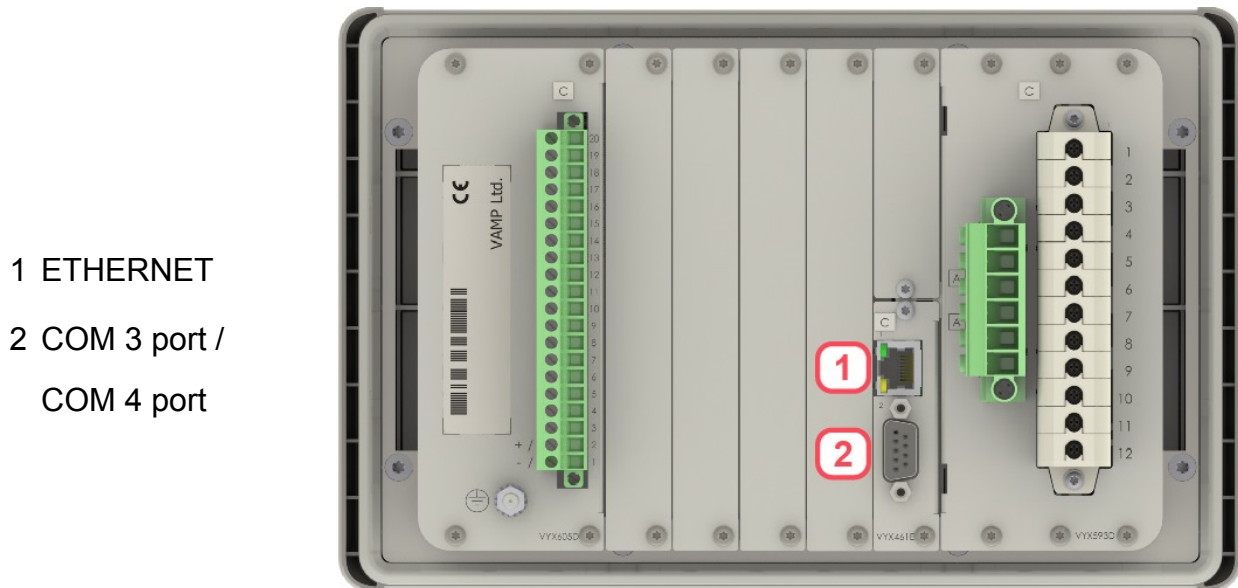

Figure 8.1: VAMP 300 IED fixed communication ports in different slots.

NOTE: It is possible to have up to 2 serial communication protocols simultaneously in the same D9 connector but restriction is that same protocol can be used only once.

Protocol configuration menu contains selection for the protocol, port settings and message/error/timeout counters.

PROTOCOL CONFIGURATION

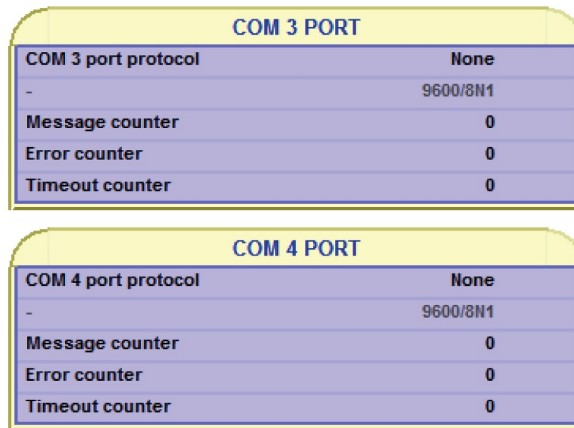

Figure 8.2: Protocols can be enabled in “protocol configuration” menu. Only serial communication protocols are valid with RS-232 interface.

Table 8.1: Parameters

Parameter	Value	Unit	Description	Note
Protocol			Protocol selection for COM port	Set
	None		-	
	SPA-bus		SPA-bus (slave)	
	ProfibusDP		Interface to Profibus DB module VPA 3CG (slave)	
	ModbusSlv		Modbus RTU slave	
	IEC-103		IEC-60870-5-103 (slave)	
	ExternalIO		Modbus RTU master for external I/O-modules	
	IEC 101		IEC-608670-5-101	
	DNP3		DNP 3.0	
	DeviceNet		Interface to DeviceNet module VSE 009	
GetSet		Communicationi protocols for VAMPSET interface		
Msg#	0 – 2 ³² - 1		Message counter since the device has restarted or since last clearing	Clr
Errors	0 – 2 ¹⁶ - 1		Protocol interruption since the device has restarted or since last clearing	Clr
Tout	0 – 2 ¹⁶ - 1		Timeout interruption since the device has restarted or since last clearing	Clr
	speed/DPS		Display of current communication parameters. speed = bit/s D = number of data bits P = parity: none, even, odd S = number of stop bits	1.

Set = An editable parameter (password needed)

Clr = Clearing to zero is possible

1. The communication parameters are set in the protocol specific menus. For the local port command line interface the parameters are set in configuration menu.

8.1.1 Ethernet port

TCP port 1st INST and TCP port 2nd INST are ports for ethernet communication protocols. Ethernet communication protocols can be selected to these ports when such hardware option is installed. The parameters for these ports are set via local HMI or with VAMPSET in menus TCP port 1st INST and TCP port 2nd INST. Two different protocols can be used simultaneously on one physical interface (both protocols use the same IP address and MAC address but different IP port).

NOTE: It is possible to have 2 ethernet communication protocols simultaneously but restriction is that same protocol can be used only once.

ETHERNET PORT	
IP Address	10.4.128.100
NetMask	255.255.255.0
Gateway	10.4.128.254
NTP server	10.4.128.250
IP port for setting tool	23
TCP keepalive interval	0 s
Enable FTP server	<input checked="" type="checkbox"/>
FTP password	config
FTP max speed	4 kB/s
MAC address	001AD3004DA6
Storm protection	<input type="checkbox"/>
Storm protection limit	1.0 %

TCP PORT 1st INST	
Ethernet port protocol	IEC-61850
IP port for protocol	102
Message counter	106
Error counter	0
Timeout counter	0

TCP PORT 2nd INST	
Ethernet port protocol 2nd inst	None
IP port for protocol 2nd inst	502
Message counter	0
Error counter	0
Timeout counter	0

Figure 8.3: Protocols can be enabled in “protocol configuration” menu. With ethernet option it is possible to use TCP -based communication protocols.

Protocol configuration menu contains address and other related information for the ethernet port. TCP port 1st and 2nd instance include selection for the protocol, IP port settings and message/error/timeout counters. More information about the protocol configuration menu on table below.

Table 8.2: Main configuration parameters (local display), inbuilt Ethernet port

Parameter	Value	Unit	Description	Note
Protocol			Protocol selection for the extension port	Set
	None		Command line interface for VAMPSET	
	ModbusTCPs		Modbus TCP slave	
	IEC-101		IEC-101	
	IEC 61850		IEC-61850 protocol	
	EtherNet/IP		Ethernet/IP protocol	
	DNP3		DNP/TCP	
Port	nnn		Ip port for protocol, default 102	Set
IpAddr	n.n.n.n		Internet protocol address (set with VAMPSET)	Set
NetMsk	n.n.n.n		Net mask (set with VAMPSET)	Set
Gatew	default = 0.0.0.0		Gateway IP address (set with VAMPSET)	Set
NTPSvr	n.n.n.n		Network time protocol server (set with VAMPSET) 0.0.0.0 = no SNTP	Set
KeepAlive	nn		TCP keepalive interval	Set 1)
FTP server	on/off		Enable FTP server	Set
FTP speed	4 Kb/s (default)		Maximum transmission speed for FTP	Set
FTP password	? (user) config (configurator)		FTP password	Set
MAC address	001ADnnnnnnn		MAC address	
VS Port	nn 23 (default)		IP port for VAMPSET	Set
Msg#	nnn		Message counter	
Errors	nnn		Error counter	
Tout	nnn		Timeout counter	
EthSffEn	on/off		Sniffer port enable	Set
SniffPort	Port2		Sniffer port	

Set = An editable parameter (password needed)

1) KeepAlive: The KeepAlive parameter sets in seconds the time between two keepalive packets are sent from the IED. The setting range for this parameter is between zero (0) and 20 seconds; with the exception that zero (0) means actually 120 seconds (2 minutes). A keep alive's packet purpose is for the VAMP IED to send a probe packet to a connected client for checking the status of the TCP-connection when no other packet is being sent e.g. client does not poll data from the IED. If the keepalive packet is not acknowledged, the IED will close the TCP connection. Connection must be resumed on the client side.

Table 8.3: TCP PORT 1st INST

Parameter	Value	Unit	Description	Note
Protocol			Protocol selection for the extension port.	Set
	None		Command line interface for VAMPSET	
	ModbusTCPs		Modbus TCP slave	
	IEC 61850		IEC-61850 protocol	
	EtherNet/IP		Ethernet/IP protocol	
	DNP3		DNP/TCP	
Port	nnn		Ip port for protocol, default 502	Set
Msg#	nnn		Message counter	
Errors	nnn		Error counter	
Tout	nnn		Timeout counter	

Table 8.4: CP PORT 2nd INST

Parameter	Value	Unit	Description	Note
Ethernet port protocol (TCP PORT 2nd INST)			Protocol selection for the extension port.	Set
	None		Command line interface for VAMPSET	
	ModbusTCPs		Modbus TCP slave	
	IEC 61850		IEC-61850 protocol	
	EtherNet/IP		Ethernet/IP protocol	
	DNP3		DNP/TCP	
Port	nnn		Ip port for protocol, default 502	Set
Msg#	nnn		Message counter	
Errors	nnn		Error counter	
Tout	nnn		Timeout counter	

Set = An editable parameter (password needed).

8.2 Communication protocols

The protocols enable the transfer of the following type of data:

- events
- status information
- measurements
- control commands
- clock synchronizing
- Settings (SPA-bus and embedded SPA-bus only)

8.2.1 GetSet

This is an ASCII protocol used by VAMPSET. This protocol is the protocol used on the USB port. This can also be used on the COM ports, if VAMPSET interface via these ports is required.

8.2.2 Modbus TCP and Modbus RTU

These Modbus protocols are often used in power plants and in industrial applications. The difference between these two protocols is the media. Modbus TCP uses Ethernet and Modbus RTU uses asynchronous communication (RS-485, optic fibre, RS-232).

VAMPSET will show the list of all available data items for Modbus.

The Modbus communication is activated via a menu selection with parameter "Protocol". See Chapter 8.1 Communication ports.

For Ethernet interface configuration, see Chapter 8.1.1 Ethernet port.

Table 8.5: Parameters

Parameter	Value	Unit	Description	Note
Addr	1 – 247		Modbus address for the device. Broadcast address 0 can be used for clock synchronizing. Modbus TCP uses also the TCP port settings.	Set
bit/s	1200 2400 4800 9600 19200	bps	Communication speed for Modbus RTU	Set
Parity	None Even Odd		Parity for Modbus RTU	Set

Set = An editable parameter (password needed)

8.2.3 Profibus DP

The Profibus DP protocol is widely used in industry. An external VPA 3CG and VX072 cables are required.

Device profile "continuous mode"

In this mode, the device is sending a configured set of data parameters continuously to the Profibus DP master. The benefit of this mode is the speed and easy access to the data in the Profibus master. The drawback is the maximum buffer size of 128 bytes, which limits the number of data items transferred to the master. Some PLCs have their own limitation for the Profibus buffer size, which may further limit the number of transferred data items.

Device profile "Request mode"

Using the request mode it is possible to read all the available data from the VAMP device and still use only a very short buffer for Profibus data transfer. The drawback is the slower overall speed of the data transfer and the need of increased data processing at the Profibus master as every data item must be separately requested by the master.

NOTE: In request mode, it is not possible to read continuously only one single data item. At least two different data items must be read in turn to get updated data from the device.

There is a separate manual for VPA 3CG (VVPA3CG/EN M/xxxx) for the continuous mode and request mode. The manual is available to download from our website.

Available data

VAMPSET will show the list of all available data items for both modes. A separate document "Profibus parameters.pdf" is also available.

The Profibus DP communication is activated usually for remote port via a menu selection with parameter "Protocol". See Chapter 8.1 Communication ports.

Table 8.6: Parameters

Parameter	Value	Unit	Description	Note
Mode			Profile selection	Set
	Cont		Continuous mode	
	Reqst		Request mode	
bit/s	2400	bps	Communication speed from the main CPU to the Profibus converter. (The actual Profibus bit rate is automatically set by the Profibus master and can be up to 12 Mbit/s.)	
Emode			Event numbering style.	(Set)
	Channel		Use this for new installations.	
	(Limit60)		(The other modes are for compatibility with old systems.)	
	(NoLimit)			
InBuf		bytes	Size of Profibus master's Rx buffer. (data to the master)	1. 3.
OutBuf		bytes	Size of Profibus master's Tx buffer. (data from the master)	2. 3.
Addr	1 – 247		This address has to be unique within the Profibus network system.	Set
Conv			Converter type	4.
	-		No converter recognized	
	VE		Converter type "VE" is recognized	

Set = An editable parameter (password needed)

Clr = Clearing to zero is possible

1. In continuous mode the size depends of the biggest configured data offset of a data item to be send to the master. In request mode the size is 8 bytes.
2. In continuous mode the size depends of the biggest configured data offset of a data to be read from the master. In request mode the size is 8 bytes.
3. When configuring the Profibus master system, the lengths of these buffers are needed. The device calculates the lengths according the Profibus data and profile configuration and the values define the in/out module to be configured for the Profibus master.
4. If the value is "-", Profibus protocol has not been selected or the device has not restarted after protocol change or there is a communication problem between the main CPU and the Profibus ASIC.

8.2.4 SPA-bus

The device has full support for the SPA-bus protocol including reading and writing the setting values. Also reading of multiple consecutive status data bits, measurement values or setting values with one message is supported.

Several simultaneous instances of this protocol, using different physical ports, are possible, but the events can be read by one single instance only.

There is a separate document “Spabus parameters.pdf” of SPA-bus data items available.

Table 8.7: Parameters

Parameter	Value	Unit	Description	Note
Addr	1 – 899		SPA-bus address. Must be unique in the system.	Set
bit/s	1200 2400 4800 9600 (default) 19200	bps	Communication speed	Set
Emode			Event numbering style.	(Set)
	Channel		Use this for new installations.	
	(Limit60)		(The other modes are for compatibility with old systems.)	
	(NoLimit)			

Set = An editable parameter (password needed)

8.2.5 IEC 60870-5-103

The IEC standard 60870-5-103 "*Companion standard for the informative interface of protection equipment*" provides standardized communication interface to a primary system (master system).

The unbalanced transmission mode of the protocol is used, and the device functions as a secondary station (slave) in the communication. Data is transferred to the primary system using "data acquisition by polling"-principle.

The IEC functionality includes application functions:

- station initialization
- general interrogation
- clock synchronization and
- command transmission.

It is not possible to transfer parameter data or disturbance recordings via the IEC 103 protocol interface.

The following ASDU (Application Service Data Unit) types will be used in communication from the device:

- ASDU 1: time tagged message
- ASDU 3: Measurands I
- ASDU 5: Identification message
- ASDU 6: Time synchronization and
- ASDU 8: Termination of general interrogation.

The device will accept:

- ASDU 6: Time synchronization
- ASDU 7: Initiation of general interrogation and
- ASDU 20: General command.

The data in a message frame is identified by:

- type identification
- function type and
- information number.

These are fixed for data items in the compatible range of the protocol, for example, the trip of I> function is identified by: type identification = 1, function type = 160 and information number = 90. "Private range" function types are used for such data items, which are not defined by the standard (e.g. the status of the digital inputs and the control of the objects).

The function type and information number used in private range messages is configurable. This enables flexible interfacing to different master systems.

For more information on IEC 60870-5-103 in VAMP devices refer to the “IEC103 Interoperability List” document.

Table 8.8: Parameters

Parameter	Value	Unit	Description	Note
Addr	1 – 254		An unique address within the system	Set
bit/s	9600 19200	bps	Communication speed	Set
MeasInt	200 – 10000	ms	Minimum measurement response interval	Set
SyncRe	Sync Sync+Proc Msg Msg+Proc		ASDU6 response time mode	Set

Set = An editable parameter (password needed)

Table 8.9: Parameters for disturbance record reading

Parameter	Value	Unit	Description	Note
ASDU23	On Off		Enable record info message	Set
SmpIs/msg	1 – 25		Record samples in one message	Set
Timeout	10 – 10000	s	Record reading timeout	Set
Fault			Fault identifier number for IEC-103. Starts + trips of all stages.	
TagPos			Position of read pointer	
Chn			Active channel	
ChnPos			Channel read position	
Fault numbering				
Faults			Total number of faults	
GridFlts			Fault burst identifier number	
Grid			Time window to classify faults together to the same burst.	Set

Set = An editable parameter (password needed)

8.2.6 DNP 3.0

The relay supports communication using DNP 3.0 protocol. The following DNP 3.0 data types are supported:

- binary input
- binary input change
- double-bit input
- binary output
- analog input
- counters

Additional information can be obtained from the “DNP 3.0 Device Profile Document” and “DNP 3.0 Parameters.pdf”. DNP 3.0 communication is activated via menu selection. RS-485 interface is often used but also RS-232 and fibre optic interfaces are possible.

Table 8.10: Parameters

Parameter	Value	Unit	Description	Set
bit/s	4800 9600 (default) 19200 38400	bps	Communication speed	Set
Parity	None (default) Even Odd		Parity	Set
SlvAddr	1 – 65519		An unique address for the device within the system	Set
MstrAddr	1 – 65519 255 = default		Address of master	Set
LLTout	0 – 65535	ms	Link layer confirmation timeout	Set
LLRetry	1 – 255 1 = default		Link layer retry count	Set
APLTout	0 – 65535 5000 = default	ms	Application layer confirmation timeout	Set
CnfMode	EvOnly (default); All		Application layer confirmation mode	Set
DBISup	No (default); Yes		Double-bit input support	Set
SyncMode	0 – 65535	s	Clock synchronization request interval. 0 = only at boot	Set

Set = An editable parameter (password needed)

8.2.7 IEC 60870-5-101

The IEC 60870-5-101 standard is derived from the IEC 60870-5 protocol standard definition. In VAMP devices, IEC 60870-5-101 communication protocol is available via menu selection. The device works as a controlled outstation (slave) unit in unbalanced mode.

Supported application functions include process data transmission, event transmission, command transmission, general interrogation, clock synchronization, transmission of integrated totals, and acquisition of transmission delay.

For more information on IEC 60870-5-101 in VAMP devices, refer to the “IEC 101 Profile checklist & datalist.pdf” document.

Table 8.11: Parameters

Parameter	Value	Unit	Description	Note
bit/s	1200	bps	Bitrate used for serial communication.	Set
	2400			
	4800			
	9600			
Parity	None		Parity used for serial communication	Set
	Even			
	Odd			
LLAddr	1 – 65534		Link layer address	Set
LLAddrSize	1 – 2	Bytes	Size of Link layer address	Set
ALAddr	1 – 65534		ASDU address	Set
ALAddrSize	1 – 2	Bytes	Size of ASDU address	Set
IOAddrSize	2 – 3	Bytes	Information object address size. (3-octet addresses are created from 2-octet addresses by adding MSB with value 0.)	Set
COTsize	1	Bytes	Cause of transmission size	
TTFormat	Short		The parameter determines time tag format: 3-octet time tag or 7-octet time tag.	Set
	Full			
MeasFormat	Scaled		The parameter determines measurement data format: normalized value or scaled value.	Set
	Normalized			
DbandEna	No		Dead-band calculation enable flag	Set
	Yes			
DbandCy	100 – 10000	ms	Dead-band calculation interval	Set

Set = An editable parameter (password needed)

8.2.8 External I/O (Modbus RTU master)

External Modbus I/O devices can be connected to the relay using this protocol.

8.2.9 IEC 61850

IEC 61850 protocol is available with the optional communication module. IEC 61850 protocol can be used to read / write static data from the relay to receive events and to receive / send GOOSE messages to other relays.

IEC 61850 server interface is capable of

- Configurable data model: selection of logical nodes corresponding to active application functions
- Configurable pre-defined data sets
- Supported dynamic data sets created by clients
- Supported reporting function with buffered and unbuffered Report Control Blocks
- Sending analogue values over GOOSE
- Supported control modes:
 - direct with normal security
 - direct with enhanced security
 - select before operation with normal security
 - select before operation with enhanced security
- Supported horizontal communication with GOOSE: configurable GOOSE publisher data sets, configurable filters for GOOSE subscriber inputs, GOOSE inputs available in the application logic matrix

Additional information can be obtained from the separate documents “IEC 61850 conformance statement.pdf”, “IEC 61850 Protocol data.pdf” and “Configuration of IEC 61850 interface.pdf”.

8.2.10 EtherNet/IP

The device supports communication using EtherNet/IP protocol which is a part of CIP (Common Industrial Protocol) family. EtherNet/IP protocol is available with the optional inbuilt Ethernet port. The protocol can be used to read / write data from the device using request / response communication or via cyclic messages transporting data assigned to assemblies (sets of data).

For more detailed information and parameter lists for EtherNet/IP, refer to a separate application note “Application Note EtherNet/IP.pdf”.

For the complete data model of EtherNet/IP, refer to the document “Application Note DeviceNet and EtherNetIP Data Model.pdf”.

8.2.11 FTP server

The FTP server is available on VAMP IEDs equipped with an inbuilt or optional Ethernet card.

The server enables downloading of the following files from an IED:

- Disturbance recordings.
- The MasterICD and MasterICDEd2 files.

The MasterICD and MasterICDEd2 files are VAMP specific reference files that can be used for offline IEC61850 configuration.

The inbuilt FTP client in Microsoft Windows or any other compatible FTP client may be used to download files from the device.

Parameter	Value	Unit	Description	Note
Enable FTP server	Yes No		Enable or disable the FTP server.	Set
FTP password	Max 33 characters		Required to access the FTP server with an FTP client. Default is "config". The user name is always "VAMP".	Set
FTP max speed	1 – 10	KB/s	The maximum speed at which the FTP server will transfer data.	Set

8.2.12 HTTP server – Webset

The Webset HTTP configuration interface provides the option to configure the device with a standard web browser such as Internet Explorer, Mozilla Firefox, or Google Chrome. The feature is available when communication option C or D is in use.

A subset of the features of VAMPSET is available in the Webset interface. The group list and group view from VAMPSET are provided, and most groups, except the LOGIC and the MIMIC groups are configurable.

Parameter	Value	Description	Note
Enable HTTP svr	Yes; No	Enable or disable the HTTP server.	Set

9 Applications and configuration examples

The following chapters illustrate the functions in different protection applications.

The relays can be used for line/feeder protection of medium voltage networks with grounded, low-resistance grounded, isolated or a compensated neutral point. The relays have all the required functions to be applied as a backup relay in high voltage networks or to a transformer differential relay. In addition VAMP 300 includes all the required functions to be applied as motor protection relay for rotating machines in industrial protection applications.

The relays provide circuit-breaker control functionality, additional primary switching devices (earthing switches and disconnecter switches) can also be controlled from the relay HMI or the control or SCADA/automation system. Programmable logic functionality is also implemented in the relay for various applications e.g interlockings schemes.

9.1 Trip circuit supervision

Trip circuit supervision is used to ensure that the wiring from the protective device to a circuit-breaker is in order. This circuit is unused most of the time, but when a protection device detects a fault in the network, it is too late to notice that the circuit-breaker cannot be tripped because of a broken trip circuitry.

The digital inputs of the device can be used for trip circuit monitoring.

Also the closing circuit can be supervised, using the same principle.

9.1.1 Trip circuit supervision with one digital input

The benefits of this scheme is that only one digital inputs is needed and no extra wiring from the relay to the circuit breaker (CB) is needed. Also supervising a 24 Vdc trip circuit is possible.

The drawback is that an external resistor is needed to supervise the trip circuit on both CB positions. If supervising during the closed position only is enough, the resistor is not needed.

- The digital input is connected parallel with the trip contacts (Figure 9.1).
- The digital input is configured as Normal Closed (NC).

- The digital input delay is configured longer than maximum fault time to inhibit any superfluous trip circuit fault alarm when the trip contact is closed.
- The digital input is connected to a relay in the output matrix giving out any trip circuit alarm.
- The trip relay should be configured as non-latched. Otherwise, a superfluous trip circuit fault alarm will follow after the trip contact operates, and the relay remains closed because of latching.
- By utilizing an auxiliary contact of the CB for the external resistor, also the auxiliary contact in the trip circuit can be supervised.

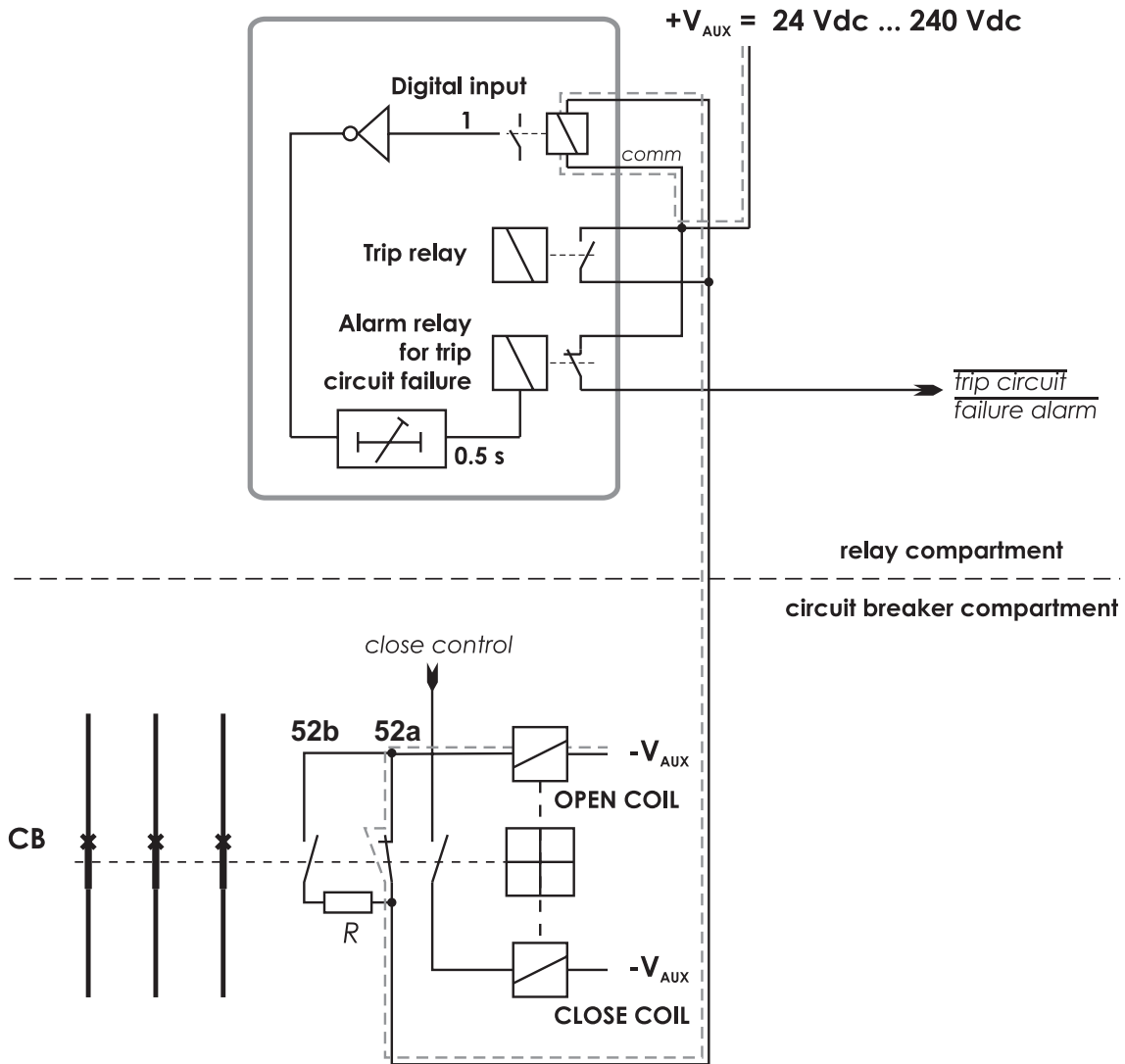

Figure 9.1: Trip circuit supervision using a single digital input and an external resistor R. The circuit-breaker is in the closed position. The supervised circuitry in this CB position is double-lined. The digital input is in active state when the trip circuit is complete. This is applicable for any digital inputs.

NOTE: The need for the external resistor R depends on the application and circuit breaker manufacturer's specifications.

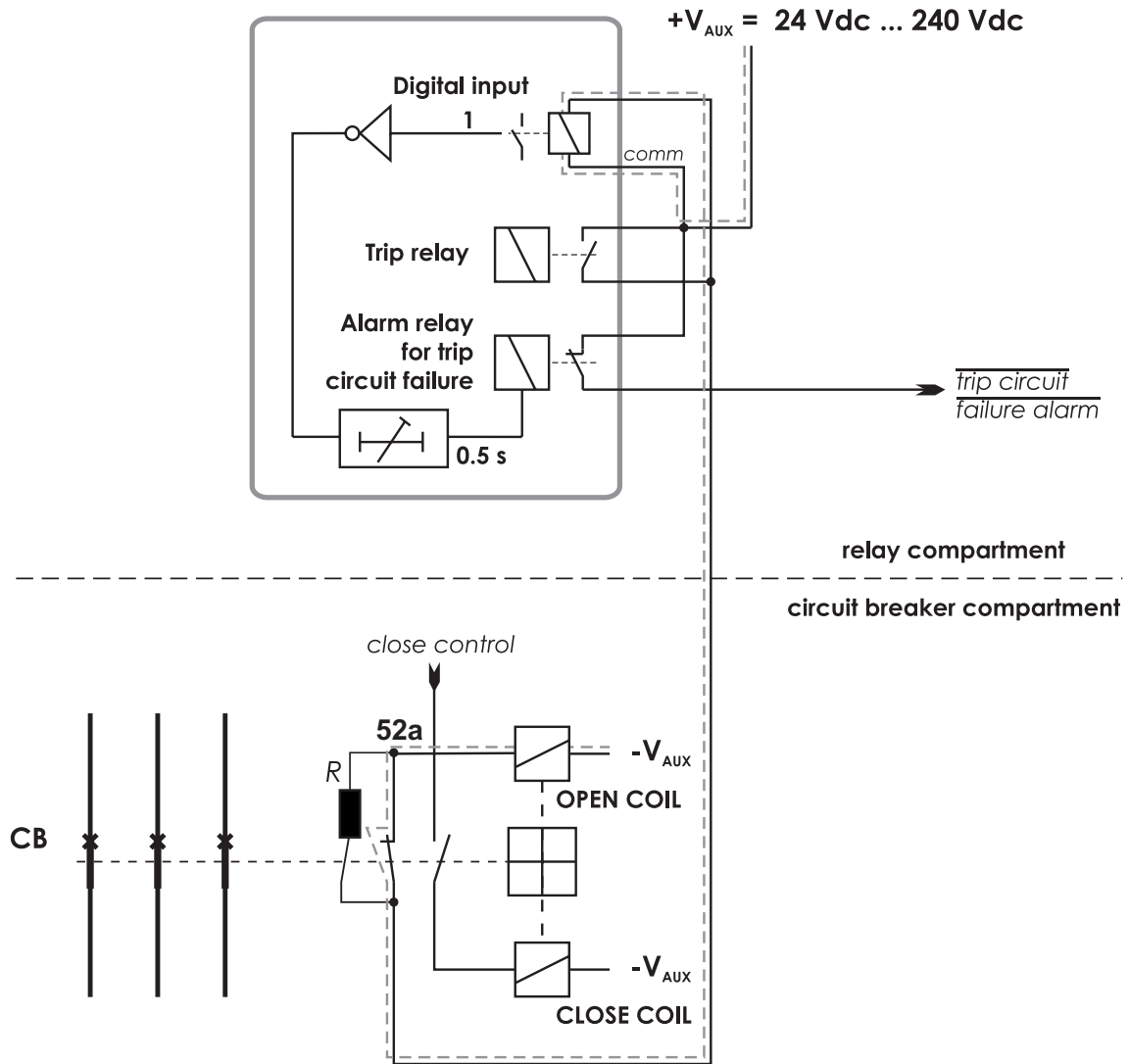

Figure 9.2: Alternative connection without using circuit breaker 52b auxiliary contacts. Trip circuit supervision using a single digital input and an external resistor R. The circuit-breaker is in the closed position. The supervised circuitry in this CB position is double-lined. The digital input is in active state when the trip circuit is complete. Alternative connection without using circuit breaker 52b auxiliary contacts. This is applicable for any digital inputs.

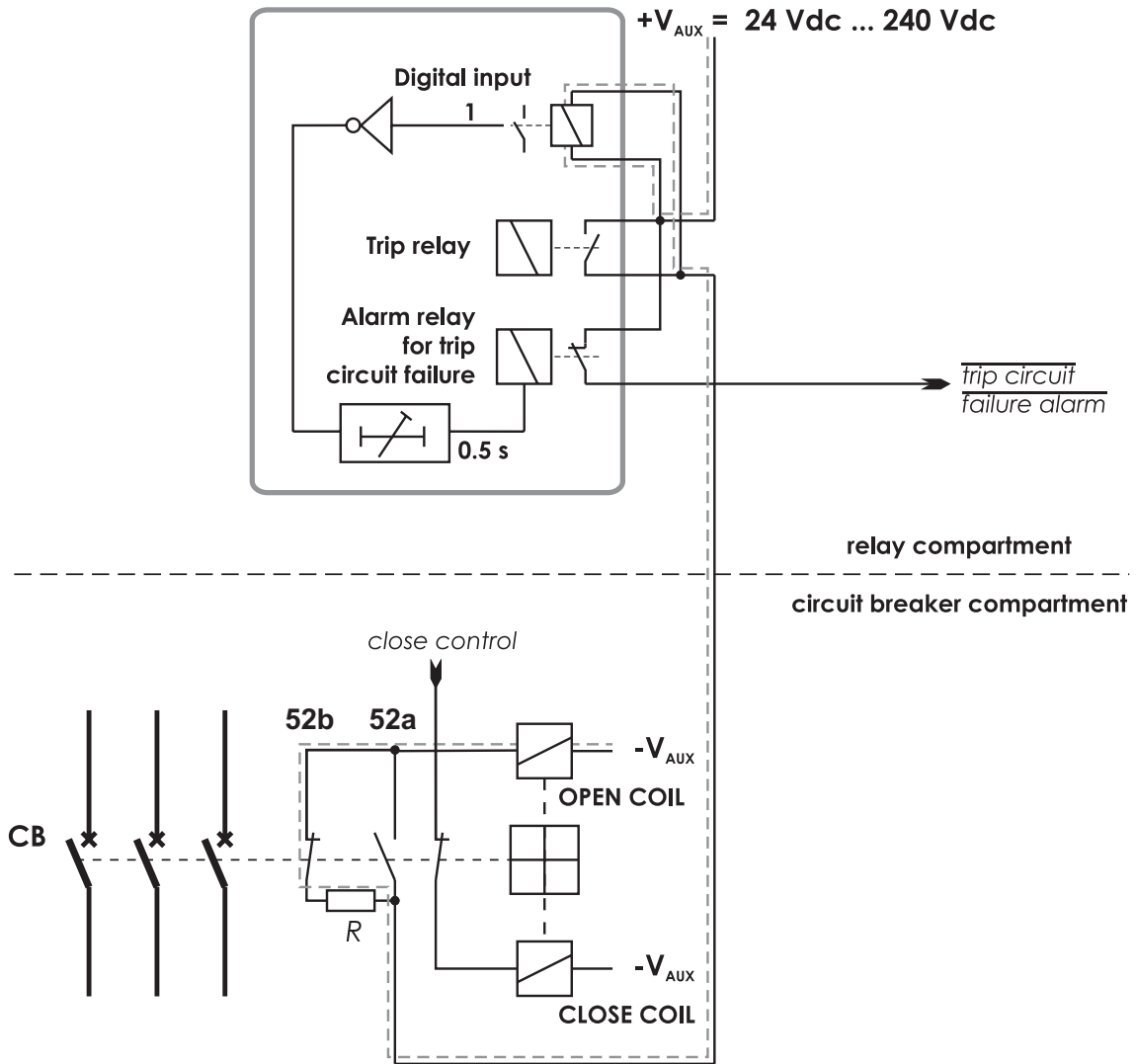

Figure 9.3: Trip circuit supervision using a single digital input, when the circuit breaker is in open position.

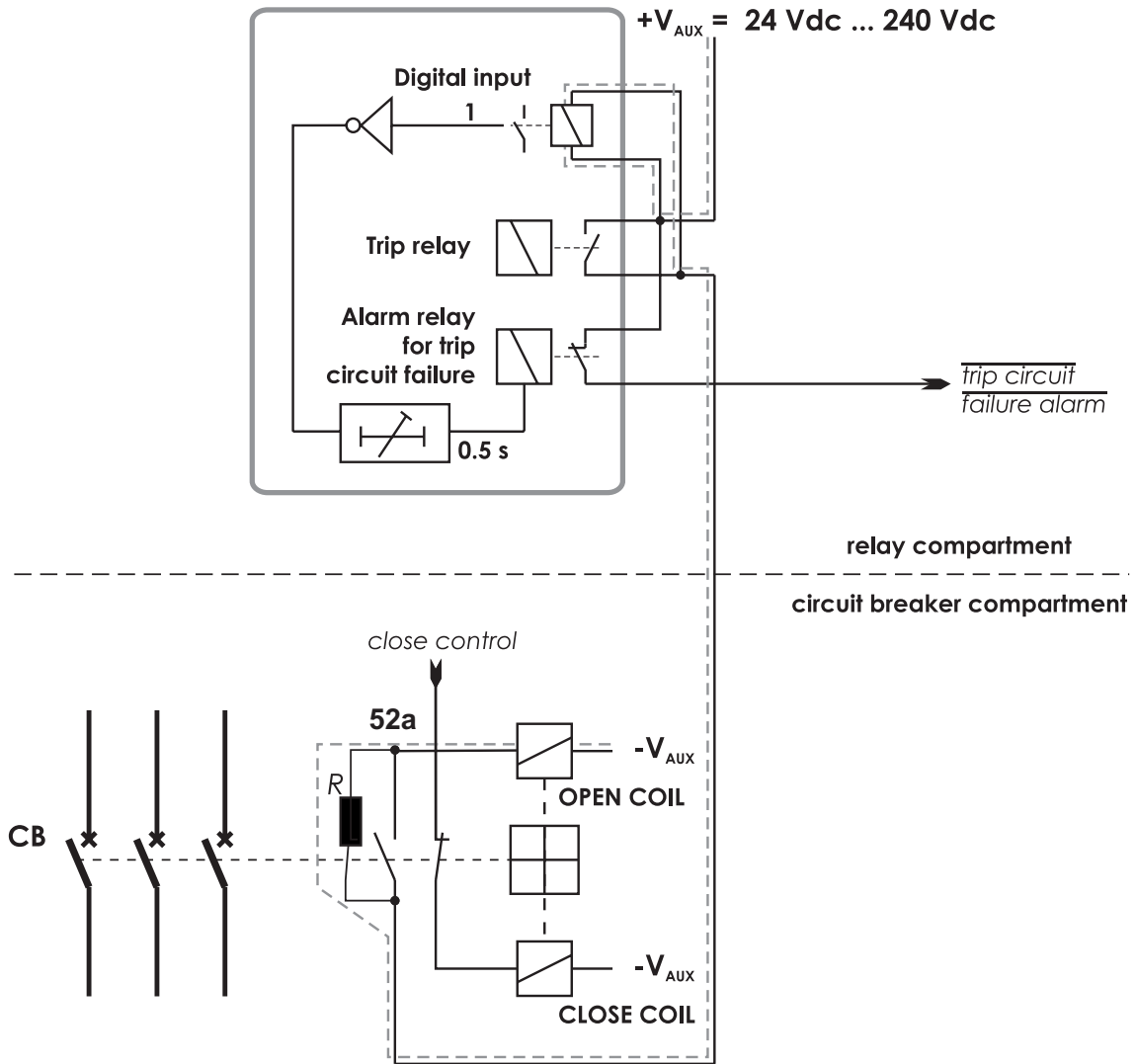

Figure 9.4: Alternative connection without using circuit breaker 52b auxiliary contacts. Trip circuit supervision using a single digital input, when the circuit breaker is in open position.

DIGITAL INPUTS

DIGITAL INPUTS								
Input	State	Polarity	Delay	On Event	Off Event	Alarm display	Counters	
1	0	NO	0.20 s	On	On	On	0	
2	0	NO	0.00 s	On	On	On	0	
3	0	NO	0.00 s	On	On	On	0	
4	0	NO	0.00 s	On	On	On	0	
5	0	NO	0.00 s	On	On	On	0	
6	0	NO	0.00 s	On	On	On	0	
7	0	NC	0.5 s	Off	Off	Off	0	

Figure 9.5: An example of digital input DI7 configuration for trip circuit supervision with one digital input.

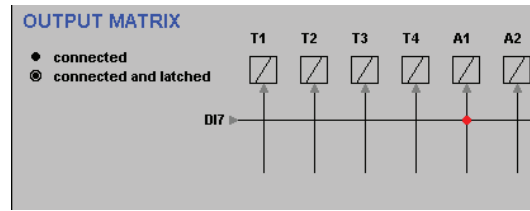

Figure 9.6: An example of output matrix configuration for trip circuit supervision with one digital input.

Example of dimensioning the external resistor R:

- $U_{AUX} =$ 110 Vdc - 20 % + 10%, Auxiliary voltage with tolerance
- $U_{DI} =$ 18 Vdc, Threshold voltage of the digital input
- $I_{DI} =$ 3 mA, Typical current needed to activate the digital input including a 1 mA safety margin.
- $P_{COIL} =$ 50 W, Rated power of the open coil of the circuit breaker. If this value is not known, 0 Ω can be used for the R_{COIL} .
- $U_{MIN} =$ $U_{AUX} - 20 \% = 88 \text{ V}$
- $U_{MAX} =$ $U_{AUX} + 10 \% = 121 \text{ V}$
- $R_{COIL} =$ $U_{AUX}^2 / P_{COIL} = 242 \text{ } \Omega$.

The external resistance value is calculated using Equation 9.1.

Equation 9.1:

$$R = \frac{U_{MIN} - U_{DI} - I_{DI} \cdot R_{Coil}}{I_{DI}}$$

$$R = (88 - 18 - 0.003 \times 242) / 0.003 = 23.1 \text{ k}\Omega$$

(In practice the coil resistance has no effect.)

By selecting the next smaller standard size we get **22 kΩ**.

The power rating for the external resistor is estimated using Equation 9.2 and Equation 9.3. The Equation 9.2 is for the CB open situation including a 100 % safety margin to limit the maximum temperature of the resistor.

Equation 9.2:

$$P = 2 \cdot I_{DI}^2 \cdot R$$

$$P = 2 \times 0.003^2 \times 22000 = 0.40 \text{ W}$$

Select the next bigger standard size, for example **0.5 W**.

When the trip contacts are still closed and the CB is already open, the resistor has to withstand much higher power (Equation 9.3) for this short time.

Equation 9.3:

$$P = \frac{U_{MAX}^2}{R}$$

$$P = 121^2 / 22000 = 0.67 \text{ W}$$

A 0.5 W resistor will be enough for this short time peak power, too. However, if the trip relay is closed for longer time than a few seconds, a 1 W resistor should be used.

9.1.2 Trip circuit supervision with two digital inputs

The benefits of this scheme is that no external resistor is needed.

The drawbacks are, that two digital inputs are needed and two extra wires from the relay to the CB compartment is needed. Additionally the minimum allowed auxiliary voltage is 48 Vdc, which is more than twice the threshold voltage of the digital input, because when the CB is in open position, the two digital inputs are in series.

- The first digital input is connected parallel with the auxiliary contact of the open coil of the circuit breaker.
- Another auxiliary contact is connected in series with the circuitry of the first digital input. This makes it possible to supervise also the auxiliary contact in the trip circuit.
- The second digital input is connected in parallel with the trip contacts.
- Both inputs are configured as normal closed (NC).
- The user's programmable logic is used to combine the digital input signals with an AND port. The delay is configured longer than maximum fault time to inhibit any superfluous trip circuit fault alarm when the trip contact is closed.
- The output from the logic is connected to a relay in the output matrix giving out any trip circuit alarm.

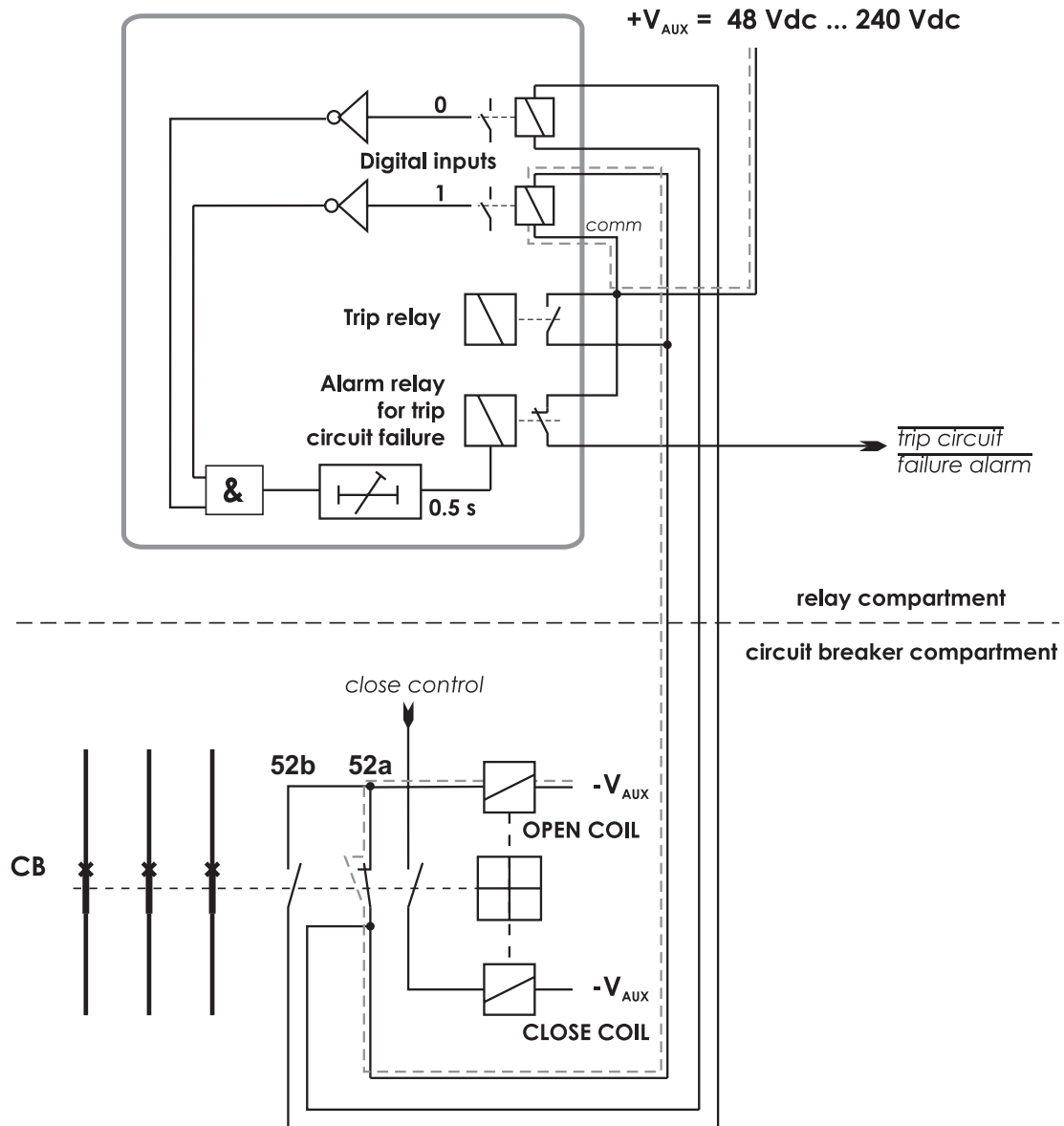

Figure 9.7: Trip circuit supervision with two digital inputs. The CB is closed. The supervised circuitry in this CB position is double-lined. The digital input is in active state when the trip circuit is complete. This is applicable for all digital inputs.

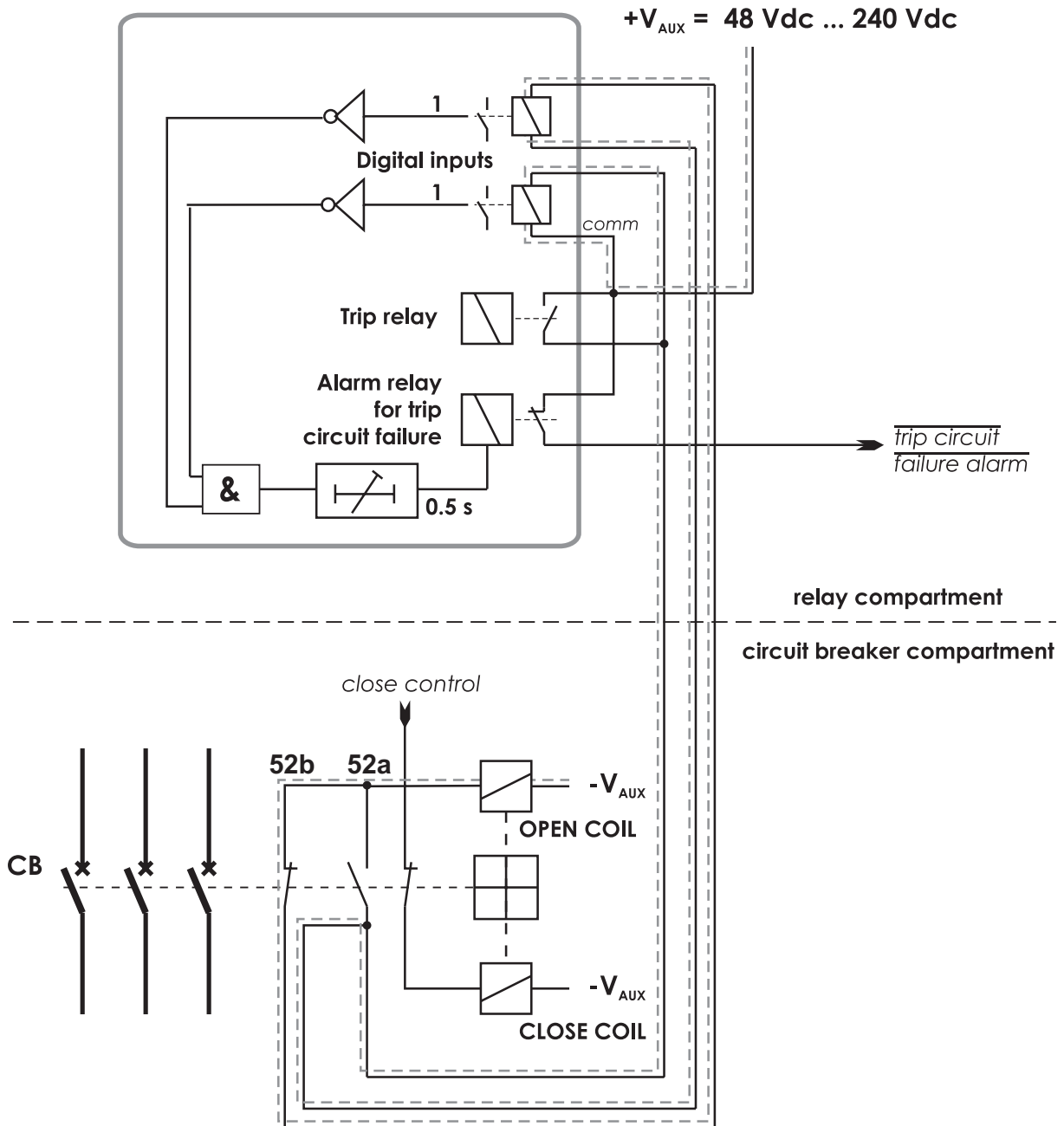

Figure 9.8: Trip circuit supervision with two digital inputs. The CB is in the open position. The two digital inputs are now in series.

DIGITAL INPUTS

Input	State	Polarity	Delay	On Event	Off Event	Alarm display	Counters
1	0	NO	0.00 s	On	On	On	0
2	0	NO	0.00 s	On	On	On	0
3	0	NO	0.00 s	On	On	On	0
4	0	NO	0.00 s	On	On	On	0
5	0	NO	0.00 s	On	On	On	0
6	0	NO	0.00 s	On	On	On	0
7	0	NC	0.00 s	Off	Off	Off	0
8	0	NO	0.00 s	On	On	On	0
9	0	NO	0.00 s	On	On	On	0
10	0	NO	0.00 s	On	On	On	0
11	0	NO	0.00 s	On	On	On	0
12	0	NO	0.00 s	On	On	On	0
13	0	NC	0.00 s	Off	Off	Off	0

Figure 9.9: An example of digital input configuration for trip circuit supervision with two digital inputs DI7 and DI13.

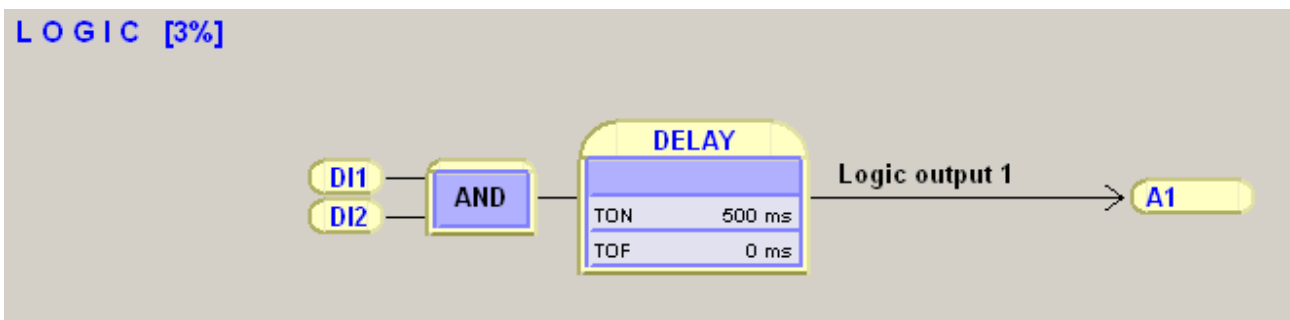

Figure 9.10: An example of logic configuration for trip circuit supervision with two digital inputs DI1 and DI2.

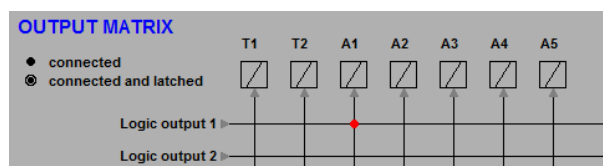

Figure 9.11: An example of output matrix configuration for trip circuit supervision with two digital inputs.

9.2 Rotor earth-fault protection application

The rotor earth-fault can be utilized with an injection source connected between earth and one side of the field circuit through capacitive coupling. The field circuit is subjected to an alternating potential at substantially the same level throughout. An earth fault anywhere in the field system will give rise to a current that is detected by protection relay.

This scheme is suitable for generators that incorporate brushes in the main generator field winding.

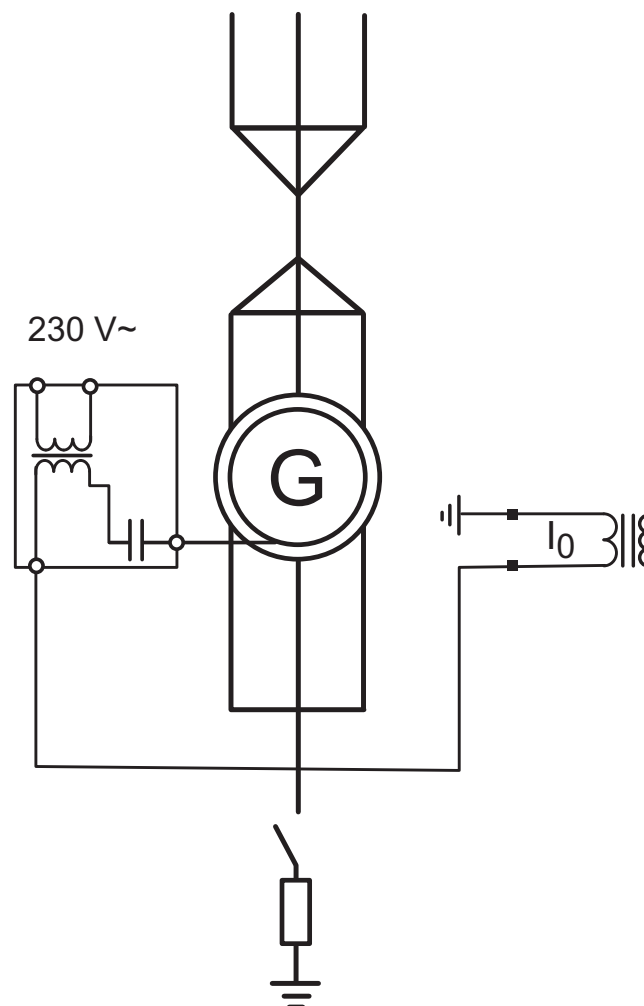
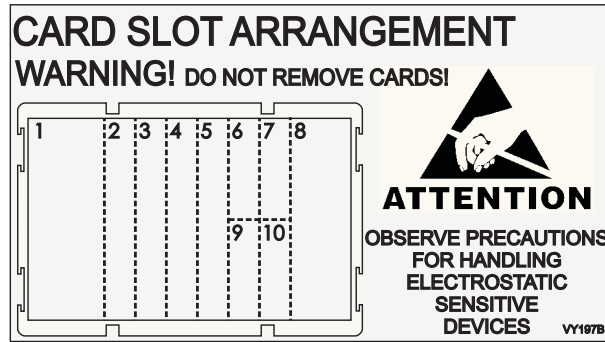

Figure 9.12: Rotor earth-fault protection principle of field circuit by a.c. injection

10 Connections

The VAMP 300G IED has fixed combination of analog interface, power supply, DI/DO, communication and arc flash protection cards as per chosen order code. Do not remove hardware from IED's card slot in any circumstances.



10.1 I/O cards and optional I/O cards

The configuration of the device can be checked from local HMI or VAMPSET menu called “Slot” or “SLOT INFO”. This contains “Card ID” which is the name of the card used by the device software.

SLOT INFO

Slot	Card ID	Trace ID	Status
1	Pwr 80-265		OK
2	3xS+F+BI+BO		OK
3	6xDI+4xDO		OK
4	10xDO		OK
5	None	-	-
6	4xDO		OK
7	None	-	-
8	3L+Io5/1+4U		OK
9	RS232+RJ45		OK
10	None	-	-
Display	128x64		OK

Figure 10.1: An example of showing the hardware configuration by VAMPSET

10.2 Supply voltage cards

Auxiliary voltage

External auxiliary voltage U_{AUX} (110 – 240 V ac / dc, or optionally 24 – 48 V dc) of the device is connected to the pins 1/C, D/1:1 – 2.

NOTE: When optional 24 – 48 V dc power module is used the polarity is as follows: 1/D/2:2 positive (+), 1/D/2:1 negative (-).



Figure 10.2: Example of supply voltage card Power C 110-240

Table 10.1: Supply voltage card Power C 110-240 & Power D 24-48

Pin No.	Symbol	Description
20	T12	Heavy duty trip relay 12 for arc protection
19	T12	Heavy duty trip relay 12 for arc protection
18	T11	Heavy duty trip relay 11 for arc protection
17	T11	Heavy duty trip relay 11 for arc protection
16	T10	Heavy duty trip relay 10 for arc protection
15	T10	Heavy duty trip relay 10 for arc protection
14	T9	Heavy duty trip relay 9 for arc protection
13	T9	Heavy duty trip relay 9 for arc protection
12	T1	Heavy duty trip relay 1 for arc protection
11	T1	Heavy duty trip relay 1 for arc protection
10	A1 NO	Signal relay 1, normal open connector
9	A1 NC	Signal relay 1, normal closed connector
8	A1 COMMON	Signal relay 1, common connector
7	SF NO	Service status output, normal open
6	SF NC	Service status output, normal closed
5	SF COMMON	Service status output, common
4		No connection
3		No connection
2	L / + / ~	Auxiliary voltage
1	N / - / ~	Auxiliary voltage

⚠ DANGER

HAZARD OF ELECTRICAL SHOCK

Always connect the protective grounding before connecting the power supply.

Failure to follow these instructions will result in death or serious injury.

10.3 Analogue measurement cards

10.3.1 "C = 3L(5A) + 4U + 2I₀(5+1A)"

This card contains connections for current transformers for measuring of the phase currents L1 – L3 and two residual current I₀, and four voltage transformers for measuring of the U₀, ULL or ULN.

Following analogue card can be used in capacitor bank (C) and generator (G) applications. IED is able to measure three phase currents, two residual currents. IED also measures up to four voltage signals line to line, line to neutral, zero sequence voltage and voltage from another side (synchro-check). See voltage modes selection below:

- 3LN+U₀, 3LN+LL_Y, 3LN+LN_Y
- 2LL+U₀+LL_Y, 2LL+U₀+LN_Y
- LL+U₀+LL_Y+LL_Z, LN+U₀+LN_Y+LN_Z

Table 10.2: Terminal pins 8/C/1:1 – 12

Pin No.	Symbol	Description
1	IL1 (S1)	Phase current L1 (S1)
2	IL1 (S2)	Phase current L1 (S2)
3	IL2 (S1)	Phase current L2 (S1)
4	IL2 (S2)	Phase current L2 (S2)
5	IL3 (S1)	Phase current L3 (S1)
6	IL3 (S2)	Phase current L3 (S2)
7	I ₀₁ /5A	Residual current I ₀₁ 5A
8	I ₀₁ /5A	Residual current I ₀₁ 5A
9	I ₀₂ /1A	Residual current I ₀₂ 1A
10	I ₀₂ /1A	Residual current I ₀₂ 1A
11	U ₀ /ULL/ULN	U ₀ (da)/ ULL (a)/ ULN (a)
12	U ₀ /ULL/ULN	U ₀ (dn)/ ULL (b)/ ULN (n)

Table 10.3: Terminal pins 8/C/2:1 – 6

Pin No.	Symbol	Description
1	ULL/ULN	Voltage ULL (a) /ULN (a)
2	ULL/ULN	Voltage ULL (b) /ULN (n)
3	ULL/ULN	Voltage ULL (a) /ULN (a)
4	ULL/ULN	Voltage ULL (b) /ULN (n)
5	ULL/ULN	Voltage ULL (a) /ULN (a)
6	ULL/ULN	Voltage ULL (b) /ULN (n)

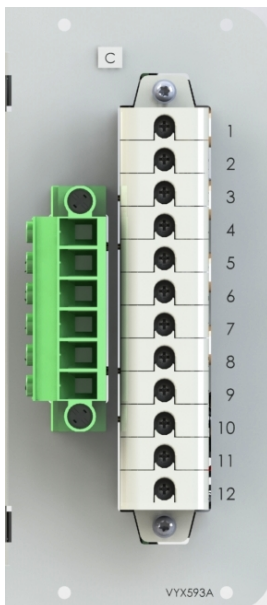

Figure 10.3: Analogue measurement card "C"

10.3.2 "D = 3L(5A) + 4U + 2I₀ (1+0.2A)"

This card contains connections for current transformers for measuring of the phase currents L1 – L3 and two residual current I₀, and four voltage transformers for measuring of the U₀, ULL or ULN.

Following analogue card can be used in capacitor bank (C), feeder (F), generator (G), line (L) and motor (M) applications. IED is able to measure three phase currents, two residual currents. IED also measures up to four voltage signals line to line, line to neutral, zero sequence voltage and voltage from another side (synchro-check). See voltage modes selection below:

- 3LN+U₀, 3LN+LL_γ, 3LN+LN_γ
- 2LL+U₀+LL_γ, 2LL+U₀+LN_γ
- LL+U₀+LL_γ+LL_z, LN+U₀+LN_γ+LN_z

Table 10.4: Terminal pins 8/D/1:1 – 12

Pin No.	Symbol	Description
1	IL1 (S1)	Phase current L1 (S1)
2	IL1 (S2)	Phase current L1 (S2)
3	IL2 (S1)	Phase current L2 (S1)
4	IL2 (S2)	Phase current L2 (S2)
5	IL3 (S1)	Phase current L3 (S1)
6	IL3 (S2)	Phase current L3 (S2)
7	I ₀₁ /1A	Residual current I ₀₁ 1A
8	I ₀₁ /1A	Residual current I ₀₁ 1A
9	I ₀₂ /0.2A	Residual current I ₀₂ 0.2A
10	I ₀₂ /0.2A	Residual current I ₀₂ 0.2A
11	U ₀ /ULL/ULN	U ₀ (da)/ ULL (a)/ ULN (a)
12	U ₀ /ULL/ULN	U ₀ (dn)/ ULL (b)/ ULN (n)

Table 10.5: Terminal pins 8/D/2:1 – 6

Pin No.	Symbol	Description
1	ULL/ULN	Voltage ULL (a) /ULN (a)
2	ULL/ULN	Voltage ULL (b) /ULN (n)
3	ULL/ULN	Voltage ULL (a) /ULN (a)
4	ULL/ULN	Voltage ULL (b) /ULN (n)
5	ULL/ULN	Voltage ULL (a) /ULN (a)
6	ULL/ULN	Voltage ULL (b) /ULN (n)

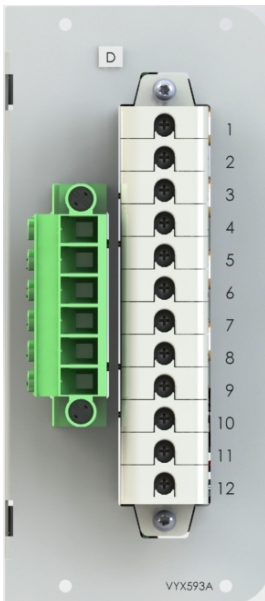

Figure 10.4: Analogue measurement card "D"

10.3.3 "W = 3L(1A) + 4U + 2I₀(5+1A)"

This card contains connections for current transformers for measuring of the phase currents L1 – L3 and two residual current I₀, and four voltage transformers for measuring of the U₀, ULL or ULN.

Following analogue card can be used in capacitor bank (C) and generator (G) applications. IED is able to measure three phase currents, two residual currents. IED also measures up to four voltage signals line to line, line to neutral, zero sequence voltage and voltage from another side (synchro-check). See voltage modes selection below:

- 3LN+U₀, 3LN+LL_Y, 3LN+LN_Y
- 2LL+U₀+LL_Y, 2LL+U₀+LN_Y
- LL+U₀+LL_Y+LL_Z, LN+U₀+LN_Y+LN_Z

Table 10.6: Terminal pins 8/W/1:1 – 12

Pin No.	Symbol	Description
1	IL1 (S1)	Phase current L1 (S1)
2	IL1 (S2)	Phase current L1 (S2)
3	IL2 (S1)	Phase current L2 (S1)
4	IL2 (S2)	Phase current L2 (S2)
5	IL3 (S1)	Phase current L3 (S1)
6	IL3 (S2)	Phase current L3 (S2)
7	I ₀₁ /5A	Residual current I ₀₁ 5A
8	I ₀₁ /5A	Residual current I ₀₁ 5A
9	I ₀₂ /1A	Residual current I ₀₂ 1A
10	I ₀₂ /1A	Residual current I ₀₂ 1A
11	U ₀ /ULL/ULN	U ₀ (da)/ ULL (a)/ ULN (a)
12	U ₀ /ULL/ULN	U ₀ (dn)/ ULL (b)/ ULN (n)

Table 10.7: Terminal pins 8/W/2:1 – 6

Pin No.	Symbol	Description
1	ULL/ULN	Voltage ULL (a) /ULN (a)
2	ULL/ULN	Voltage ULL (b) /ULN (n)
3	ULL/ULN	Voltage ULL (a) /ULN (a)
4	ULL/ULN	Voltage ULL (b) /ULN (n)
5	ULL/ULN	Voltage ULL (a) /ULN (a)
6	ULL/ULN	Voltage ULL (b) /ULN (n)

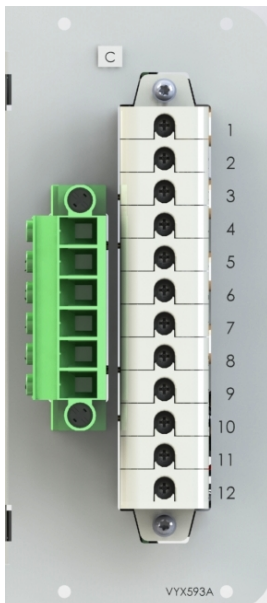

Figure 10.5: Analogue measurement card "W"

10.3.4 “ $T = 3 \times I (5/1A) + I_0 (5/1A)$ ”

This card contains connections current measurement transformers for measuring of the phase currents L1, L2 and L3 and residual current I_0 .

Following analogue card can be used in generator (G) applications. Totally IED is able to measure six phase currents, three residual currents and additionally four voltages.

Table 10.8: Pins 4/A/1:1 – 12

Pin No.	Symbol	Description
1	I'L1	Phase current I'L1 (S1), common for 1A and 5A
2	I'L1 / 5A	Phase current I'L1 (S2)
3	I'L1 / 1A	Phase current I'L1 (S2)
4	I'L2	Phase current I'L2 (S1), common for 1A and 5A
5	I'L2 / 5A	Phase current I'L2 (S2)
6	I'L2 / 1A	Phase current I'L2 (S2)
7	I'L3	Phase current I'L3 (S1), common for 1A and 5A
8	I'L3 / 5A	Phase current I'L3 (S2)
9	I'L3 / 1A	Phase current I'L3 (S2)
10	I'o1	Residual current I'o1 (S1), common for 1A and 5A
11	I'o1 / 5A	Residual current I'o1 (S2)
12	I'o1 / 1A	Residual current I'o1 (S2)

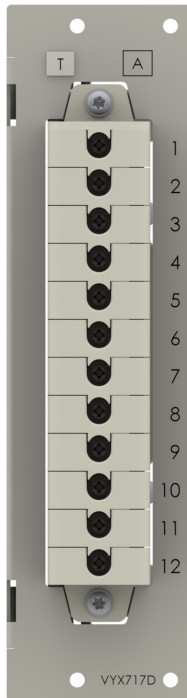

Figure 10.6: Analogue measurement card "T"

⚠ DANGER

HAZARD OF ELECTRICAL SHOCK

Do not open the secondary circuit of a live current transformer.

Disconnecting the secondary circuit of a live current transformer may cause dangerous overvoltages.

Failure to follow these instructions will result in death or serious injury.

10.3.5 Voltage measuring modes correlation for C, D and W analogue measurement cards

U1, U2, U3 and U4 are voltage channels for the IED, where U4 is located in terminal 8/C or D/1 and the remaining voltage channels are interfaced with 8/C or D/2.

The physical voltage transformer connection in the VAMP 300G IED depends on the used voltage transformer connection mode. This setting is made in scalings setting view. See Table 10.9.

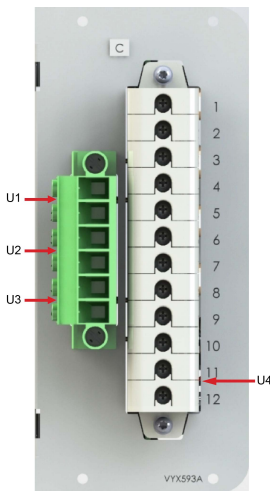

Table 10.9: Correlation between voltage measuring mode and physical voltage input in Terminals 8/C/1 and 2, 8/D/1 and 2, 8/W/1 and 2

Terminal	8/C/2, 8/D/2 and 8/W/2						8/C/1, 8/D/1 and 8/W/1	
	1	2	3	4	5	6	11	12
Voltage channel	U1		U2		U3		U4	
Mode / Used voltage								
3LN	UL1		UL2		UL3		Not in use	
3LN+U ₀	U12		U23		U ₀		U ₀	
2LL+U ₀	U12		U23		U ₀		Not in use	

Figure 10.7: Example of Terminal 8/C/1 and 2

10.4 I/O cards

10.4.1 I/O card “G = 6DI+4DO”

This card provides 6 digital inputs and 4 relays outputs. The threshold level is selectable by the last digit of the ordering code.

6xDI+4xDO option card is equipped with six dry digital inputs with hardware selectable activation/threshold voltage and four trip contacts. Input and output contacts are normally open.

Table 10.10: Slots 2 – 5/G/1:1 – 20



Pin No.	Symbol	Description
20	Tx	Trip relay
19		
18	Tx	Trip relay
17		
16	Tx	Trip relay
15		
14	Tx	Trip relay
13		
12	DIx	Digital input
11		
10	DIx	Digital input
9		
8	DIx	Digital input
7		
6	DIx	Digital input
5		
4	DIx	Digital input
3		
2	DIx	Digital input
1		

NOTE: Digital inputs are polarity free which means that the user can freely choose "-" and "+" terminals to each digital input.

10.4.2 I/O card “I = 10DI”

This card provides 10 digital inputs. The threshold level is selectable by the last digit of the ordering code.

Table 10.11: Slots 2 – 5//1:1 – 20





Pin No.	Symbol	Description
20	DIx	Digital input
19		
18	DIx	Digital input
17		
16	DIx	Digital input
15		
14	DIx	Digital input
13		
12	DIx	Digital input
11		
10	DIx	Digital input
9		
8	DIx	Digital input
7		
6	DIx	Digital input
5		
4	DIx	Digital input
3		
2	DIx	Digital input
1		

NOTE: Digital inputs are polarity free which means that the user can freely choose "-" and "+" terminals to each digital input.



10.5 Communication cards

The communication card types and their pin assignments are introduced in the following table.

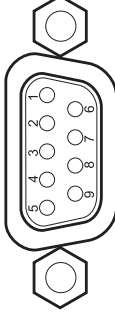
Table 10.12: Communication option modules and their pin numbering

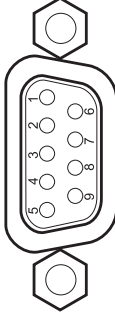
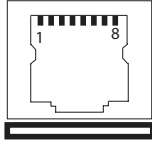
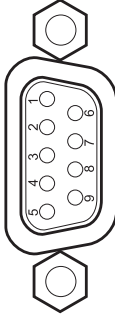
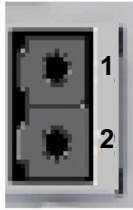
Type	Communication ports	Signal levels	Connectors	Pin usage
FibrePP (Slot 6 and 9)	Plastic fibre interface COM 1 port (if Slot 6 card) COM 3 port (if Slot 9 card)		Versatile Link fiber 	
FibreGG (Slot 6 and 9)	Glass fibre interface (62.5/125 µm) COM 1 port (if Slot 6 card) COM 3 port (if Slot 9 card)		ST 	
232 (Slot 9)	COM 3 / COM 4	RS-232	D-connector 	1 = TX COM 4 2 = TX COM 3 3 = RX COM 3 4 = IRIG-B 5 = IRIG-B GND 6 = 7 = GND 8 = RX COM 4 9 = +12V

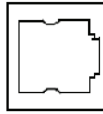
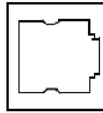
Type	Communication ports	Signal levels	Connectors	Pin usage
232+Eth RJ (Slot 9)	COM 3 / COM 4	RS-232	D-connector 	1 = TX COM 4 2 = TX COM 3 3 = RX COM 3 4 = IRIG-B 5 = IRIG-B GND 6 = 7 = GND 8 = RX COM 4 9 = +12V
	ETHERNET	ETHERNET 100Mbps	RJ-45 	1 = Transmit + 2 = Transmit - 3 = Receive + 4 = 5 = 6 = Receive - 7 = 8 =
232+Eth LC (Slot 9)	COM 3 / COM 4	RS-232	D-connector 	1 = TX COM 4 2 = TX COM 3 3 = RX COM 3 4 = IRIG-B 5 = IRIG-B GND 6 = 7 = GND 8 = RX COM 4 9 = +12V
	ETHERNET	Light 100Mbps	LC fiber connector 	1 = Receive 2 = Transmit

Type	Communication ports	Signal levels	Connectors	Pin usage
2EthRJ (Slot 9)	100Mbps Ethernet interface with IEC 61850	ETHERNET 100Mbps	2 x RJ-45  	1=Transmit+ 2=Transmit- 3=Receive+ 4= 5= 6=Receive- 7= 8=
2EthLC (Slot 9)	100 Mbps Ethernet fibre interface with IEC 61850	Light 100Mbps	2 x LC  	LC-connector from top: -Port 2 Tx -Port 2 Rx -Port 1 Tx -Port 1 Rx

NOTE: When communication option module of type B, C or D is used in slot 9, serial ports COM 3 / COM 4 are available.

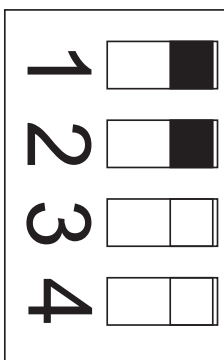

Dip switch number	Switch position	Function
Fibre optics		
1	Left	Echo off
1	Right	Echo on
2	Left	Light on in idle state
2	Right	Light off in idle state
3	Left	Not applicable
3	Right	Not applicable
4	Left	Not applicable
4	Right	Not applicable

Figure 10.8: Dip switches in optic fibre options.

10.5.1 COM 3 – COM 4 ports

COM 3 – COM 4 PORT are ports for serial communication protocols. The type of the physical interface on these ports depends on the type of the selected communication option module. The use of some protocols may require a certain type of option module. The parameters for these ports are set via local HMI or with VAMPSET in menus COM 3 PORT – COM 4 PORT.

Communication information is normally sent to control system (SCADA) but it is also possible to use certain communication related notifications internally for example alarming. This is can be done for example via logic and different matrixes.

OUTPUT MATRIX

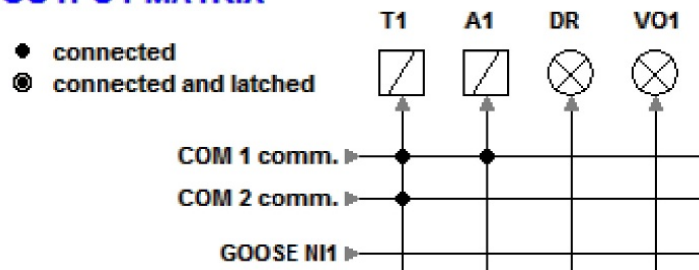
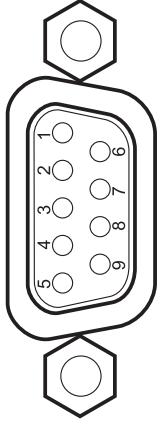

Figure 10.9: Communication related notifications can be connected to trip contacts or other similar purpose in "output matrix" menu.

Table 10.13: COM 3 port

Type	External module	Order code	Cable / order code	Typically used protocols
232+00 or 232+Eth RJ or 232+Eth LC (Slot 9)	None	None	None	-None -IEC-101 -IRIG-B -GetSet
	VSE-009	VSE009	None	-None -DeviceNet
	VIO12-AB and VSE-002	VIO 12 AB VSE002	None	-None -ExternalIO
	VIO12-AC and VSE-002	VIO 12 AC VSE002	None	-None -ExternalIO
	VIO12-AD and VSE-002	VIO 12 AD VSE002	None	-None -ExternalIO
	VSE-001	VSE001	None	-None -IEC-103 -ModbusSlv -SpaBus
	VSE-002	VSE002	None	-None -IEC-103 -ModbusSlv -SpaBus -DNP3
	VPA-3CG	VPA3CG	VX068	-None -ProfibusDP

To be able to use COM 4 port, RS-232 communication interface (Option B, C or D) has to be split in to two by using VX067 cable. When VX-067 cable is connected below mentioned protocols can be used in COM 4 port:

Table 10.14: COM 4 port

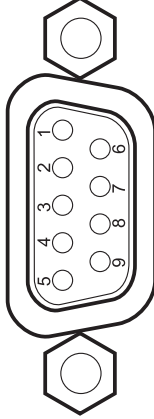
Type	External module	Order code	Cable / order code	Typically used protocols
232+00 or 232+Eth RJ or 232+Eth LC +VX067 (Split cable) (Slot 9) 	None	None	None	-None -IEC-101 -IRIG-B -GetSet
	VSE-009	VSE-009	None	-None -DeviceNet
	VIO12-AB and VSE-002	VIO 12 AB VSE002	None	-None -ExternalIO
	VIO12-AC and VSE-002	VIO 12 AC VSE002	None	-None -ExternalIO
	VIO12-AD and VSE-002	VIO 12 AD VSE002	None	-None -ExternalIO
	VSE-001	VSE001	None	-None -IEC-103 -ModbusSlv -SpaBus
	VSE-002	VSE002	None	-None -IEC-103 -ModbusSlv -SpaBus -DNP3
	VPA-3CG	VPA3CG	VX068	-None -ProfibusDP

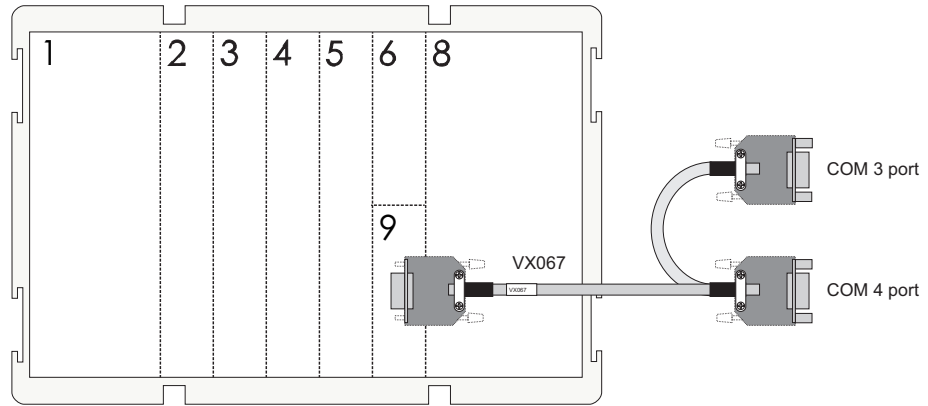

Figure 10.10: To be able to use COM 3 and COM 4 ports, VX067 must be used on the D-connector of slot 9 option card.

NOTE: It is possible to have up to 2 serial communication protocols simultaneously but restriction is that same protocol can be used only once.

Protocol configuration menu contains selection for the protocol, port settings and message/error/timeout counters.

PROTOCOL CONFIGURATION

COM 3 PORT	
COM 3 port protocol	None
-	9600/8N1
Message counter	0
Error counter	0
Timeout counter	0

COM 4 PORT	
COM 4 port protocol	None
-	9600/8N1
Message counter	0
Error counter	0
Timeout counter	0

Figure 10.11: Protocols can be enabled in “protocol configuration” menu. Only serial communication protocols are valid with RS-232 interface.

Table 10.15: Parameters

Parameter	Value	Unit	Description	Note
Protocol			Protocol selection for COM port	Set
	None		-	
	SPA-bus		SPA-bus (slave)	
	ProfibusDP		Interface to Profibus DB module VPA 3CG (slave)	
	ModbusSlv		Modbus RTU slave	
	IEC-103		IEC-60870-5-103 (slave)	
	ExternalIO		Modbus RTU master for external I/O-modules	
	IEC 101		IEC-608670-5-101	
	DNP3		DNP 3.0	
	DeviceNet		Interface to DeviceNet module VSE 009	
	GetSet		Communicationi protocola for VAMPSET interface	
Msg#	0 – 2 ³² - 1		Message counter since the device has restarted or since last clearing	Clr
Errors	0 – 2 ¹⁶ - 1		Protocol interruption since the device has restarted or since last clearing	Clr
Tout	0 – 2 ¹⁶ - 1		Timeout interruption since the device has restarted or since last clearing	Clr
	speed/DPS		Display of current communication parameters. speed = bit/s D = number of data bits P = parity: none, even, odd S = number of stop bits	1.

Set = An editable parameter (password needed). Clr = Clearing to zero is possible.

1. The communication parameters are set in the protocol specific menus. For the local port command line interface the parameters are set in configuration menu.

10.6 Local port (Front panel)

The relay has a USB-connector in the front panel

Protocol for the USB port

The front panel USB port is always using the command line protocol for VAMPSET.

The protocol is an ASCII character protocol called “GetSet”. The speed of the interface is defined in CONF/DEVICE SETUP menu from the local HMI. The default settings for the relay are 38400/8N1.

Physical interface

The physical interface of this port is USB.

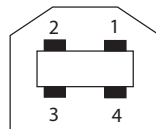

Figure 10.12: Pin numbering of the front panel USB type B connector

Pin	Signal name
1	VBUS
2	D-
3	D+
4	GND
Shell	Shield

It is possible to change the bit rate of front USB port. This setting is visible only on local display of the device. Bit rate can be set between 1200 – 187500. This changes the bit rate of the IED, VAMPSET bit rate has to be set separately. If bit rate in setting tool is incorrect it takes longer time to establish the communication.

NOTE: Use same bit rate in the device and VAMPSET setting tool.

10.7 External option modules

10.7.1 VSE-001 fiber optic interface module

External fiber optic module VSE-001 is used to connect the device to a fiber optic loop or a fiber optic star. Variety includes four different types of serial fiber optic modules.

- VSE001PP (Plastic - plastic)
- VSE001GG (Glass - glass)
- VSE001GP (Glass - plastic)
- VSE001PG (Plastic - glass)

Modules provide serial communication link up to 1 km with VSE 001 GG. With serial fibre interface module it is possible to have following serial protocols in use.

- None
- IEC-103
- ModbusSlv
- SpaBus

The power for the module is taken from pin 9 of the D-connector or from an external power supply interface.

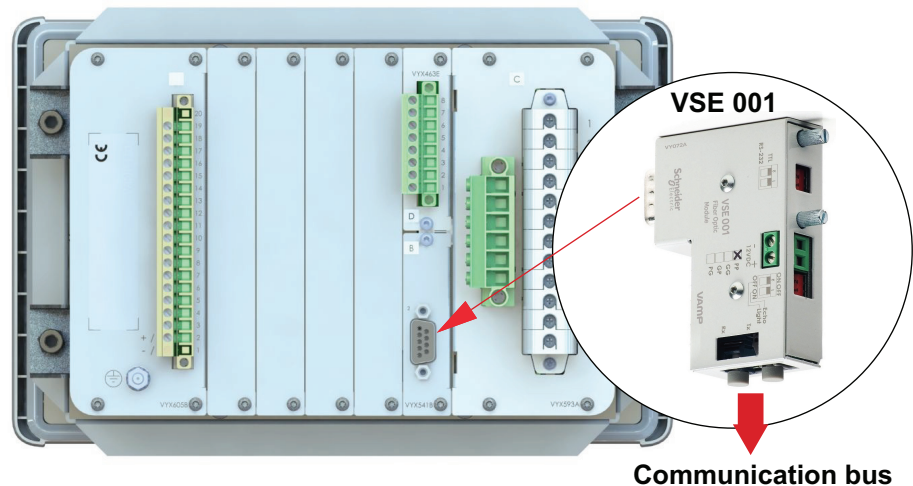

Figure 10.13: VSE-001 module brings serial fiber interface to the device. Module is connected to the RS-232 serial port.

Module interface to the device

The physical interface of the VSE-001 is a 9-pin D-connector. Signal level is RS-232.

NOTE: Product manual for VSE-001 can be found from the company website.

10.7.2 VSE-002 RS-485 interface module

External RS-485 module VSE-002 (VSE002) is used to connect VAMP protection relays to RS-485 bus. With RS-485 serial interface module it is possible to have following serial protocols in use.

- None
- IEC-103
- ModbusSlv
- SpaBus

The power for the module is taken from pin 9 of the D-connector or from an external power supply interface.

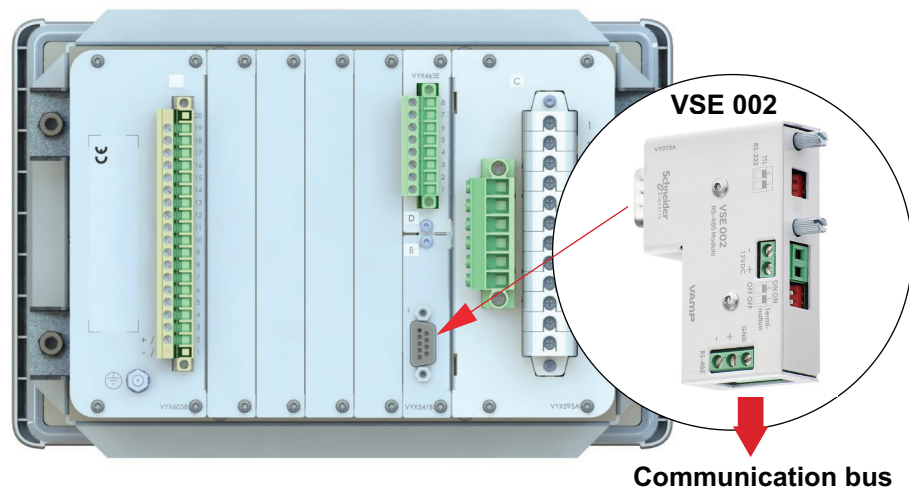

Figure 10.14: VSE-002 module brings serial RS-485 interface to the device. Module is connected to the RS-232 serial port.

Module interface to the device

The physical interface of the VSE-002 is a 9-pin D-connector. Signal level is RS-232 therefore “interface type” of the external module has to be selected as **RS-232**.

It is possible to connect multiple devices in daisychain. When it come to the last of the units in the chain the “termination” has to be selected as **on**. Same applies when only one unit is used.

VSE-002 operates with the relay in RS-232 mode. Therefore “interface type” has to be selected as RS-232.

Pin number	TTL mode	RS-232 mode
1	-	-
2	RXD (in)	RXD (in)
3	TXD (out)	TXD (out)
4	RTS (in)	RTS (in)
5		
6		
7	GND	GND
8		
9	+8V (in)	+8V (in)

	Termination	
	ON 	OFF
Interface type		
TTL 	RS-232 	

10.7.3 VSE-009 DeviceNet interface module

VSE-009 (VSE009) is a DeviceNet interface module for VAMP 300G IED. The IED can be connected to network using DeviceNet as protocol. VSE-009 is attached to the RS-232 D-connector at the back of the IED. With DeviceNet interface module it is possible to have following protocols in use.

- None
- DeviceNet

An external +24VDC power supply interface is required.

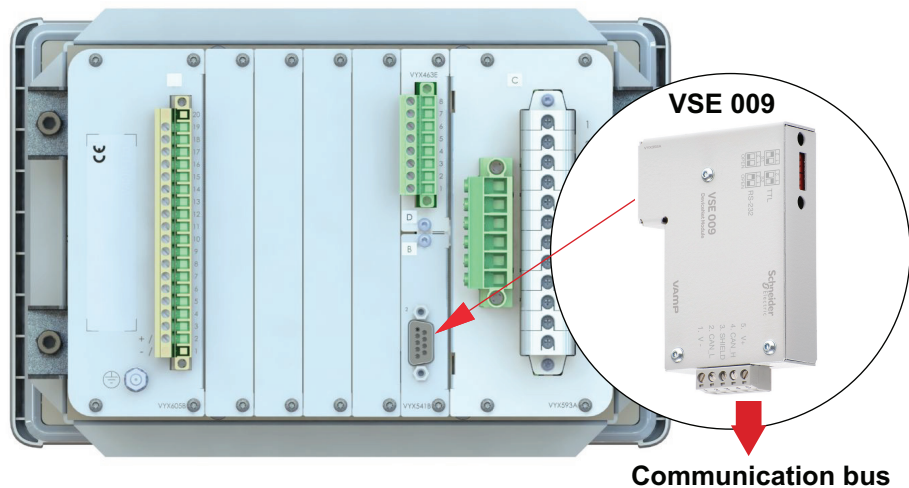

Figure 10.15: VSE-009 module brings DeviceNet interface to the IED. Module is connected to the RS-232 serial port.

10.7.4 VPA-3CG profibus interface module

VAMP 300G can be connected to Profibus DP by using an external profibus interface module VPA-3CG (VPA3CG). The device can then be monitored from the host system. VPA-3CG is attached to the RS-232 D-connector at the back of the IED by using VX-072 (VX072) cable. With profibus interface module it is possible to have following protocols in use.

- None
- ProfibusDP

The power for the module is taken from an external power supply interface.

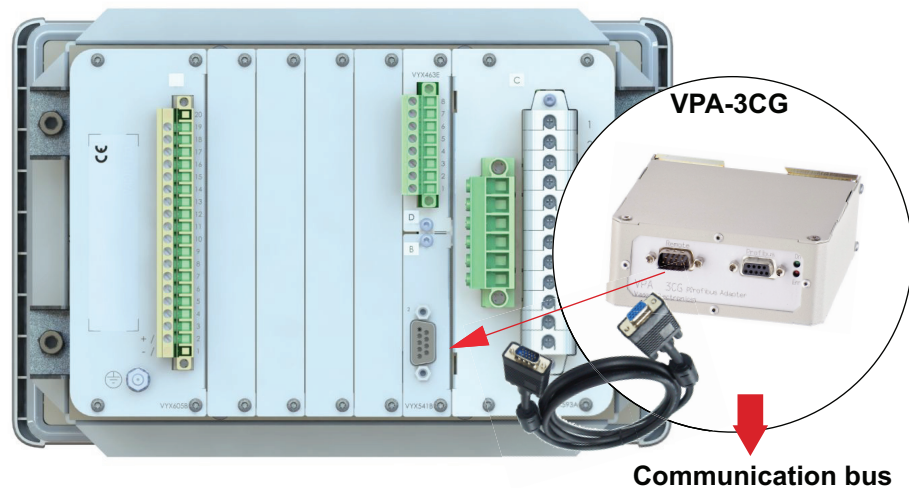

Figure 10.16: VPA-3CG module brings profibus interface to the device. Module is connected to the RS-232 serial port via VX-072 cable.

Module interface to the device

The physical interface of the device is a 9-pin D-connector.

Profibus devices are connected in a bus structure. Up to 32 stations (master or slave) can be connected in one segment. The bus is terminated by an active bus terminator at the beginning and end of each segments. When more than 32 stations are used, repeaters (line amplifiers) must be used to connect the individual bus segments.

The maximum cable length depends on the transmission speed and cable type. The specified cable length can be increased by the use of repeaters. The use of more than 3 repeaters in series is not recommended.

A separate product manual for VPA-3CG can be found from our website.

10.7.5 VIO 12A RTD and analog input / output modules

VIO 12A I/O modules can be connected to VAMP 300G using VSE 001 or VSE 002 interface modules.

A separate product manual for VIO 12A (VVIO12A/EN M/xxxx) can be found from our website.

10.8 Block diagram

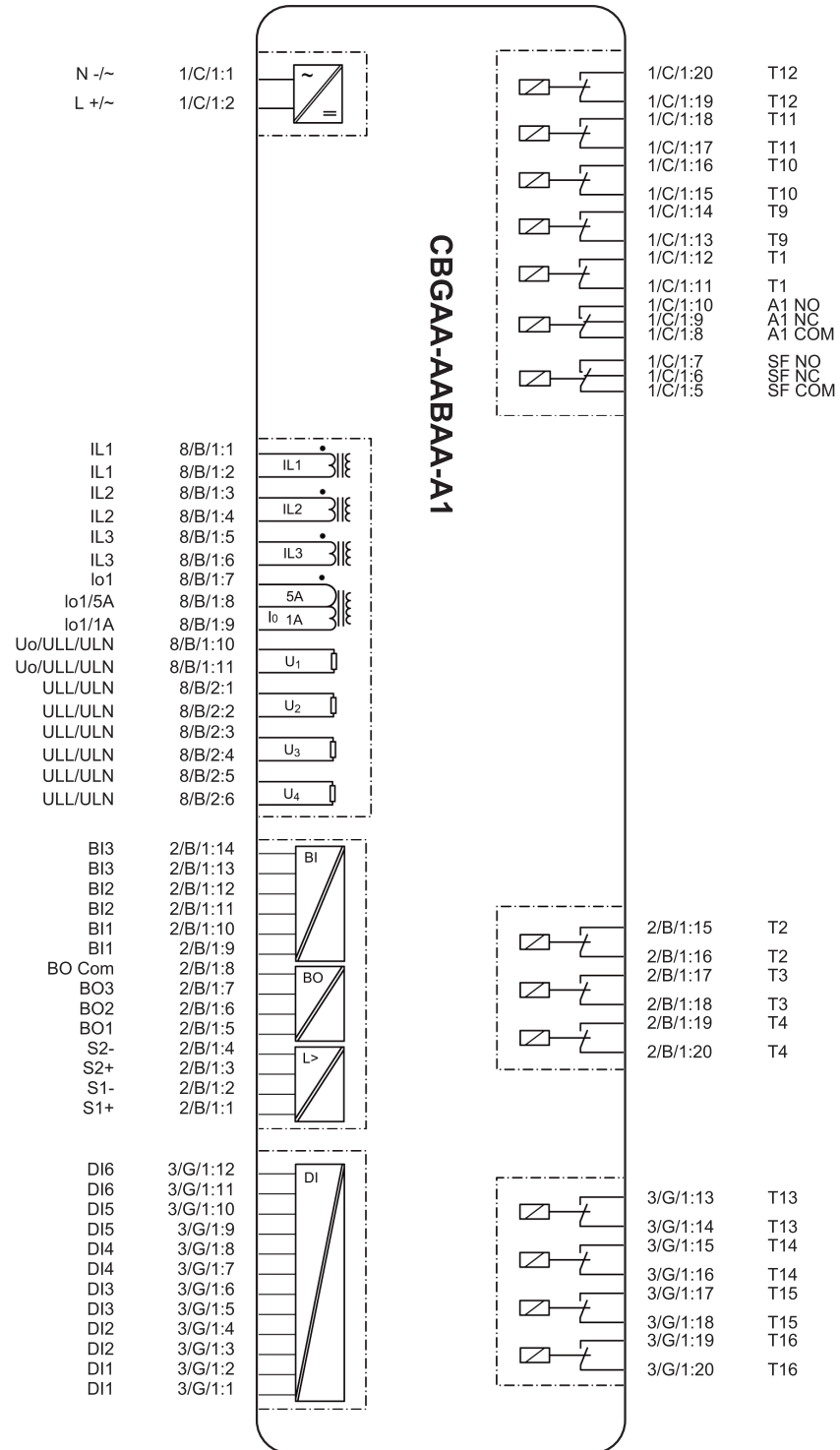

Figure 10.17: V300G-CBGAA-AABAA_A1 block diagram

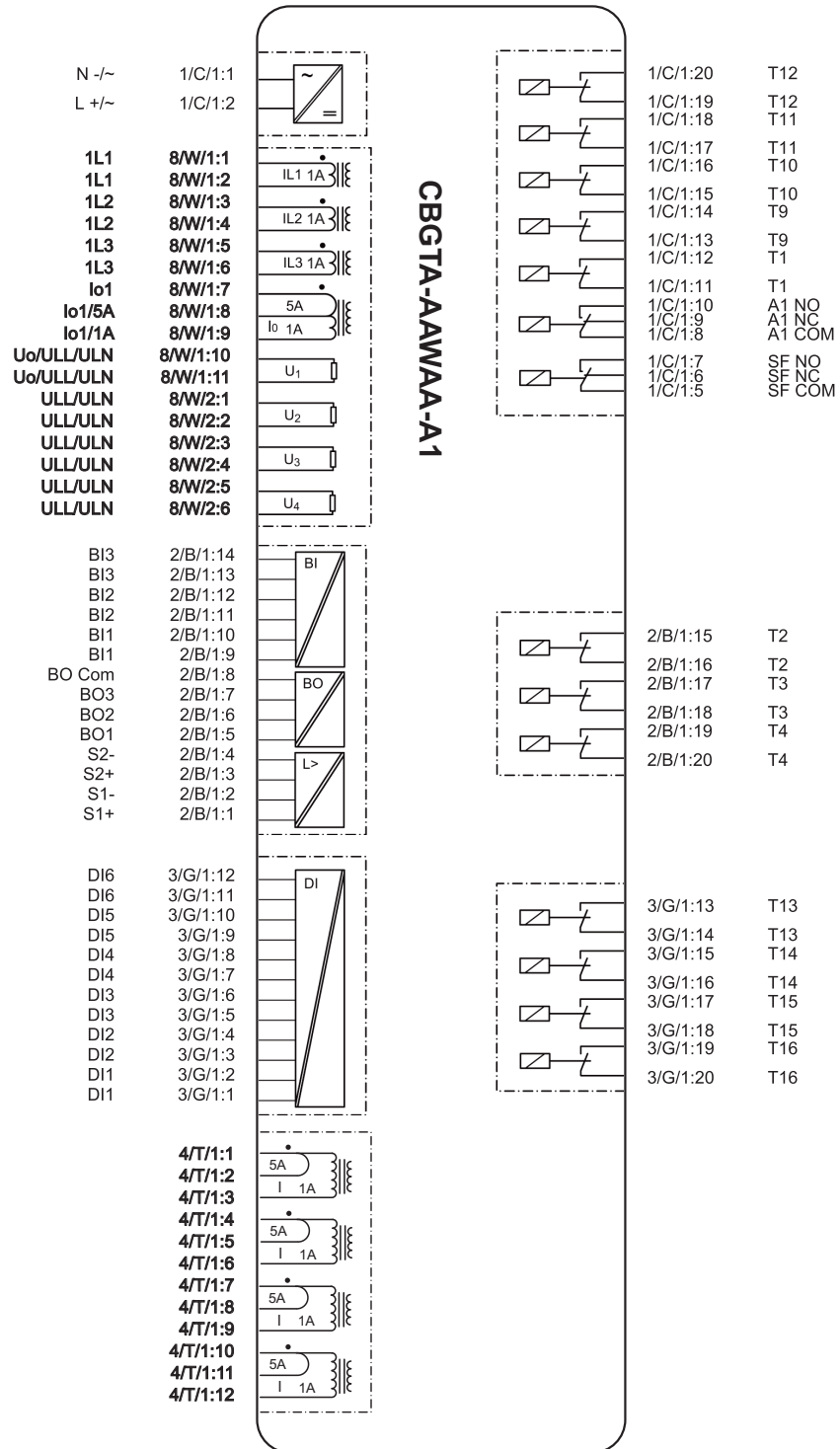

Figure 10.18: V300G-CBGTA-AAWAA_A1 block diagram with differential currents

10.9 Connection examples

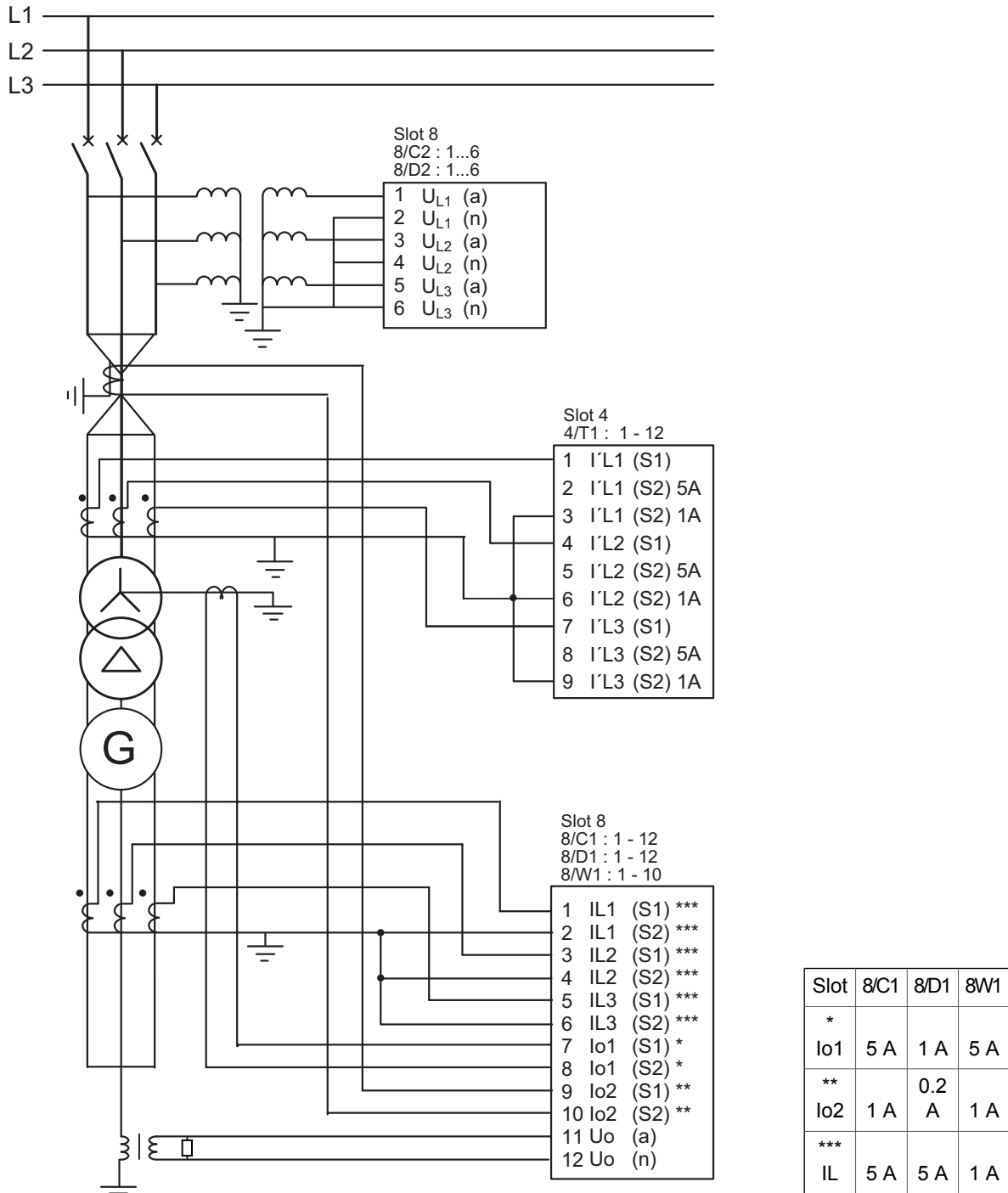

Figure 10.19: Connection example of VAMP 300G with a synchrocheck from phase-to-ground and phase-to-phase voltage using 3xL+4U+2I₀ analogue module. The voltage selection shall be 3LN+LLy in SCALINGS setting view. The zero sequence voltage is internally calculated by the device.

11 Technical data

11.1 Connections

Table 11.1: Measuring circuits T, C, D and W interface

Phase current inputs I' (5/1 A)	Slot 4:		
	$T = 3 \times I (5/1 A) + I_0 (5/1 A)$		
	Rated phase current	5 A	1 A
	- Current measuring range	0.05 – 250 A	0.02 – 50 A
	- Thermal withstand		
	• continuously	20 A	4 A
	• 10 s	100 A	20 A
	• 1 s	500 A	100 A
	- Burden	0.075 VA	0.02 VA
	- Impedance	0.003 Ohm	0.02 Ohm
I₀ input (5A and 1A)			
	- Rated residual current	5 A	1 A
	- Current measuring range	0.05 – 250 A	0.02 – 50 A
	- Thermal withstand		
	• continuously	20 A	4 A
	• 10 s	100 A	20 A
	• 1 s	500 A	100 A
	- Burden	0.075 VA	0.02 VA
	- Impedance	0.003 Ohm	0.02 Ohm
	Phase current inputs I (1A, 5 A)	Slot 8:	
$C = 3L (5 A) + 4U + 2I_0 (5+1 A)$			
$D = 3L (5 A) + 4U + 2I_0 (1+0.2 A)$			
$W = 3L (1 A) + 4U + 2I_0 (1+0.2 A)$			
		C and D	W
Rated phase current		5 A	1A
- Current measuring range		0.05 – 250 A	0.02 – 50 A
- Thermal withstand			
• continuously		20 A	4 A
• 10 s		100 A	20 A
• 1 s	500 A	100 A	
- Burden	0.075 VA	0.02 VA	
- Impedance	0.003 Ohm	0.02 Ohm	

I₀ input (5 A) Rated residual current - Current measuring range - Thermal withstand - Burden - Impedance	Slot 8: $C = 3L (5 A) + 4U + 2I_0 (5+1 A)$ 5 A (configurable for CT secondaries 0.1 – 10 A) 0.015 – 50 A 20 A (continuously) 100 A (for 10 s) 500 A (for 1 s) 0.075 VA 0.003 Ohm
I₀ input (1 A) Rated residual current - Current measuring range - Thermal withstand - Burden - Impedance	Slot 8: $D = 3L (5 A) + 4U + 2I_0 (1+0.2 A)$ $W = 3L (1 A) + 4U + 2I_0 (5+1 A)$ 1 A (configurable for CT secondaries 0.1 – 10.0 A) 0.003 – 10 A 4 A (continuously) 20 A (for 10 s) 100 A (for 1 s) 0.02 VA 0.02 Ohm
I₀ input (0.2 A) Rated residual current - Current measuring range - Thermal withstand - Burden - Impedance	Slot 8: $D = 3L (5 A) + 4U + 2I_0 (1+0.2 A)$ 0.2 A (configurable for CT secondaries 0.1 – 10.0 A) 0.0006 – 2 A 0.8 A (continuously) 4 A (for 10 s) 20 A (for 1 s) 0.02 VA 0.02 Ohm
Voltage inputs Rated voltage U _N - Voltage measuring range - Continuous voltage withstand - Burden	100 V (configurable for VT secondaries 50 – 120 V) 0.5 – 190 V (100 V / 110 V) 250 V < 0.5 VA
Frequency Rated frequency f _N Measuring range	45 – 65 Hz (protection operates accurately) 16 – 95 Hz < 44Hz / > 66Hz (other protection is not steady except frequency protection)

Table 11.2: Auxiliary power supply

U_{AUX}	110 (-20%) – 240 (+10%) V ac/dc 110/120/220/240 V ac 110/125/220 V dc or 24 – 48 \pm 20% V dc 24/48 V dc
Power consumption (order code V300G-CAAAA-AAA) Power consumption increases when more option cards	< 20 W max 40W (with all option card installed)

Table 11.3: Digital inputs internal operating voltage

Number of inputs	As per ordering code
Voltage withstand	265 V ac/dc
Nominal operation voltage for DI inputs	A: 24 – 230 V ac/dc (max. 265 V ac/dc) B: 110 – 230 V ac/dc (max. 265 V ac/dc) C: 220 – 230 V ac/dc (max. 265 V ac/dc)
Typical switching threshold	A: 12 V dc B: 75 V dc C: 155 V dc
Current drain	< 4 mA (typical approx. 3mA)
Activation time dc/ac	< 11 ms / < 15 ms
Reset time dc/ac	< 11 ms / < 15 ms
Terminal block: - MSTB2.5 – 5.08	Maximum wire dimension: 2.5 mm ² (13 – 14 AWG)

NOTE: set dc/ac mode according to the used voltage in VAMPSET.

Table 11.4: Trip contact, high break

Number of contacts	5 normal open contacts
Rated voltage	250 V ac/dc
Continuous carry	5 A
Minimum making current	100 mA @ 24 Vdc
Make and carry, 0.5s at duty cycle 10%	30 A
Make and carry, 3s at duty cycle 10%	15 A
Breaking capacity, AC	2 000 VA
Breaking capacity, DC (L/R=40ms)	
at 48 V dc:	5 A
at 110 V dc:	3 A
at 220 V dc	1 A
Contact material	AgNi 90/10
Terminal block:	Maximum wire dimension:
- Phoenix MVSTBW or equivalent	2.5 mm ² (13-14 AWG)

NOTE: High break trip contacts exist in power module C and D only.

Table 11.5: Trip contact, Tx

Number of contacts	As per ordering code
Rated voltage	250 V ac/dc
Continuous carry	5 A
Minimum making current	100 mA at 24 Vdc
Typical operate time (applies only to arc output matrix controlled outputs)	≤8 ms
Make and carry, 0.5 s	30 A
Make and carry, 3 s	15 A
Breaking capacity, ac	2 000 VA
Breaking capacity, dc (L/R = 40ms)	
at 48 V dc:	1.15 A
at 110 V dc:	0.5 A
at 220 V dc:	0.25 A
Contact material	AgNi 90/10
Terminal block:	Wire dimension:
- MSTB2.5 - 5.08	Maximum 2.5 mm ² (13 – 14 AWG)
	Minimum 1.5 mm ² (15 – 16 AWG)

Table 11.6: Signal contact, A1

Number of contacts:	1
Rated voltage	250 V ac/dc
Continuous carry	5 A
Minimum making current	100 mA at 24 V ac/dc
Breaking capacity, dc (L/R = 40ms)	
at 48 V dc:	1 A
at 110 V dc:	0.3 A
at 220 V dc:	0.15 A
Contact material	AgNi 0.15 gold plated
Terminal block	Wire dimension
- MSTB2.5 - 5.08	Maximum 2.5 mm ² (13 – 14 AWG)
	Minimum 1.5 mm ² (15 – 16 AWG)

Table 11.7: Local serial communication port

Number of ports	1 on front
Electrical connection	USB
Data transfer rate	1 200 – 187 500 b/s
Protocols	GetSet

Table 11.8: COM 3-4 serial communication port

Number of physical ports	0 - 1 on rear panel (option)
Electrical connection	RS-232 (option, IRIG-B included) RS-485 (option) Profibus (option, external module) Glass fibre connection (option, external module)
Protocols	Modbus, RTU master Modbus, RTU slave Spabus, slave IEC 60870-5-103 IEC 61870-5-101 Profibus DP DNP 3.0 GetSet IRIG-B

Table 11.9: Ethernet communication port

Number of ports	0 – 2 on rear panel (option)
Electrical connection	RJ-45 100Mbps (option) LC 100Mbps (option)
Protocols	IEC 61850 Modbus TCP DNP 3.0 Ethernet IP IEC 61870-5-101

Table 11.10: Ethernet fiber interface

Type	Multimode
Connector	LC
Physical layer	100 Base-Fx
Maximum cable distance	2 km
Optical wave length	1300 nm
Cable core / cladding size	50/125 or 62.5/125 μm

11.2 Test and environmental conditions

Table 11.11: Disturbance tests

Test	Standard & Test class / level	Test value
Emission	EN 61000-6-4 / IEC 60255-26	
- Conducted	EN 55011, Class A / IEC 60255-25	0.15 – 30 MHz
- Emitted	EN 55011, Class A / IEC 60255-25 / CISPR 11	30 – 1000 MHz
Immunity	EN 61000-6-2 / IEC 60255-26	
- 1 Mhz damped oscillatory wave	IEC 60255-22-1	±2.5kVp CM, ±2.5kVp DM
- Static discharge (ESD)	EN 61000-4-2 Level 4 / IEC 60255-22-2 Class 4	±8 kV contact, ±15 kV air
- Emitted HF field	EN 61000-4-3 Level 3 / IEC 60255-22-3	80 - 2700 MHz, 10 V/m
- Fast transients (EFT)	EN 61000-4-4 Level 4 / IEC 60255-22-4 Class A	±4 kV, 5/50 ns, 5 kHz
- Surge	EN 61000-4-5 Level 4 / IEC 60255-22-5	±4 kV, 1.2/50 µs, CM ±2 kV, 1.2/50 µs, DM
- Conducted HF field	EN 61000-4-6 Level 3 / IEC 60255-22-6	0.15 - 80 MHz, 10 Vrms
- Power-frequency magnetic field	EN 61000-4-8	300A/m (continuous), 1000A/m 1-3s
- Pulse magnetic field	EN 61000-4-9 Level 5	1000A/m, 1.2/50 µs
- Voltage dips	EN 61000-4-29 / IEC 60255-11	30%/1s, 60%/0.1s, 100%/0.01s
- Voltage short interruptions	EN 61000-4-11	30%/10ms, 100%/10ms, 60%/100ms, >95%/5000ms
- Voltage alternative component	EN 61000-4-17 / IEC 60255-11	12% of operating voltage (DC) / 10min

Table 11.12: Electrical safety tests

Test	Standard & Test class / level	Test value
- Impulse voltage withstand	EN 60255-5, Class III	5 kV, 1.2/50 µs, 0.5 J 1 kV, 1.2/50 µs, 0.5 J Communication
- Dielectric test	EN 60255-5, Class III	2 kV, 50 Hz 0.5 kV, 50 Hz Communication
- Insulation resistance	EN 60255-5	>100Mohm, 500V / 100V
- Protective bonding resistance	EN 60255-27	< 0.1 ohm
- Power supply burden	IEC 60255-1	> 20W internal

Table 11.13: Mechanical tests

Test	Standard & Test class / level	Test value
Device in operation		
- Vibrations	IEC 60255-21-1, Class II / IEC 60068-2-6, Fc	1Gn, 10Hz – 150 HZ
- Shocks	IEC 60255-21-2, Class II / IEC 60068-2-27, Ea	10Gn/11ms
Device de-energized		
- Vibrations	IEC 60255-21-1, Class II / IEC 60068-2-6, Fc	2Gn, 10Hz – 150 HZ
- Shocks	IEC 60255-21-2, Class II / IEC 60068-2-27, Ea	30Gn/11ms
- Bump	IEC 60255-21-2, Class II / IEC 60068-2-27, Ea	20Gn/16ms

Table 11.14: Environmental tests

Test	Standard & Test class / level	Test value
Device in operation		
- Dry heat	EN / IEC 60068-2-2, Bd	70°C (158°F)
- Cold	EN / IEC 60068-2-1, Ad	-40°C (-40°F)
- Damp heat, cyclic	EN / IEC 60068-2-30, Db	<ul style="list-style-type: none"> • From 25°C (77°F) to 55°C (131°F) • From 93% RH to 98% RH • Testing duration: 6 days
- Damp heat, static	EN / IEC 60068-2-78, Cab	<ul style="list-style-type: none"> • 40°C (104°F) • 93% RH • Testing duration: 10 days
Device in storage		
- Dry heat	EN / IEC 60068-2-2, Bb	70°C (158°F)
- Cold	EN / IEC 60068-2-1, Ab	-40°C (-40°F)

Table 11.15: Environmental conditions

Ambient temperature, in-service	-40 – 60°C (-40 – 140°F)*
Ambient temperature, storage	-40 – 70°C (-40 – 158°F)
Relative air humidity	< 95%, no condensation allowed
Maximum operating altitude	2000 m (6561.68 ft)

* Recommended values with VYX 695 projection mounting frame:

- VAMP 300 with 1 x raising frame -> maximum ambient temperature 55°C
- VAMP 300 with 2 x raising frame -> maximum ambient temperature 50°C

Table 11.16: Casing

Degree of protection (IEC 60529)	IP54 Front panel, IP20 rear side
Dimensions (W x H x D)	270 x 176 x 230 mm / 10.63 x 6.93 x 9.06 in
Weight	4.2 kg (9.272 lb) or higher (depends of options)

11.3 Protection functions

For setting values, the step size is mentioned if it differs from the given resolution.

*) EI = Extremely Inverse, NI = Normal Inverse, VI = Very Inverse, LTI = Long Time Inverse, MI = Moderately Inverse

***) This is the instantaneous time i.e. the minimum total operational time including the fault detection time and operation time of the trip contacts.

11.3.1 Differential protection

Table 11.17: Differential overcurrent stage $\Delta I >$ (87)

Pick up value	5 – 50 % I_N
Bias current for start of slope 1	0.50 x I_N
Slope 1	5 – 100 %
Bias current for start of slope 2	1.00 – 3.00 x I_N
Slope 2	100 – 200 %
Second harmonic blocking	5 – 30 %, or disable
Fifth harmonic blocking	20 – 50 %, or disable
Reset time	< 95 ms
Reset ratio	0.95
Inaccuracy:	
- 2nd harmonic blocking	±2% - unit
- 5th harmonic blocking	±3% - unit
- Starting	±3% of set value or 0.02 x I_N when currents are < 200 mA
- Operating time ($I_D > 1.2 \times I_{SET}$)	< 60 ms
- Operating time ($I_D > 3.5 \times I_{SET}$)	< 50 ms

NOTE: The amplitude of second harmonic content has to be at least 2% of the nominal of CT. If the nominal current is 5 A, the 100 Hz component needs to exceed 100 mA.

Table 11.18: Differential overcurrent stage $\Delta I >>$ (87)

Pick-up value	5.0 – 40.0 x I_N
Reset time	< 95 ms
Reset ratio	0.95
Inaccuracy:	
- Starting	±3% of set value or ±0.5% of rated value
- Operating time ($I_D > 3.5 \times I_{SET}$)	< 40 ms

11.3.2 Non-directional current protection

Table 11.19: Overcurrent stage I> (50/51)

Input signal	$I_{L1} - I_{L3}$
Pick-up value	$0.05 - 5.00 \times I_{MODE}$ (step 0.01)
Definite time function:	DT**
- Operate time	0.04 – 300.00 s (step 0.01 s)
IDMT function:	
- Delay curve family	(DT), IEC, IEEE, RI Prg
- Curve type	EI, VI, NI, LTI, MI..., depends on the family*
- Time multiplier k	0.05 – 20.0, except 0.50 – 20.0 for RXIDG, IEEE and IEEE2
Start time	Typically 30 ms
Reset time	<95 ms
Retardation time	< 50 ms
Reset ratio	0.97
Transient over-reach, any τ	< 10 %
Inaccuracy:	
- Starting	$\pm 3\%$ of the set value or 5 mA secondary
- Operate time at definite time function	$\pm 1\%$ or ± 25 ms
- Operate time at IDMT function	$\pm 5\%$ or at least ± 25 ms**

Table 11.20: Overcurrent stage I>> (50/51)

Input signal	$I_{L1} - I_{L3}$
Pick-up value	$0.10 - 20.00 \times I_{MODE}$ (step 0.01)
Definite time function:	DT**
Operate time	0.04 – 1800.00 s (step 0.01 s)
Start time	Typically 30 ms
Reset time	<95 ms
Retardation time	< 50 ms
Reset ratio	0.97
Transient over-reach, any τ	< 10 %
Inaccuracy:	
- Starting	$\pm 3\%$ of the set value or 5 mA secondary
- Operate time	$\pm 1\%$ or ± 25 ms

Table 11.21: Overcurrent stages I>>> (50/51)

Input signal	$I_{L1} - I_{L3}$
Pick-up value	0.10 – 40.00 x I_{MODE} (step 0.01)
Definite time function:	DT**
Operate time	0.03 – 300.00 s (step 0.01 s)
Instant operate time:	
I_M / I_{SET} ratio > 1.5	<30 ms
I_M / I_{SET} ratio 1.03 – 1.5	< 50 ms
Start time	Typically 20 ms
Reset time	<95 ms
Retardation time	< 50 ms
Reset ratio	0.97
Inaccuracy:	
- Starting	±3% of the set value or 5 mA secondary
- Operate time DT (I_M/I_{SET} ratio > 1.5)	±1% or ±15 ms
- Operate time DT (I_M/I_{SET} ratio 1.03 – 1.5)	±1% or ±25 ms

Table 11.22: Thermal overload stage T> (49)

Input signal	$I_{L1} - I_{L3}$
Maximum continuous current:	0.1 – 2.40 x I_{MODE} (step 0.01)
Alarm setting range:	60 – 99 % (step 1%)
Time constant Tau:	2 – 180 min (step 1)
Cooling time coefficient:	1.0 – 10.0 x Tau (step 0.1)
Max. overload at +40°C	70 – 120 % I_{MODE} (step 1)
Max. overload at +70°C	50 – 100 % I_{MODE} (step 1)
Ambient temperature	-55 – 125°C (step 1°)
Resetting ratio (Start & trip)	0.95
Accuracy:	
- Operate time	±5% or ±1 s

Table 11.23: Unbalance stage $I_2>$, $I'_2>$ (46)

Input signal	$I_{L1} - I_{L3}$
Pick-up value	2 – 70% (step 1%)
Definite time characteristic: - Operate time	1.0 – 600.0 s (step 0.1 s)
Inverse time characteristic: - 1 characteristic curve - time multiplier - upper limit for inverse time	Inv 1 – 50 s (step 1) 1000 s
Start time	Typically 300 ms
Reset time	< 450 ms
Reset ratio	0.95
Inaccuracy: - Starting - Operate time	$\pm 1\%$ - unit $\pm 5\%$ or ± 200 ms

NOTE: Stage is operational when all secondary currents are above 250 mA.

Table 11.24: Voltage restrained/controlled overcurrent stage $I_V>$ (51V)

Settings: - $I_V>$ - U_{X1} , U_{X2} - I_{Y1} , I_{Y2}	$0.50 - 4.00 \times I_{GN}$ 0 – 150 % 0 – 200 % $I_V>$
Definite time function: - Operate time	0.08** – 300.00 s (step 0.02 s)
Start time	Typically 60 ms
Reset time	<95 ms
Retardation time	< 50 ms
Reset ratio	0.97
Transient over-reach, any τ	< 10 %
Inaccuracy: - Starting - Operate time at definite time function	$\pm 3\%$ of set value $\pm 1\%$ or ± 30 ms

Table 11.25: Earth fault stage $I_0 >$ (50N/51N)

Input signal	I_{01}, I_{02} $I_{0Calc} (= I_{L1} + I_{L2} + I_{L3})$
Pick-up value	0.005 – 8.00 pu (when I_{01} or I_{02}) (step 0.001) 0.05 – 20.0 pu (when I_{0Calc})
Definite time function:	DT**
- Operate time	0.04** – 300.00 s (step 0.01 s)
IDMT function:	
- Delay curve family	(DT), IEC, IEEE, RI Prg
- Curve type	EI, VI, NI, LTI, MI..., depends on the family*
- Time multiplier k	0.05 – 20.0, except 0.50 – 20.0 for RXIDG, IEEE and IEEE2
Start time	Typically 30 ms
Reset time	<95 ms
Reset ratio	0.95
Inaccuracy:	
- Starting	$\pm 2\%$ of the set value or $\pm 0.3\%$ of the rated value
- Starting (Peak mode)	$\pm 5\%$ of the set value or $\pm 2\%$ of the rated value (Sine wave <65 Hz)
- Operate time at definite time function	$\pm 1\%$ or ± 25 ms
- Operate time at IDMT function	$\pm 5\%$ or at least ± 25 ms**

Table 11.26: Earth fault stages $I_0 >>$, $I_0 >>>$, $I_0 >>>>$ (50N/51N)

Input signal	I_{01}, I_{02} $I_{0Calc} (= I_{L1} + I_{L2} + I_{L3})$
Pick-up value	0.01 – 8.00 pu (When I_{01} or I_{02}) (step 0.01) 0.05 – 20.0 pu (When I_{0Calc}) (step 0.01)
Definite time function:	
- Operate time	0.04** – 300.00 s (step 0.01 s)
Start time	Typically 30 ms
Reset time	<95 ms
Reset ratio	0.95
Inaccuracy:	
- Starting	$\pm 2\%$ of the set value or $\pm 0.3\%$ of the rated value
- Starting (Peak mode)	$\pm 5\%$ of the set value or $\pm 2\%$ of the rated value (Sine wave <65 Hz)
- Operate time	$\pm 1\%$ or ± 25 ms

11.3.3 Directional current protection

Table 11.27: Directional overcurrent stages $I_{\phi}>$, $I_{\phi}>>$ (67)

Input signal	$I_{L1} - I_{L3}$ $U_{L1} - U_{L3}$
Pick-up value	0.10 – 4.00 x I_{MODE} (step 0.01)
Mode	Directional/Directional+BackUp
Minimum voltage for the direction solving	2 $V_{SECONDARY}$
Base angle setting range	-180° – +179°
Operation angle	±88°
Definite time function:	DT**
- Operate time	0.04 – 300.00 s (step 0.01)
IDMT function:	
- Delay curve family	(DT), IEC, IEEE, RI Prg
- Curve type	EI, VI, NI, LT1, MI... depends on the family*
- Time multiplier k	0.05 – 20.0, except 0.50 – 20.0 for RXIDG, IEEE and IEEE2
Start time	Typically 30 ms
Reset time	<95 ms
Retardation time	< 50 ms
Reset ratio	0.95
Reset ratio (angle)	2°
Transient over-reach, any τ	< 10 %
Adjustable voltage memory length	0.2 – 3.2 s
Inaccuracy:	
- Starting (rated value $I_N = 1-5A$)	±3% of the set value or ±0.5% of the rated value
- Angle	±2° $U > 5 V$ ±30° $U = 0.1 - 5.0 V$
- Operate time at definite time function	±1% or ±25 ms
- Operate time at IDMT function	±5% or at least ±30 ms**

Table 11.28: Directional overcurrent stages $I_{\phi}>>>$, $I_{\phi}>>>>$ (67)

Input signal	$I_{L1} - I_{L3}$ $U_{L1} - U_{L3}$
Pick-up value	0.10 – 20.00 x I_{MODE} (step 0.01)
Mode	Directional/Directional+BackUp
Minimum voltage for the direction solving	2 $V_{SECONDARY}$
Base angle setting range	-180° – +179°
Operation angle	±88°
Definite time function:	DT**
- Operate time	0.04 – 300.00 s (step 0.01)
Start time	Typically 30 ms
Reset time	<95 ms
Retardation time	< 50 ms
Reset ratio	0.95
Reset ratio (angle)	2°
Transient over-reach, any τ	< 10 %
Adjustable voltage memory length	0.2 – 3.2 s
Inaccuracy:	
- Starting (rated value $I_N = 1 - 5A$)	±3% of the set value or ±0.5% of the rated value
- Angle	±2° $U > 5 V$ ±30° $U = 0.1 - 5.0 V$
- Operate time at definite time function	±1% or ±25 ms

Table 11.29: Directional earth fault stages $I_{0\phi}>$, $I_{0\phi}>>$ (67N)

Input signal	I_0 , U_0 I_{0Calc} ($= I_{L1} + I_{L2} + I_{L3}$)
Pick-up value	0.005 – 20.00 x I_{0N} (up to 8.00 for inputs other than I_{0Calc})
Start voltage	1 – 50 % U_{0N} (step 1%)
Mode	Non-directional/Sector/ResCap
Base angle setting range	-180° – 179°
Operation angle	±88°
Definite time function:	
- Operate time	0.10** – 300.00 s (step 0.02 s)
IDMT function:	
- Delay curve family	(DT), IEC, IEEE, RI Prg
- Curve type	EI, VI, NI, LTI, MI..., depends on the family*
- Time multiplier k	0.05 – 20.0, except 0.50 – 20.0 for RI, IEEE and IEEE2
Start time	Typically 60 ms
Reset time	<95 ms
Reset ratio	0.95
Reset ratio (angle)	2°
Inaccuracy:	
- Starting U_0 & I_0 (rated value $I_n = 1 – 5A$)	±3% of the set value or ±0.3% of the rated value
- Starting U_0 & I_0 (Peak Mode when, rated value $I_{0n} = 1 – 10A$)	±5% of the set value or ±2% of the rated value (Sine wave <65 Hz)
- Starting U_0 & I_0 (I_{0Calc})	±3% of the set value or ±0.5% of the rated value
- Angle	±2° when $U > 1V$ and $I_0 > 5\%$ of I_{0N} or $> 50 mA$ else ±20°
- Operate time at definite time function	±1% or ±30 ms
- Operate time at IDMT function	±5% or at least ±30 ms**

11.3.4

Switch On To Fault stage SOTF (50HS)

Table 11.30: Switch On To Fault stage SOTF (50HS)

Pick-up value	1.00 – 3.00 x I_N (step 0.01)
Dead line detection delay	0.00 – 60.00 s (step 0.01)
SOTF active after CB closure	0.10 – 60.00 s (step 0.01)
Operating time	< 30 ms (When I_M/I_{SET} ratio > 1.5)
Reset time	< 95 ms
Reset ratio	0.97
Inaccuracy	±3% of the set value or 5 mA secondary

11.3.5 Voltage protection

Table 11.31: Overvoltage stage U> (59)

Input signal	$U_{L1} - U_{L3}$
Pick-up value	50 – 150 % U_N (step 1%)
Definite time characteristic:	
- Operate time	0.08** – 300.00 s (step 0.02)
Hysteresis	0.99 – 0.800 (0.1 – 20.0 %, step 0.1 %)
Start time	Typically 60 ms
Release delay	0.06 – 300.00 s (step 0.02)
Reset time	<95 ms
Retardation time	< 50 ms
Inaccuracy:	
- Starting	±3% of the set value
- Operate time	±1% or ±30 ms

Table 11.32: Overvoltage stage U>> (59)

Input signal	$U_{L1} - U_{L3}$
Pick-up value	50 – 150 % U_N (step 1%)
Definite time characteristic:	
- Operate time	0.06** – 300.00 s (step 0.02)
Hysteresis	0.99 – 0.800 (0.1 – 20.0 %, step 0.1 %)
Start time	Typically 60 ms
Reset time	<95 ms
Retardation time	< 50 ms
Inaccuracy:	
- Starting	±3% of the set value
- Operate time	±1% or ±30 ms

Table 11.33: Overvoltage stage U>>> (59)

Input signal	$U_{L1} - U_{L3}$
Pick-up value	50 – 160 % U_N (step 1%)
Definite time characteristic:	
- Operate time	0.04** – 300.00 s (step 0.01)
Hysteresis	0.99 – 0.800 (0.1 – 20.0 %, step 0.1 %)
Start time	Typically 30 ms
Reset time	<95 ms
Retardation time	< 50 ms
Inaccuracy:	
- Starting	±3% of the set value
- Operate time	±1% or ±25 ms

Table 11.34: Volts/hertz over-excitation protection $U_{\dot{p}}$, $U_{\dot{p}}>$ (24)

Pick-up setting range	100 – 200 %
Operating time	0.3 – 300.0 s
Start time	Typically 200 ms
Reset time	< 450 ms
Reset ratio	0.995
Inaccuracy:	
- Starting	U < 0.5 % unit f < 0.05 Hz
- Operating time at definite time function	±1 % or ±150 ms

Table 11.35: Positive sequence undervoltage stages $U_{1<}$, $U_{1<<}$ (27P)

Pick-up value	20 – 120% x U_N
Definite time function:	
- Operating time	0.08** – 300.00 s
Undervoltage blocking	2 – 100% x U_N (common for both stages)
- Blocking time, when $I < 1\% \times I_{GN}$	2 – 100% x U_{GN} (common for both stages) 0 – 30 s (common for both stages)
Start time	Typically 60 ms
Reset time	<95 ms
Retardation time	< 50 ms
Reset ratio	1.05
Inaccuracy:	
- Starting	1% unit
- Operating time	±1% or ±30 ms

NOTE: To make the relay trip after low voltage blocking, the positive sequence voltage has to go above the pick-up setting.

Table 11.36: Undervoltage stage $U<$ (27)

Input signal	$U_{L1} - U_{L3}$
Pick-up value	20 – 120 % U_N (step 1%)
Definite time characteristic:	
- Operate time	0.08** – 300.00 s (step 0.02)
Hysteresis	1.001 – 1.200 (0.1 – 20.0 %, step 0.1 %)
Self-blocking value of the undervoltage	0 – 80 % U_N
Start time	Typically 60 ms
Release delay	0.06 – 300.00 s (step 0.02 s)
Reset time	<95 ms
Retardation time	< 50 ms
Reset ratio (Block limit)	0.5 V or 1.03 (3 %)
Reset ratio	1.03 (depends on the hysteresis setting)
Inaccuracy:	
- Starting	±3% of the set value
- Blocking	±3% of set value or ±0.5 V
- Operate time	±1% or ±30 ms

Table 11.37: Undervoltage stage $U<<$ (27)

Input signal	$U_{L1} - U_{L3}$
Pick-up value	20 – 120 % U_N (step 1%)
Definite time characteristic:	
- Operate time	0.06** – 300.00 s (step 0.02)
Hysteresis	1.001 – 1.200 (0.1 – 20.0 %, step 0.1 %)
Self-blocking value of the undervoltage	0 – 80 % U_N
Start time	Typically 60 ms
Reset time	<95 ms
Retardation time	< 50 ms
Reset ratio (Block limit)	0.5 V or 1.03 (3 %)
Reset ratio	1.03 (depends on the hysteresis setting)
Inaccuracy:	
- Starting	±3% of the set value
- Blocking	±3% of set value or ±0.5 V
- Operate time	±1% or ±30 ms

Table 11.38: Undervoltage stage $U \lll (27)$

Input signal	$U_{L1} - U_{L3}$
Pick-up value	20 – 120 % U_N (step 1%)
Definite time characteristic:	
- Operate time	0.04** – 300.00 s (step 0.01)
Hysteresis	1.001 – 1.200 (0.1 – 20.0 %, step 0.1 %)
Self-blocking value of the undervoltage	0 - 80 % U_N
Start time	Typically 30 ms
Reset time	<95 ms
Retardation time	< 50 ms
Reset ratio (Block limit)	0.5 V or 1.03 (3 %)
Reset ratio	1.03 (depends on the hysteresis setting)
Inaccuracy:	
- Starting	±3% of the set value
- Blocking	±3% of set value or ±0.5 V
- Operate time	±1% or ±25 ms

Table 11.39: Zero sequence voltage stage $U_0 > (59N)$

Input signal	U_0 $U_{0Calc} (= U_{L1} + U_{L2} + U_{L3})$
Pick-up value	1 – 60 % U_{0N} (step 1%)
Definite time function:	
- Operate time	0.3 – 300.0 s (step 0.1 s)
Start time	Typically 200 ms
Reset time	< 450 ms
Reset ratio	0.97
Inaccuracy:	
- Starting	±2% of the set value or ±0.3% of the rated value
- Starting U_{0Calc} (3LN mode)	±1 V
- Operate time	±1 % or ±150 ms

Table 11.40: Zero sequence voltage stage $U_0 >>$ (59N)

Input signal	U_0 $U_{0Calc} (= U_{L1} + U_{L2} + U_{L3})$
Pick-up value	1 – 60 % U_{0N} (step 1%)
Definite time function:	
- Operate time	0.08 – 300.0 s (step 0.02 s)
Start time	Typically 60 ms
Reset time	<95 ms
Reset ratio	0.97
Inaccuracy:	
- Starting	$\pm 2\%$ of the set value or $\pm 0.3\%$ of the rated value
- Starting U_{0Calc} (3LN mode)	± 1 V
- Operate time	$\pm 1\%$ or ± 30 ms

Table 11.41: 100% stator earth fault protection $U_{0f3} <$ (64F3)

Pick-up value	1 – 50 %
Definite time function:	
- Operating time	0.5 – 30.0 minutes
Start time	<2 s
Reset time	<4 s
Reset ratio	1.05 (When pick-up setting is below 5%, reset value is less than set value +0.5 % unit)
Fundamental low voltage block limit (U12 and U23)	Blocked when U_{12} and $U_{23} < 65\%$ of nominal
Inaccuracy:	
- Starting	$\pm 1\%$ units
- Operating time at definite time function	$\pm 1\%$ or ± 2 s

NOTE: The voltage measurement mode must be "2LL + U_0 or 3LN + U_0 " when this protection stage is used.

11.3.6

Circuit-breaker failure protection CBFP (50BF)

Table 11.42: Circuit-breaker failure protection CBFP (50BF)

Relay to be supervised	T1 – T4 (depending the ordering code)
Definite time function:	
- Operate time	0.1** – 10.0 s (step 0.1 s)
Inaccuracy	
- Operate time	± 20 ms

11.3.7 Magnetising inrush 68F2

Table 11.43: Magnetising inrush 68F2

Input signal	$I_{L1} - I_{L3}$
Settings:	
- Pick-up value	10 – 100 % (step 1%)
- Operate time	0.03 – 300.00 s (step 0.01 s)
Inaccuracy:	
- Starting	±1% - unit

NOTE: The amplitude of second harmonic content has to be at least 2% of the nominal of CT. If the nominal current is 5 A, the 100 Hz component needs to exceed 100 mA.

11.3.8 Over excitation 68F5

Table 11.44: Over excitation 68F5

Input signal	$I_{L1} - I_{L3}$
Settings:	
- Setting range over excitation	10 – 100 % (step 1%)
- Operate time	0.03 – 300.00 s (step 0.01 s)
Inaccuracy:	
- Starting	±2%- unit

NOTE: The amplitude of fifth harmonic content has to be at least 2% of the nominal of CT. If the nominal current is 5 A, the 250 Hz component needs to exceed 100 mA.

11.3.9 Frequency protection

Table 11.45: Overfrequency and underfrequency stages $f > <$, $f >> <<$ (81H/81L)

Input signal	$U_{L1} - U_{L3}$
Frequency measuring area	16.0 – 75.0 Hz
Current and voltage meas. range	45.0 – 65.0 Hz
Frequency stage setting range	40.0 – 70.0 Hz (step 0.01)
Low voltage blocking	10 – 100 % U_N
Definite time function:	
- Operate time	0.10** – 300.0 s (step 0.02 s)
Start time	< 100 ms
Reset time	<120 ms
Reset ratio (LV block)	Instant (no hysteresis)
Inaccuracy:	
- Starting	± 20 mHz
- Starting (LV block)	3% of the set value or ± 0.5 V
- Operate time	$\pm 1\%$ or ± 30 ms

NOTE: If device restarts for some reason there will be no trip even if the frequency is below the set limit during the start up (Start and trip is blocked). To cancel this block, frequency has to rise above the set limit.

Table 11.46: Underfrequency stages $f <$, $f <<$ (81L)

Input signal	$U_{L1} - U_{L3}$
Frequency measuring area	16.0 – 75.0 Hz
Current and voltage meas. range	45.0 – 65.0 Hz
Frequency stage setting range	40.0 – 64.0 Hz
Low voltage blocking	10 – 100 % U_N
Definite time function:	
- Operate time	0.10** – 300.0 s (step 0.02 s)
Undervoltage blocking	2 – 100 %
Start time	< 100 ms
Reset time	<120 ms
Reset ratio	1.002
Reset ratio (LV block)	Instant (no hysteresis)
Inaccuracy:	
- Starting	± 20 mHz
- Starting (LV block)	3% of the set value or ± 0.5 V
- Operate time	$\pm 1\%$ or ± 30 ms

Table 11.47: Rate of change of frequency (ROCOF) stage df/dt (81R)

Pick-up setting df/dt	0.2 – 10.0 Hz/s (step 0.1 Hz/s)
Definite time delay ($t_{>}$ and $t_{Min>}$ are equal): - Operate time $t_{>}$	0.14** – 10.00 s (step 0.02 s)
Inverse time delay ($t_{>}$ is more than $t_{Min>}$): - Minimum operate time $t_{Min>}$	0.14** – 10.00 s (step 0.02 s)
Start time	Typically 140 ms
Reset time	150 ms
Retardation time	< 90 ms
Reset ratio	1
Inaccuracy: - Starting - Operate time(overshoot ≥ 0.2 Hz/s)	10% of set value or ± 0.1 Hz/s ± 35 ms, when area is 0.2 – 1.0 Hz/s

NOTE: ROCOF stage is using the same low voltage blocking limit as the frequency stages.

11.3.10 Power protection

Table 11.48: Under-impedance stages $Z<$, $Z<<$ (21)

Pick-up value	$0.05 - 2.00 \times Z_N$
Definite time function:	
- Operate time	$0.08^{**} - 300.00$ s (step 0.02 s)
Start time	Typically 60 ms
Reset time	<95 ms
Retardation time	< 50 ms
Reset ratio	1.05
Inaccuracy:	
- Starting	± 4 % of set value or $\pm 0.01 \times Z_N$
- Operate time at definite time function	± 1 % or ± 30 ms

Table 11.49: Under-excitation stage $Q<$ (40)

Settings:	
- $Q@P0\%$, Reactive power limit at $P=0$ %	$-100 - 0$ % $\times S_{GN}$
- $Q@P80\%$, Reactive power limit at $P=80$ %	$-100 - 0$ % $\times S_{GN}$
Definite time function:	
- Operate time	$0.08^{**} - 300.00$ s (step 0.02 s)
Start time	Typically 60 ms
Reset time	$0.06 - 300.00$ s (step 0.02 s)
Retardation time	< 50 ms
Reset ratio	$0.98 (x S_{GN})$
Inaccuracy:	
- Starting	$\pm 3\%$ of set value or $\pm 0.5\%$ of S_{GN}
- Operate time	± 1 % or ± 30 ms

Table 11.50: Under reactance and loss of excitation stages $X<$, $X<<$ (40)

Trip area radius setting range	$0.05 - 2.00 \times Z_N$
Resistive offset Ros	$-2.00 - 2.00 \times Z_N$
Reactive offset Xos	$-2.00 - 2.00 \times Z_N$
Definite time function:	
- Operate time	$0.08^{**} - 300.00$ s (step 0.02 s)
Start time	<80 ms
Reset time	$0.08 - 300.00$ s (step 0.02 s)
Reset ratio	1.05
Inaccuracy:	
- Starting	± 4 % of set value or $\pm 0.01 \times Z_N$
- Operate time at definite time function	± 1 % or ± 30 ms

Table 11.51: Directional power stages $P<$, $P<<$ (32)

Input signal	$I_{L1} - I_{L3}$ $U_{L1} - U_{L3}$
Pick-up value	-200.0 – +200.0 % P_M (step 0.5)
Definite time function: - Operate time	0.3 – 300.0 s (step 0.1)
Start time	Typically 200 ms
Reset time	<500 ms
Reset ratio	1.05
Inaccuracy: - Starting - Operate time at definite time function	± 3 % of set value or ± 0.5 % of rated value ± 1 % or ± 150 ms

NOTE: When pick-up setting is +1 – +200% an internal block will be activated if max. voltage of all phases drops below 5% of rated.

11.3.11

Pole slipping stage (78)

Table 11.52: Pole slipping stage (78)

R setting forward	0.10 – 1.00 xZ_N
R setting reverse	0.10 – 1.00 xZ_N
X setting reverse	0.10 – 1.00 xZ_N
X setting reverse	0.10 – 1.00 xZ_N
I1 min setting	0.10 – 1.00 xZ_N
Number of pole slips	1 – 10
Time window	0.10 – 600.0 s

11.3.12 Synchrocheck function

Table 11.53: Synchrocheck function Δf , ΔU , $\Delta\phi$ (25)

Input signal	$U_{L1} - U_{L4}$
Sync mode	Off; Async; Sync;
Voltage check mode	DD; DL; LD; DD/DL; DD/LD; DL/LD; DD/DL/LD
CB closing time	0.04 – 0.6 s
U_{DEAD} limit setting	10 – 120 % U_N
U_{LIVE} limit setting	10 – 120 % U_N
Frequency difference	0.01 – 1.00 Hz
Voltage difference	1 – 60 % U_N
Phase angle difference	2° – 90°
Request timeout	0.1 – 600.0 s
Stage operation range	46.0 – 64.0 Hz
Reset ratio (U)	0.97
Inaccuracy:	
- Voltage	± 3 % U_N
- Frequency	± 20 mHz
- Phase angle	$\pm 2^\circ$ (when $\Delta f < 0.2$ Hz, else $\pm 5^\circ$)
- Operate time	$\pm 1\%$ or ± 30 ms

NOTE: When “sync” mode is used, Δf should be less < 0.2 Hz.

11.4 Supporting functions

***) This is the instantaneous time i.e. the minimum total operational time including the fault detection time and operation time of the trip contacts.

Table 11.54: Disturbance recorder (DR)

Mode of recording	Saturated / Overflow
Sample rate:	
- Waveform recording	32/cycle, 16/cycle, 8/cycle
- Trend curve recording	10, 20, 200 ms 1, 5, 10, 15, 30 s 1 min
Recording time (one record)	0.1 s – 12 000 min (According recorder setting)
Pre-trigger rate	0 – 100%
Number of selected channels	0 – 12

The recording time and the number of records depend on the time setting and the number of selected channels.

Table 11.55: Inrush current detection

Cold load settings:	
- Idle current	$0.01 - 0.50 \times I_N$
- Pickup current	$0.30 - 10.00 \times I_N$
- Maximum time	$0.01^{**} - 300.00 \text{ s}$ (step 0.01 s)
Inrush settings:	
- Pickup for 2nd harmonic	0 – 99 %

Table 11.56: Current transformer supervision

$I_{MAX}>$ setting	$0.00 - 10.00 \times I_N$ (step 0.01)
$I_{MIN}<$ setting	$0.00 - 10.00 \times I_N$ (step 0.01)
Definite time function:	
- Operate time	$0.04 - 600.00 \text{ s}$ (step 0.02 s)
Reset time	< 60 ms
Reset ratio $I_{MAX}>$	0.97
Reset ratio $I_{MIN}<$	1.03
Inaccuracy:	
- Activation	$\pm 3\%$ of the set value
- Operate time at definite time function	$\pm 1\%$ or $\pm 30 \text{ ms}$

Table 11.57: Voltage transformer supervision

U ₂ > setting	0.0 – 200.0 % (step 0.1%)
I ₂ < setting	0.0 – 200.0 % (step 0.1%)
Definite time function:	DT
- Operate time	0.04 – 600.00 (step 0.02s)
Reset time	< 60 ms
Reset ratio	3% of the pick-up value
Inaccuracy:	
- Activation U ₂ >	±1%-unit
- Activation I ₂ <	±1%-unit
- Operate time at definite time function	±1% or ±30 ms

Table 11.58: Voltage sag & swell

Voltage sag limit	10 – 120 %U _N (step 1%)
Voltage swell limit	20 – 150 %U _N (step 1%)
Definite time function:	DT
- Operate time	0.08 – 1.00 s (step 0.02 s)
Low voltage blocking	0 – 50 %
Reset time	< 60 ms
Reset ration:	
- Sag	1.03
- Swell	0.97
Block limit	0.5 V or 1.03 (3 %)
Inaccuracy:	
- Activation	±0.5 V or 3% of the set value
- Activation (block limit)	±5% of the set value
- Operate time at definite time function	±1% or ±30 ms

If one of the phase voltages is below sag limit and above block limit but another phase voltage drops below block limit, blocking is disabled.

Table 0.1: Voltage interruptions

Voltage low limit (U ₁)	10 – 120 %U _N (step 1%)
Definite time function:	DT
- Operate time	<60 ms (Fixed)
Reset time	< 60 ms
Reset ratio	1.03
Inaccuracy:	
- Activation	3% of the set value

12 Mounting

VAMP 300 PROJECTION MOUNTING

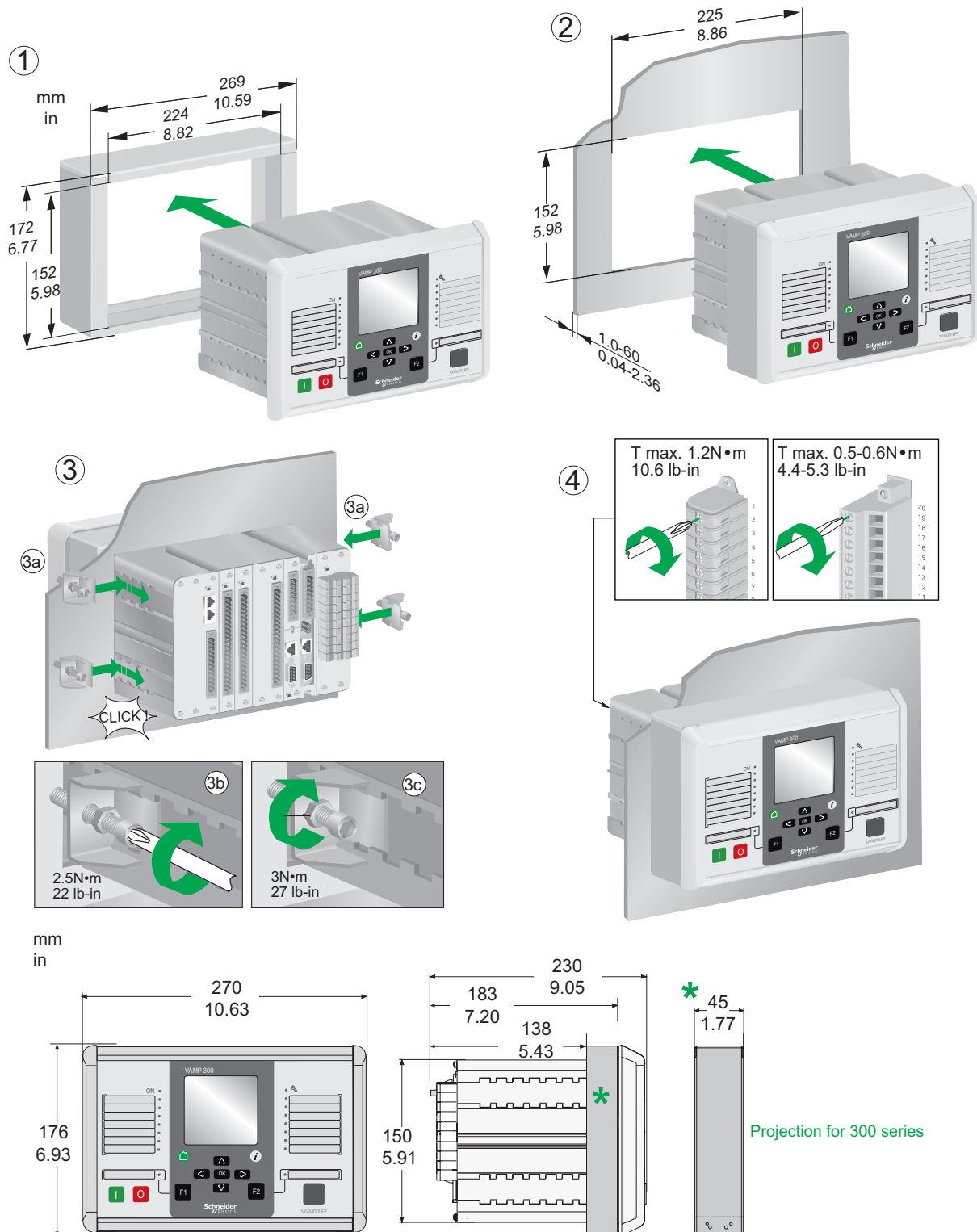

In case the depth dimension behind the compartment door is limited, the device can be equipped with frame around the collar. This arrangement reduces depth inside compartment by 45 mm. More details please see Table 11.15.

VAMP 300 PANEL MOUNTING

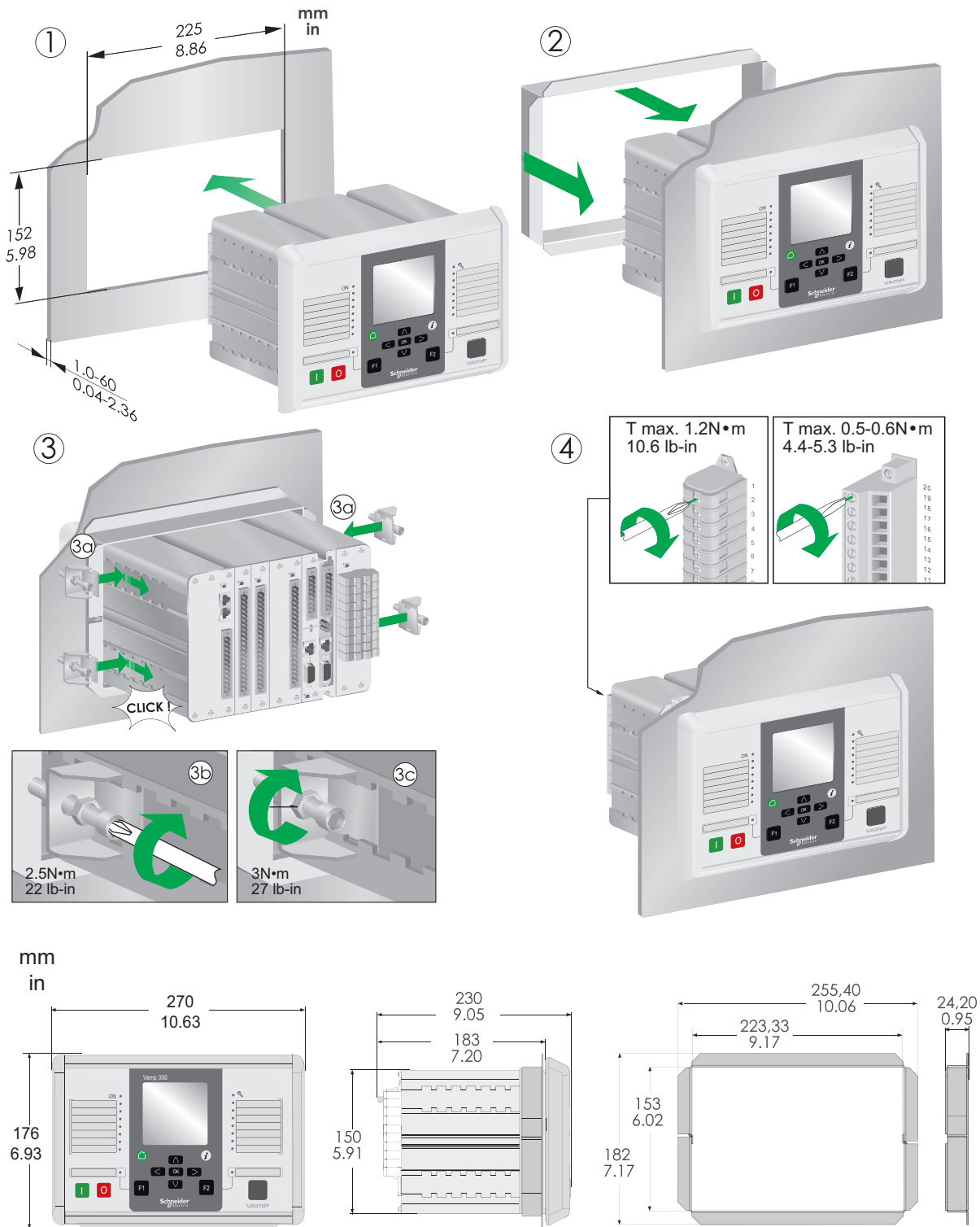

The conventional mounting technique has always been installing the device on the secondary compartment's door. Limitation in this approach could be that the door construction is not strong enough for the device's weight and suitability to wire large amount of secondary and communication cabling could be challenging.

VAMP 300 WALL MOUNTING WITH DETACHABLE HMI

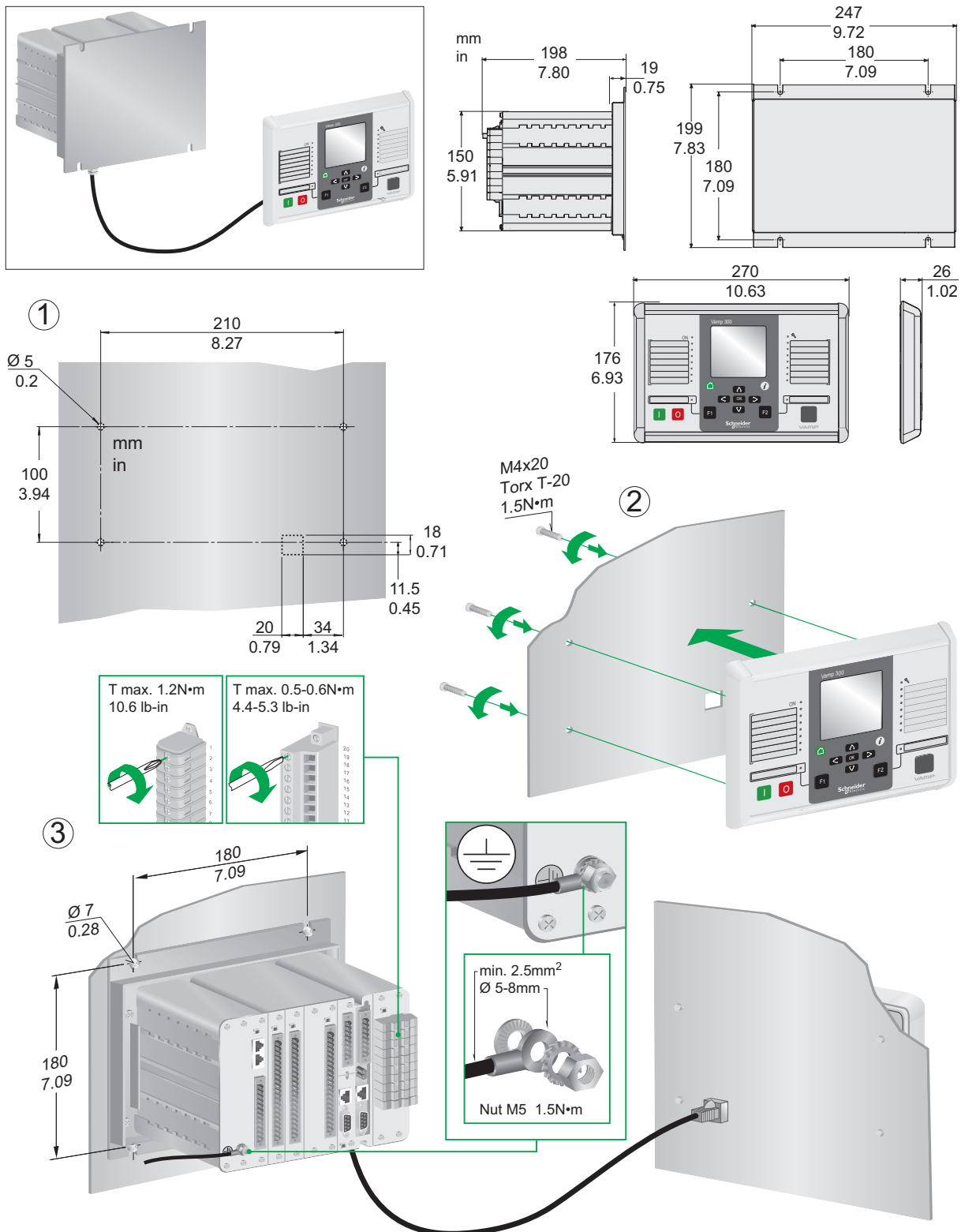

This mounting technique allows door being lighter as the relays frame is installed in the back of the secondary compartment. Normally, the device in this mounting principle is by the terminal blocks, hence the secondary wiring is short. Communication cabling is easier, too, as the door movement does not need to be considered. In this case, only the communication between device base and display has to be wired.

13 Order information

When ordering, please state:

- Type designation:
- Quantity:
- Accessories (see respective ordering code):

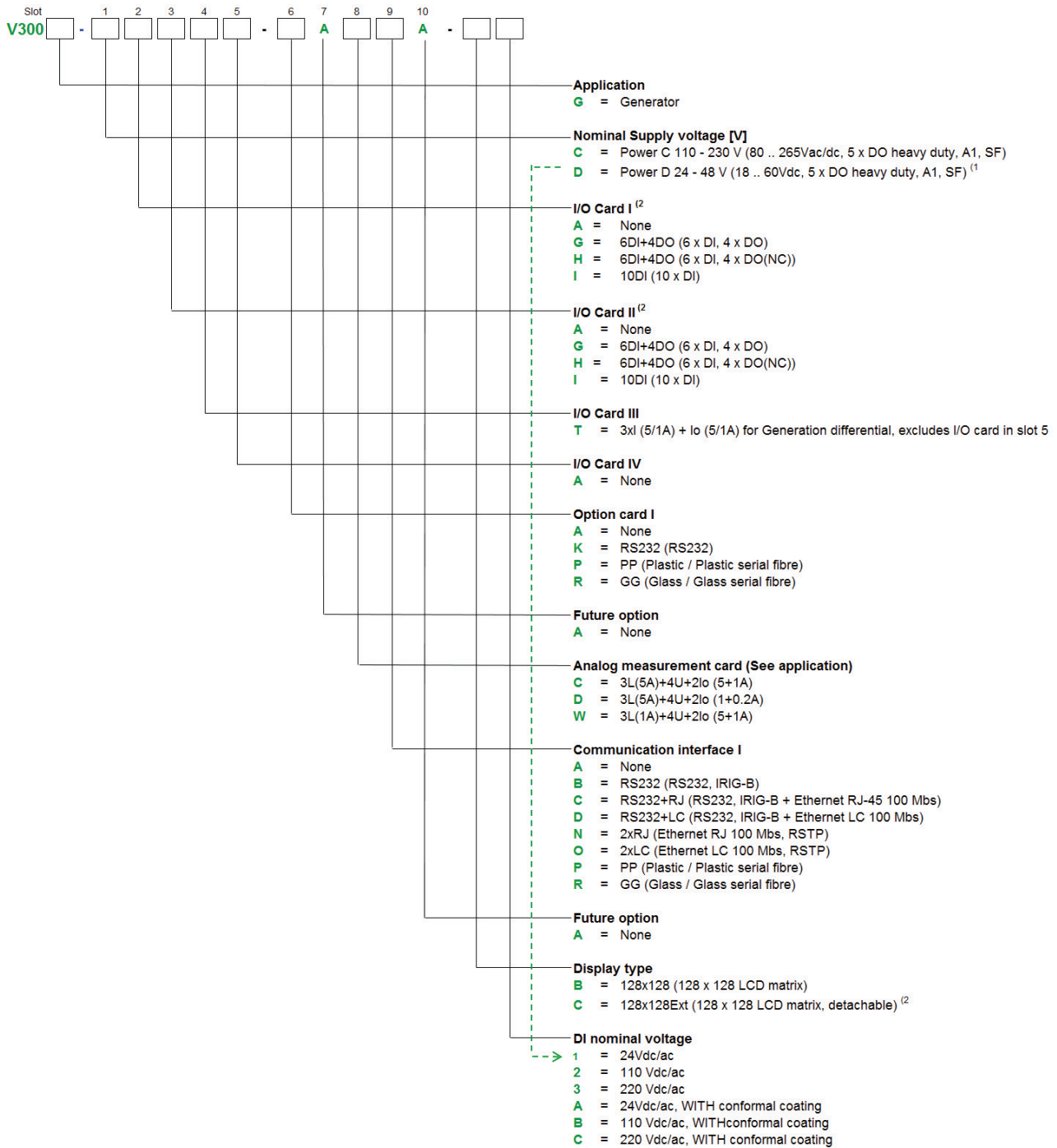

NOTE:

(1: By default cable length is 2 m. In case other length is needed order separately VX001-1, Vx001-3 or VX001-5 for 1 m, 3 m and 5 m respectively.

(2: Optional I/O cards for slots 2-5 have to be chosen in the following order: G modules first and then I or H modules

(3: By default cable length is 2 m. In case other length is needed order separately VX001-1, Vx001-3 or VX001-5 for 1 m, 3 m and 5 m respectively.

Accessories

Order code	Description	Note
VX052-3	USB programming cable (VAMPSET)	Cable length 3 m (9.85 ft)
VX067	VAMP 300/321 split cable for COM1-2 and COM 3-4 ports	Cable length 3 m (9.85 ft)
VSE001PP	Fibre optic Interface Module (plastic - plastic)	Max. distance 30 m (99 ft)
VSE001GG	Fibre optic Interface Module (glass - glass)	Max. distance 1 km (0.63 miles)
VSE001GP	Fibre optic Interface Module (glass - plastic)	Max. distance 1 km / 30 m (0.63 miles / 99 ft)
VSE001PG	Fibre optic Interface Module (plastic - glass)	Max. distance 30 m / 1 km (99 ft/0.63 miles)
VSE002	RS485 Interface Module	
VSE009	External DeviceNet interface module	
VPA 3CG	Profibus DP fieldbus option board	
VX072	VAMP 300/321 profibus cable	Cable length 3 m (9.85 ft)
VIO 12 AB	RTD Module, 12 x RTD inputs, RS 485 Communication (24-230 Vac/dc)	
VIO 12 AC	RTD/mA Module, 12 x RTD inputs, PTC, mA inputs/outputs, RS232, RS485 and Optical Tx/Rx Communication (24 Vdc)	
VIO 12 AD	RTD/mA Module, 12 x RTD inputs, PTC, mA inputs/outputs, RS232, RS485 and Optical Tx/Rx Communication (48-230 Vac/dc)	
VYX 695	Projection for 300-series	Height 45 mm (1.78 in)



Customer Care Centre

<http://www.schneider-electric.com/CCC>

Schneider Electric

35 rue Joseph Monier
92500 Rueil-Malmaison
FRANCE

Phone: +33 (0) 1 41 29 70 00

Fax: +33 (0) 1 41 29 71 00

www.schneider-electric.com

Publication version: V300G/en M/A006

Publishing: Schneider Electric

01/2018