

# VAMP 50 series

with native IEC 61850 and arc flash protection



The VAMP 50 series protection relay family is based on proven technology concepts developed in close cooperation with customers. Vamp products have been designed around user-friendliness, a feature which is proven in our customer reports day after day.

The VAMP 50 overcurrent and earth fault protection relay has been developed to cover basic protection needs for OEMs, utilities and industrial applications. Thanks to its cost-effective and flexible design, the Vamp 50 provides an excellent alternative for various protection applications.

Vamp 52 combines further protection functions such as directional earth fault for feeder and motor protection.



Arc flash sensors connected in the advanced arc option module typically trips the breaker within 7 ms.



## CUSTOMER BENEFITS

### Robust and flexible hardware

- Modular design with versatile hardware expansion for communication, arc protection and digital I/O extension
- Designed for demanding industrial conditions
- Slimline models available

### Common technology for cost efficiency

- Powerful CPU supporting native IEC 61850
- Utilisation of common VAMP platform accessories
- Improved safety with economical and fast arc flash protection (optional)

### User-friendly and high functionality

- Common firmware platform with VAMP 200 and 300 Series
- Only active functions visible for the operator
- Standard USB connection (type B) for setting software (VAMPSET)

### Modern Human Machine Interface (HMI)

- Large and clear LCD display
- Single line diagram mimic with control, indication and live measurements
- Programmable function keys and LEDs

# VAMP 50 family: low and mid range relay series with IEC 61850

## EASE OF USE

User-friendliness has always been a feature of VAMP products, and the VAMP 50 series is no exception. A great deal of effort has gone into the design of the operational aspects of the new products.

The rapid setting and download/upload is achieved with the unique VAMPSET setting software which dramatically improves usability. Unicode support allows the menu text and settings to be translated into various international languages including for example Russian and Chinese. The informative human machine interface shows all of the required information for the user with support of customised legend texts.



## VAMP 50 FAMILY HMI INTERFACE

**Navigation push buttons**

**Function buttons with:**

- User configurable legend texts
- CB control
- Protection setting group selection
- Freely programmable

**Programmable LEDs**

- User configurable legend texts
- 12 LEDs, 2 fixed (power, error) and 8 freely programmable (2 for push buttons)

**128 x 64 LCD**

**dot matrix display**

- Single line diagram and freely assignable analogue values
- Unicode language support

**Local port**

- USB interface



The template for user legend texts is a part of the product documentation.

The texts are printed on a transparent film allowing customisation of the relay.

**Two optional module slots**

- Extends the functionality of the relay
- Remote port: RS485, RS232 & Ethernet (RJ-45 or fibre)
- Arc, DI/DO

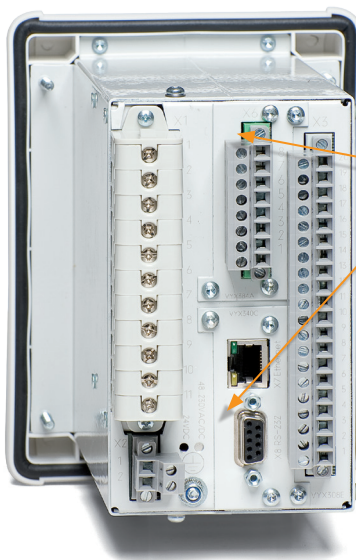

# Enhanced usability

The VAMP 50 protection relay concept has been extended with a number of features that make installation and testing of the relays even more efficient and user-friendly.

## VAMP 50S – COMPACT DESIGN FOR LIMITED SPACE

The VAMP 50 series is now also available as the VAMP 50S, which includes a more compact case than the basic design. The VAMP 50S is an ideal choice for ring main unit switchgear and other applications where a horizontal mounted relay is required.

In the VAMP 50S, the protection, measurement and control functions and communication interfaces are identical to the basic 50 series of relays.

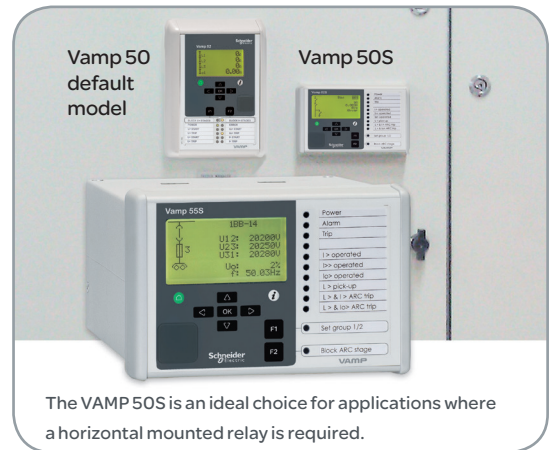

The VAMP 50S is an ideal choice for applications where a horizontal mounted relay is required.

# Communication for Vamp 50 / 52 / 55

Vamp is an expert in communication with vast experience in interfacing different system integrators, SCADA, RTUs, PLCs and gateways using a large number of supported protocols. Flexible adaptation of the communication protocols together with powerful and easy to use software tools are the key to successful integration. VAMP 50 series and the VAMPSET tool provide access to practically any power system information you may need.

## NATIVE IEC 61850

The IEC 61850 protocol can be used to read or write static data or to receive events sent spontaneously from the relay. In addition, the interface allows peer-to-peer communication between the relays, known as GOOSE. The IEC 61850 interface is configured with familiar, user-friendly VAMPSET software.

The IEC 61850 datamodel, data-sets, report control blocks and GOOSE communication are configured according to the requirements of the system configuration. VAMPSET is also used to produce ICD files, which may be needed for the substation integration.

The Vamp 50 series IEC61850 implementation is native, which means the functionality is integral to the product design and software, providing fast and efficient operation.

## VAMP 50 COMMUNICATION PROTOCOLS

- IEC 60870-5-101
- IEC 60870-5-103
- Modbus TCP
- Modbus RTU
- Profibus DP
- DNP 3.0
- SPA-bus communication
- IEC 61850
- Device Net
- Human-Machine-Communication, display
- Human-Machine-Communication, PC

Communication Type, Connector and Communication Port for optional communication module 1

Comm. Module 1	Comm. Type	Type of connector	Comm. Port
A		No communication option.	
D	Serial	Plastic / Plastic Fiber	Remote
E	Serial	Glass / Glass Fiber	Remote
F	Serial	Rx Plastic / Tx Glass Fiber	Remote
G	Serial	Rx Glass / Tx Plastic Fiber	Remote
K	Serial	D9	Remote Extension*
	Ethernet	RJ-45	TCP / IP (10 Mbps)
P	Serial (Profibus)	D9	Remote
R	Ethernet	ST (x2)	TCP / IP (100Mbps)
S	Ethernet	RJ-45 (x2)	TCP / IP (100Mbps)
B	Serial	3-Pole screw	Remote
L	Serial	D9	Remote
			Extension
M	Serial	D9	Remote
			Extension

\* Not compatible with Extension port in module M (different pin order).

All possible combinations for Communication Module 1 and Communication Module 2

Module 1	Module 2
A	A
D	A
E	A
F	A
K	A
P	A
R	A
S	A
B	A
	B
	C
	E
L	A
	B
	C
	E
M	A
	B
	C**
	E
	G

\*\* Note that Extension port will be only available through one interface at the time (D9 or Glass Fiber).

Communication Type, Connector and Communication Port for optional communication module 2

Comm. Module 2	Comm. Type	Type of connector	Comm. Port
A		No communication option.	
B	IRIG-B (Clock Sync)	2-Pole screw	***
C	Serial (RTD Interface)	Glass fiber	Extension
E	Ethernet	RJ-45	TCP / IP (10 Mbps)
G	Ethernet	LC	TCP / IP (100Mbps)

\*\*\* Does not apply.





# Arc flash protection

When traditional time-grading or blocking protection coordination principle is used, it may not provide fast enough protection of substation faults. Further, high-impedance type of earth-faults may cause prolonged operation times of earth-fault relays leading to the significant release of arcing energy. These facts pose a considerable risk to operation personnel and economical assets. By applying a modern, high-speed arc protection system the damage may be considerably reduced. Such an arc protection system is an optional feature that can be incorporated in all current measuring VAMP relays.

VAMP relays measure fault current and with optional arc protection, also measure light via arc sensor channels, which provide monitoring for the whole switchgear. Should an arc fault occur in the switchgear the arc protection system provides extremely fast tripping of the circuit breaker. The fault will be prevented from spreading and quickly isolated, which may save

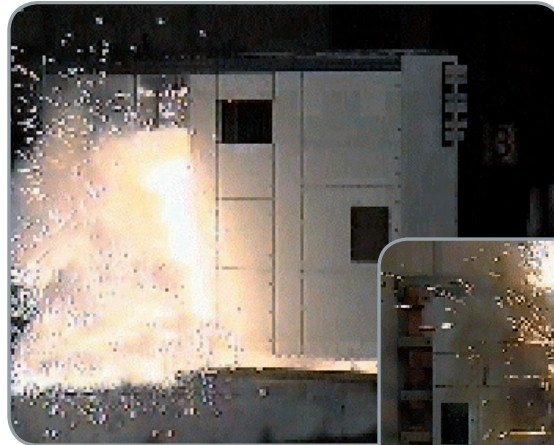

Traditional protection relay systems do not provide fast enough protection in arc-fault situations.

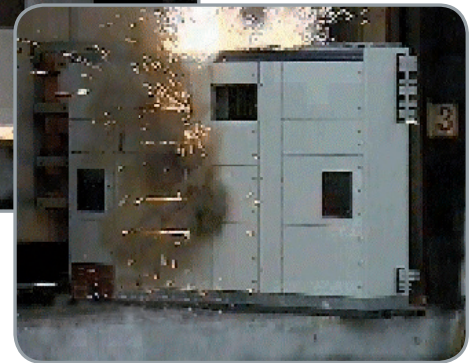

## ARC POINT SENSORS

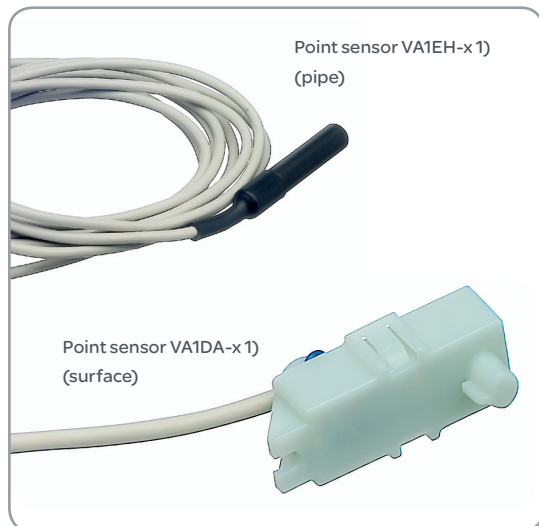

The optional integrated arc protection system may extend the lifetime of the switchgear.

Arc flash protection integrated in VAMP relays enables substation level, ultra-fast arc protection. The system uses protection relay hardware and separate arc sensors. Any arc flash fault in the cable compartment is selectively cleared by the feeder protection relay. Any arc flash fault in the circuit breaker or busbar compartment is tripped by the incoming circuit breaker. The exact location of the arc flash will be detected by the arc flash and relay protection system.

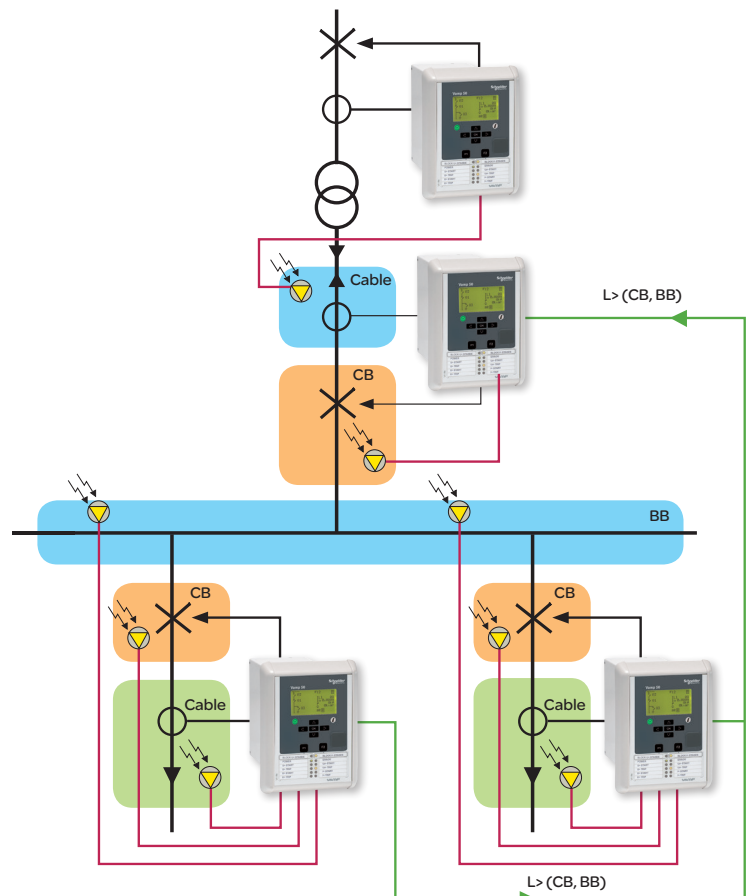

# VAMPSET Setting and Configuration Tool

VAMPSET is a user-friendly, free-of-charge relay management software for setting parameters and configuring VAMP relays. Via the VAMPSET software, relay parameters, configurations and recorded data can be exchanged between PC and VAMP relays. Supporting the COMTRADE format, VAMPSET also incorporates tools for analysing relay events, waveforms and trends from data recorded by the relays, e.g. during a network fault situation.



Standard USB communication cable can be used.

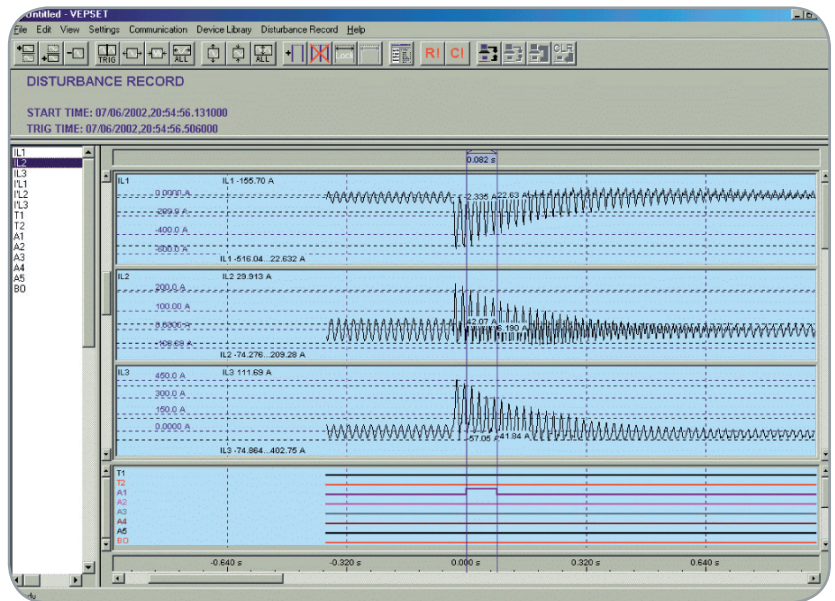

VAMP relays support standard COMTRADE type disturbance recording files which can be uploaded/downloaded for evaluation of any network event recorded.

Using a standard serial cable the PC running VAMPSET connects to the front port of the VAMP relays. The VAMPSET software also supports TCP/IP communication via an optional port. Featuring true multi-language support the software runs on Windows 7 / Vista / XP / 2000 / NT and Windows 98 / 95 without any need for configuration of the PC.

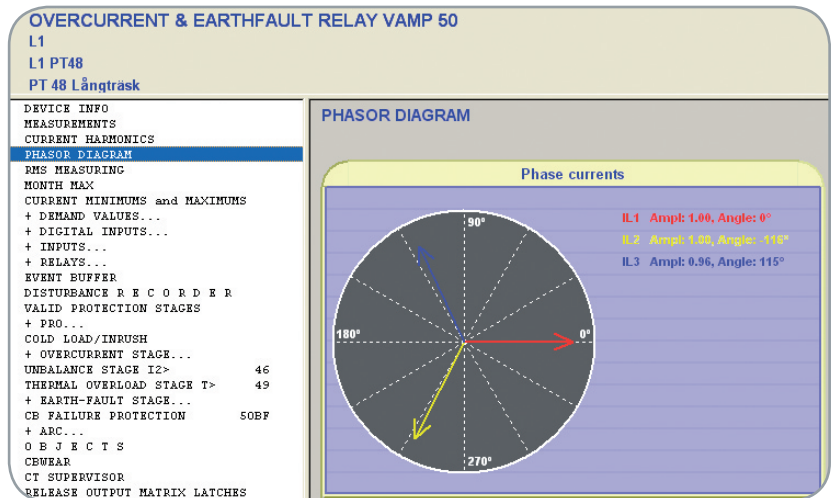

The phase sequences for currents and voltages can be read on-line from the clear and explicit phasor diagram screen for easy commissioning of the relay.

The VAMPSET software is future-proof, supporting future updates and new VAMP products.

## INPUT/OUTPUT OPTIONS

The VAMP 50 series host various optional modules in order to upgrade the relay functionality from basic to more advanced applications.

	VAMP 50	VAMP 52	VAMP 55
Analog inputs	3 x I 1 x Io	3 x I 1 x Io, 1 x U	4 x U
Digital inputs	2 (7)	2 (7)	2 (7)
Trip relays	4 (5)	4 (5)	4 (5)
Control relays	1	1	1
mA output	Option	Option	Option
Arc protection	Option	Option	-
Front port	USB	USB	USB
Optional rear port	RS 485/RS 232/ Fibre/Ethernet	RS 485/RS 232/ Fibre/Ethernet	RS 485/RS 232/ Fibre/Ethernet
External RTD input module	Option	Option	Option

# Measurements and condition monitoring

The VAMP 50 series offers a complete set of measurement functions to replace the conventional metering functions of switchgear and controlgear installations. The measurement functions cover phase, line and residual currents, current imbalance, system frequency and harmonics from phase currents. Condition monitoring continuously monitors trip circuits, breaker wear and current

Type of measurement	IEC Symbol	Protection function / measurement	Feeder protection		Motor protection	Special applications
			VAMP50	VAMP52	VAMP52	VAMP55
Primary current	3I	Three-phase current	●	●	●	
	3I <sub>0</sub>	Zero sequence current	●	●	●	
	I <sub>2</sub>	Current unbalance	●	●	●	
	IL	Average and maximum demand current	●	●	●	
Primary voltage	U/3U	One/ three-phase and line voltage		①	①	③
	U <sub>0</sub>	Zero sequence voltage		●	●	●
	U <sub>2</sub> / U <sub>1</sub>	Relative voltage unbalance				●
Frequency	f	System frequency	●	●	●	●
Harmonics	I	2nd to 15th and THD of phase currents	●	●	●	
	U	2nd to 15th and THD of measured voltages		①	①	③
Voltage sags / swells	U	Voltage sags / swells		①	①	③
Analog mA output, 1 channel	AO	Any measured or calculated value, freely scalable, optional	●	●	●	●

Control						
Digital inputs		Number of digital inputs (max)	7	7	7	7
Output relays		Number of trip relays (max)	5	5	5	5
		Number of alarm relays	1	1	1	1
Object status indication		Single line diagram, 8 objects	8	8	8	8
Local and remote control		Number of controllable objects	6	6	6	6
Interlocking and logic		Configurable	●	●	●	●

Condition monitoring						
Trip circuit	TCS	Trip Circuit Supervision	●	●	●	●
	TCS	Trip Circuit Supervision with DI for T5...T8	●	●	●	●
CT Supervision		CT Supervision	●	●	●	
VT Supervision		VT Supervision/Fuse failure supervision				●
CB wear		Breaker wear	●	●	●	

# Protection stages

User-friendliness is also a built-in feature of protection stages, where setting views are graphically displayed in the relay and VAMPSET HMI. Disabled protection stages are hidden from the menu in order to display only the necessary information. Protection stages come with two setting groups to enable automatic transfer from main setting to alternative setting. This change can be universal for the entire relay or based on protection function.

The relay has a large number of standard inverse curves to adopt various protection requirements. Unique protection curves can be applied when standard IEC or IEEE curves do not provide required protection selectivity.

Type of fault.	IEEE Device No.	IEC Symbol	Protection function / measurement	Protection			
				Feeder		Motor	Voltage
				50	52	52	55
Short circuit	50/51	3I >	Three-phase non-directional overcurrent, low-set stage, definite or inverse time	●	●	●	
	50/51	3I >>	Three-phase non-directional overcurrent, high-set stage, definite time	●	●	●	
	50/51	3I >>>	Three-phase non-directional overcurrent, high-set stage, definite time	●	●	●	
Earth-fault	50N/51N	I <sub>0</sub> >	Non-directional earth-fault, low-set stage, sensitive, definite or inverse time	●	●	●	
	50N/51N	I <sub>0</sub> >>	Non-directional earth-fault, high-set stage, definite time	●	●	●	
	50N/51N	I <sub>0</sub> >>>	Non-directional earth-fault, high-set stage, definite time	●	●	●	
	50N/51N	I <sub>0</sub> >>>>	Non-directional earth-fault, high-set stage, definite time	●	●	●	
	67N-IEF	I <sub>0T</sub>	Intermittent transient intermittent earth-fault protection	●	●		
	67N or 50N/51N	I <sub>0φ</sub> >	Directional or non directional earth-fault, low-set stage, sensitive, definite or inverse time		●	●	
	67N or 50N/51N	I <sub>0φ</sub> >>	Directional or non dir. earth-fault, high-set stage, definite or inverse time		●	●	
	59N	U <sub>0</sub> >	Residual overvoltage, low-set stage		●	●	●
59N	U <sub>0</sub> >>	Residual overvoltage, high-set stage		●	●	●	
50N/51N	U <sub>0</sub> >>>	Residual overvoltage, high-set stage				●	
59N	U <sub>0</sub> >>>>	Residual overvoltage, high-set stage	●	●	●		
59N	U <sub>0</sub> >>>>>	Residual overvoltage, high-set stage	●	●	●		
50N/51N	REF	Restricted earth fault (application)	●	●	●		
Overload	49M	T >	Three-phase thermal overload (motors & generators)			●	
	49F	T >	Three-phase thermal overload (feeders & cables)	●	●		
Voltage	59	1U >/3U >	One-/three-phase overvoltage, low-set stage		①	①	③
	59	1U >>/3U >>	One-/three-phase overvoltage, high-set stage		①	①	③
	59	1U >>>/3U >>>	One-/three-phase overvoltage, high-set stage		①	①	③
	59	3U >>>>	Three-phase overvoltage, high-set stage				③
	59	3U >>>>>	Three-phase overvoltage, high-set stage				③
	24	U <sub>1</sub> >, U <sub>1</sub> >>	Volts/hertz overexcitation protection				●
	27	1U </3U <	One-/three-phase undervoltage, low-set stage		①	①	③
	27	1U <</3U <<	One-/three-phase undervoltage, high-set stage		①	①	③
	27	1U <<</3U <<<	One-/three-phase undervoltage, instantaneous stage		①	①	③
	27	3U <<<<	Three-phase undervoltage, instantaneous stage				③
	27	3U <<<<<<	Three-phase undervoltage, instantaneous stage				③
	27P	U <sub>1</sub> <, U <sub>1</sub> <<, U <sub>1</sub> <<<	Three-phase undervoltage, instantaneous stage stage for generator applications				●
	47	U <sub>2</sub> >, U <sub>2</sub> >>, U <sub>2</sub> >>>	Negative sequence overvoltage				●
	Arc protection	50ARC/50NARC	3I <sub>1</sub> > / I <sub>0</sub> >, L >	Electrical arc protection stage, point sensors, optional	●	●	●
79		O --> I	Auto-reclosure	●	●		
Other functions	68		Inrush and cold load detection	●	●	●	
	46	I <sub>2</sub> / I <sub>1</sub> >	Current unbalance protection (in feeder mode)	●	●		
	46	I <sub>2</sub> >	Phase unbalance protection (in motor mode)			●	
	47	I <sub>2</sub> >>	Phase sequence / incorrect phase sequence protection			●	
	48		Excessive starting time			●	
	37	3I <	Loss of load / under current protection		●	●	
	86		Latched trip	●	●	●	●
	66		Restart inhibit			●	
	32	P </P <<	One-/Three-phase reverse power and underpower protection		①	①	
	68F2	I <sub>p</sub> >	Magnetising inrush	●	●	●	
	68F5	I <sub>m</sub> >	Transformer overexcitation	●	●	●	
	50BF	CBFP	Circuit breaker failure protection	●	●	●	
	81H/81L	f >, f >><<	Overfrequency and underfrequency protection				●
	81H/81L	f >>><<<	Overfrequency and underfrequency protection				●
	81L	f <, f <<	Underfrequency protection				●
	81L	f <<<	Underfrequency protection				●
	81R	df/dt	Rate of change of frequency (ROCOF) protection		●		●
	25	Δf, ΔU, Δφ	Synchrocheck				●
	99		8 Programmable stages		●	●	●
		DR	Disturbance recorder	●	●	●	●

① = number of voltage channels

# VAMP 50 overcurrent and earth fault relay

**VAMP 50** is a basic protection relay used for LV and MV feeders in industrial and utility applications, as well as for back-up protection.

The limited amount of protection functions make this unit cost-efficient, user-friendly and easy to use. The hardware design allows simple addition of integrated optional modules like arc sensor interface, extension of DI / DO channels and various communication modules.



In addition to the default model, VAMP 50 series relays are also available as a slimline (S)

Typical application / VAMP 50, feeder mode

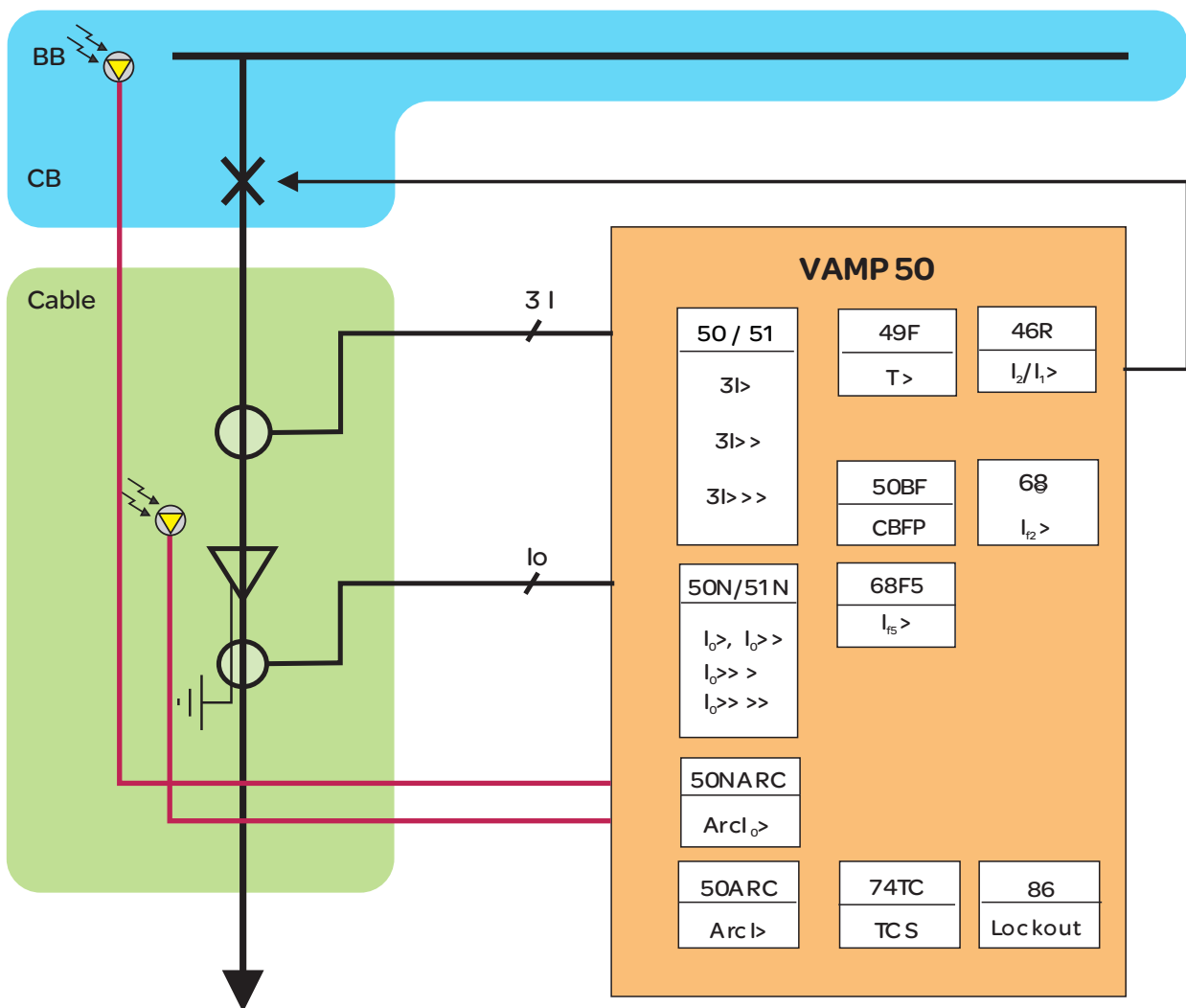



VAMP 50 CONNECTION DIAGRAM

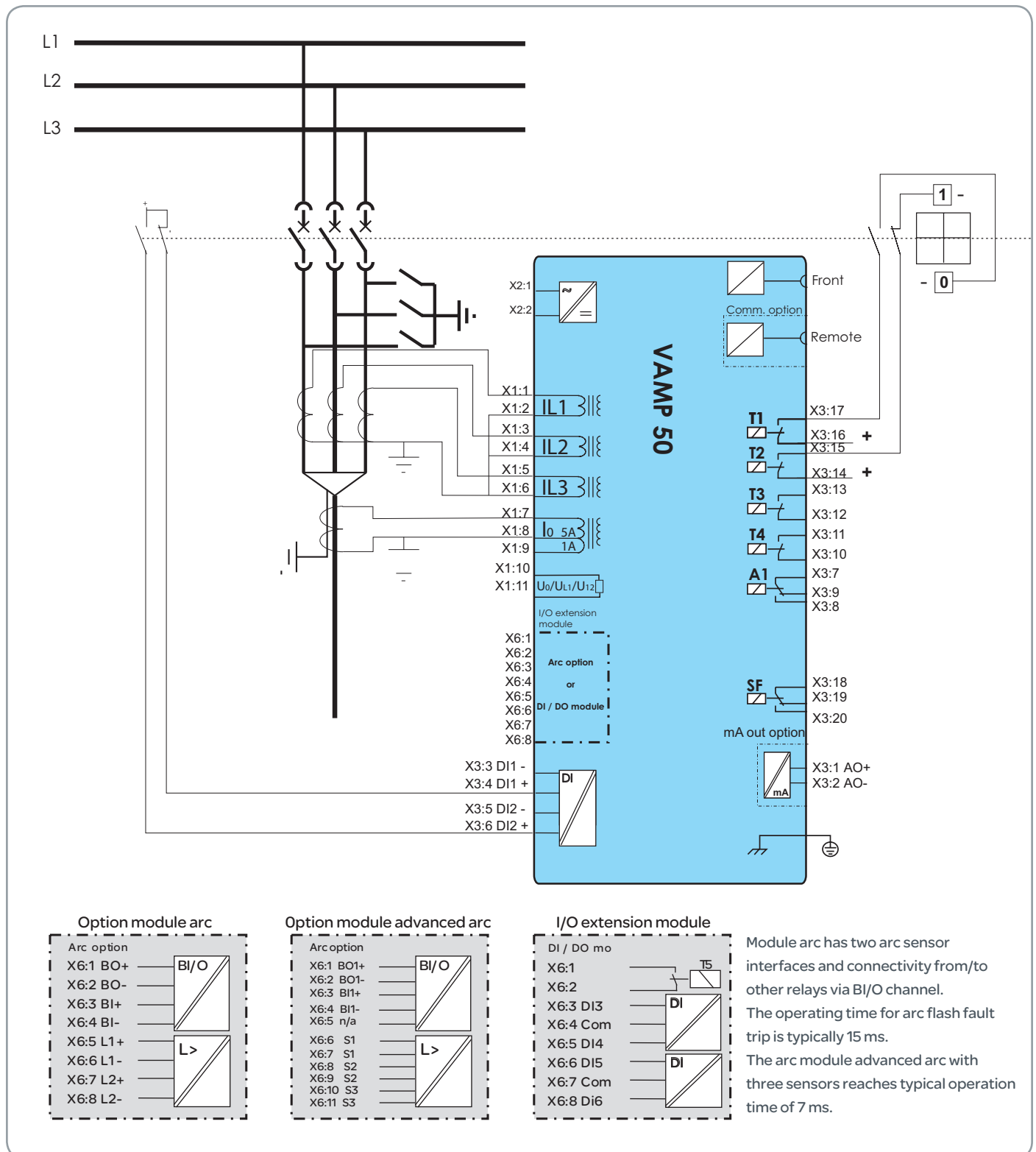

# VAMP 52 feeder and motor protection relay

VAMP 52 is a multi-function relay used for LV and MV feeders in industrial or utility applications.

Extensive thermal protection functions make this relay optimal for low and medium sized asynchronous motors. Directional earth fault protection in association with autoreclose function makes this relay cost effective for feeder protection applications where automatic fault clearance is needed.

Vamp 52 is flexible, user-friendly and easy to use. The hardware design allows simple addition of integrated optional modules like arc sensor interface, extension of DI / DO channels and various communication modules.

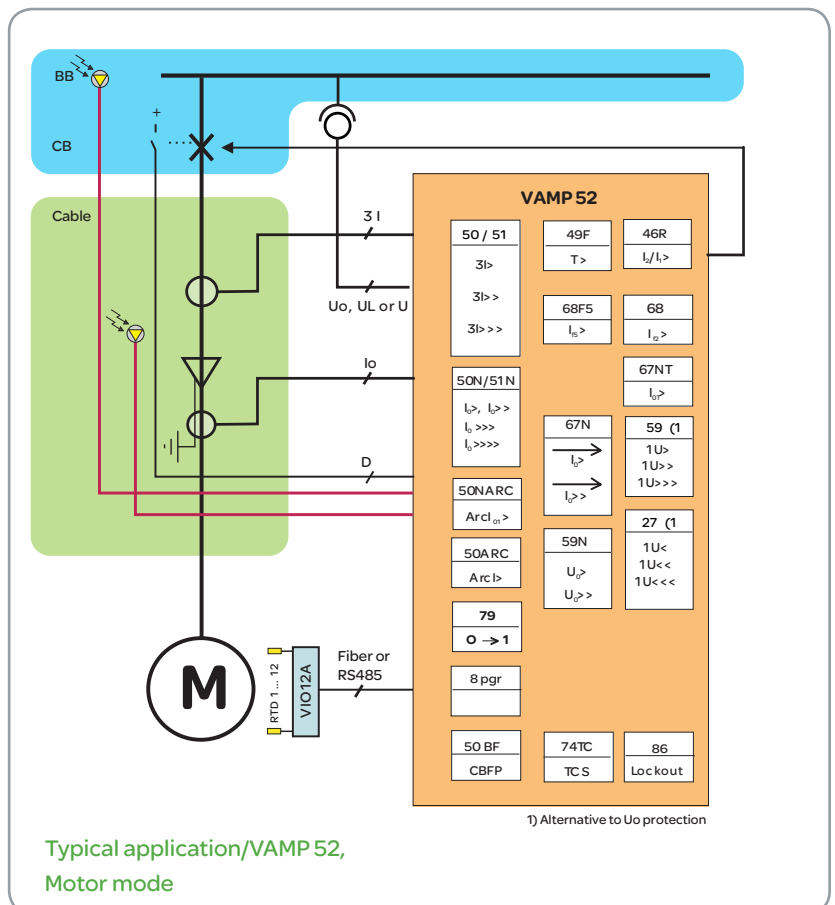
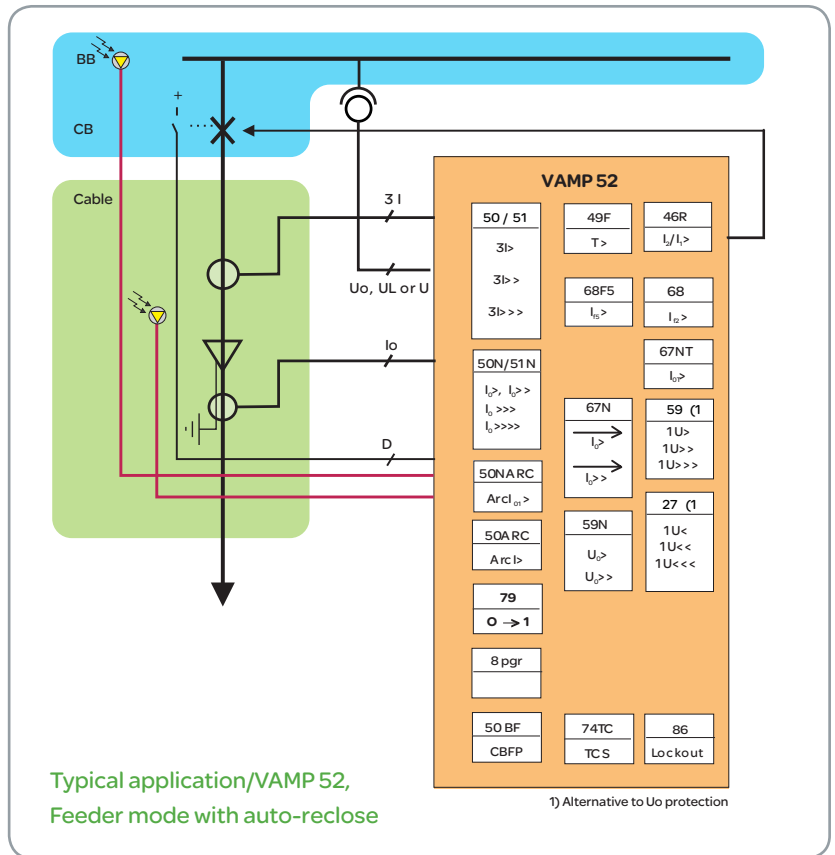

VAMP 52 CONNECTION DIAGRAM

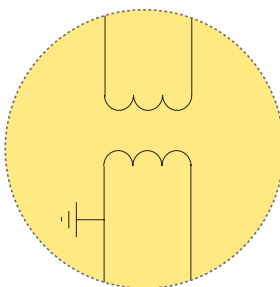
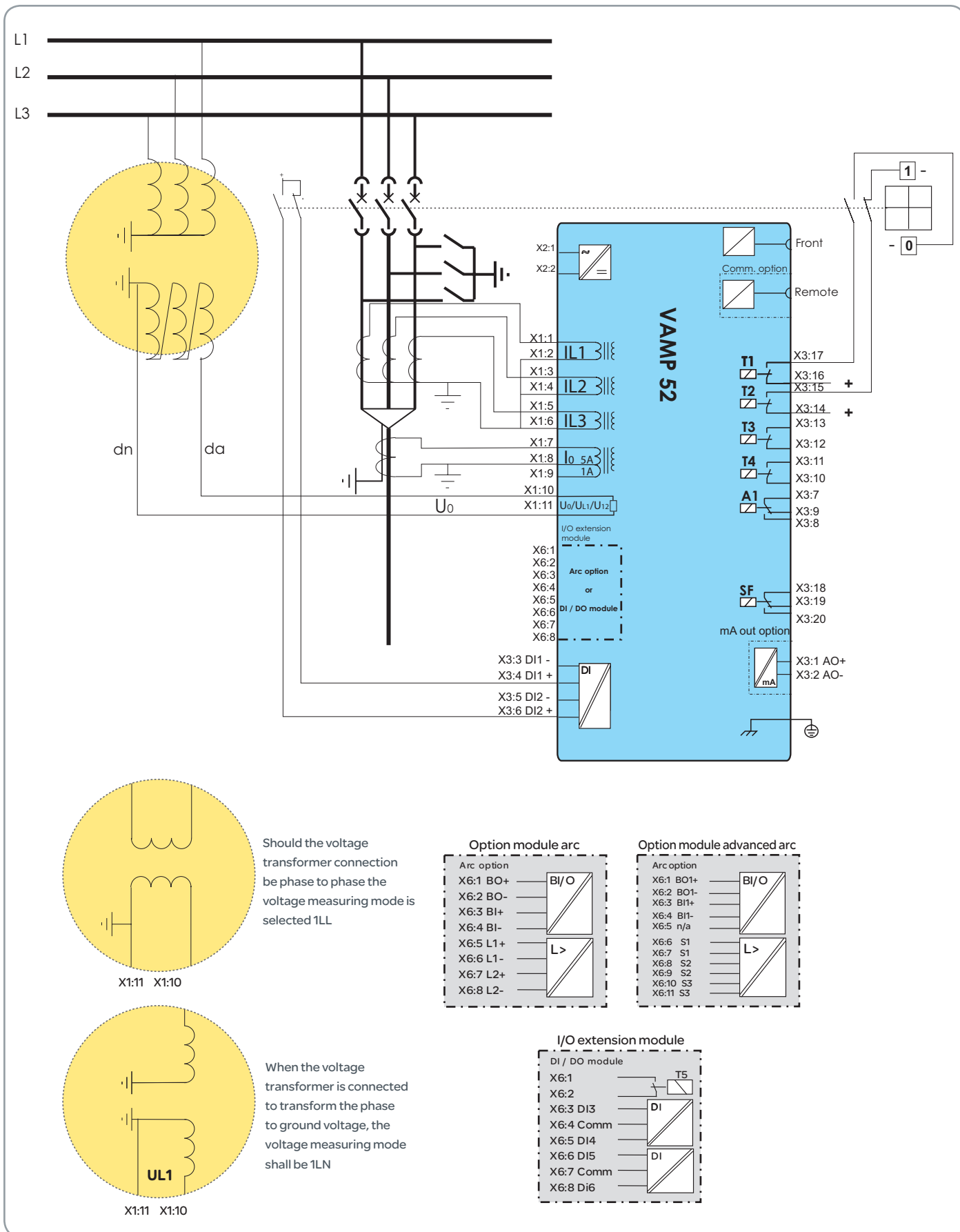

X1:11 X1:10

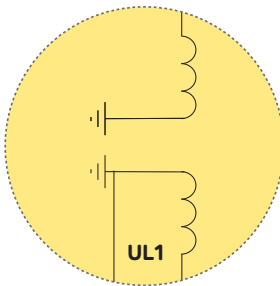

X1:11 X1:10

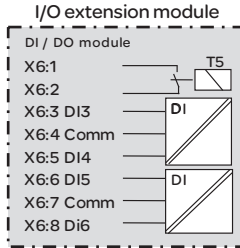
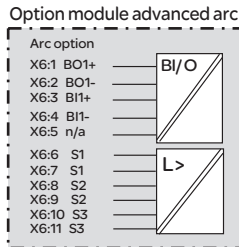
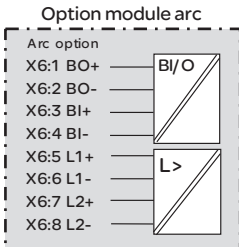

# VAMP 55 voltage protection relay

The VAMP 55 is a multi-function relay suitable for voltage and frequency protection for both utility and industrial applications and also for synchrocheck applications.

The relay is equipped with 4 voltage inputs that can be configured with any of the available predefined voltage mode setups.



The VAMP 55 relay is also available as a slimline (S) version.

## Typical application/VAMP 55

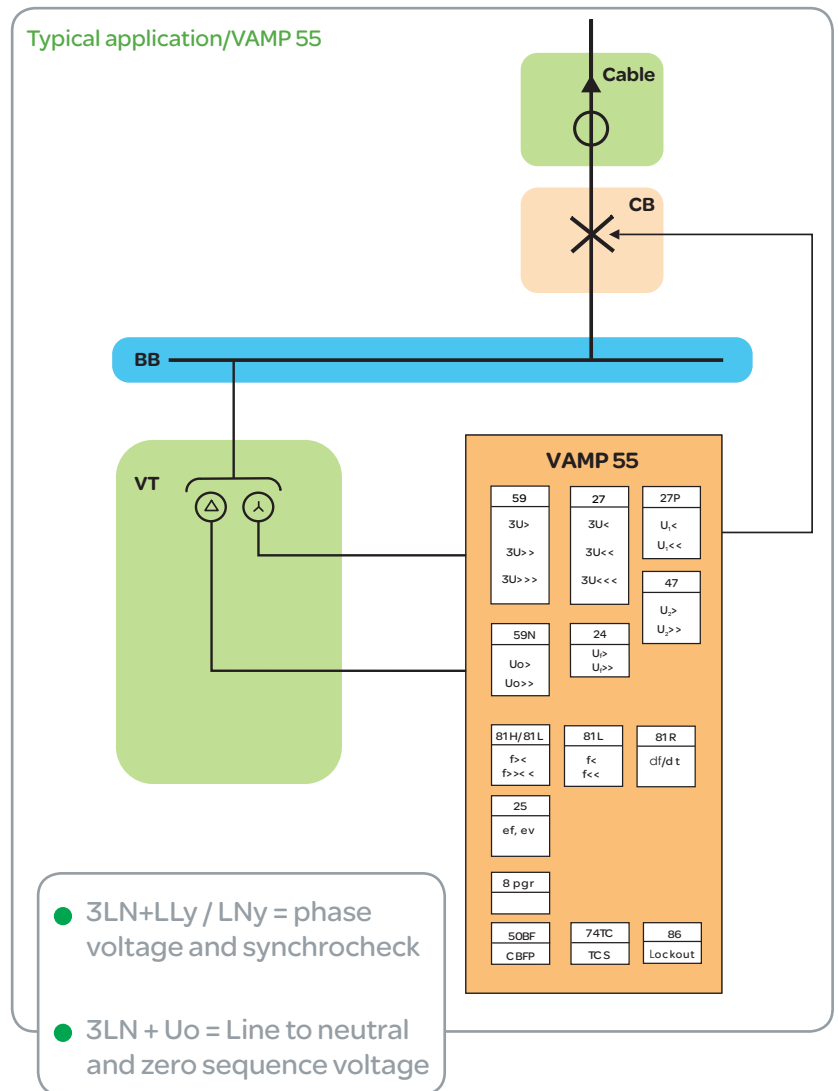

- 3LN+LLy / LNy = phase voltage and synchrocheck
- 3LN + U<sub>0</sub> = Line to neutral and zero sequence voltage



VAMP 55 CONNECTION DIAGRAM

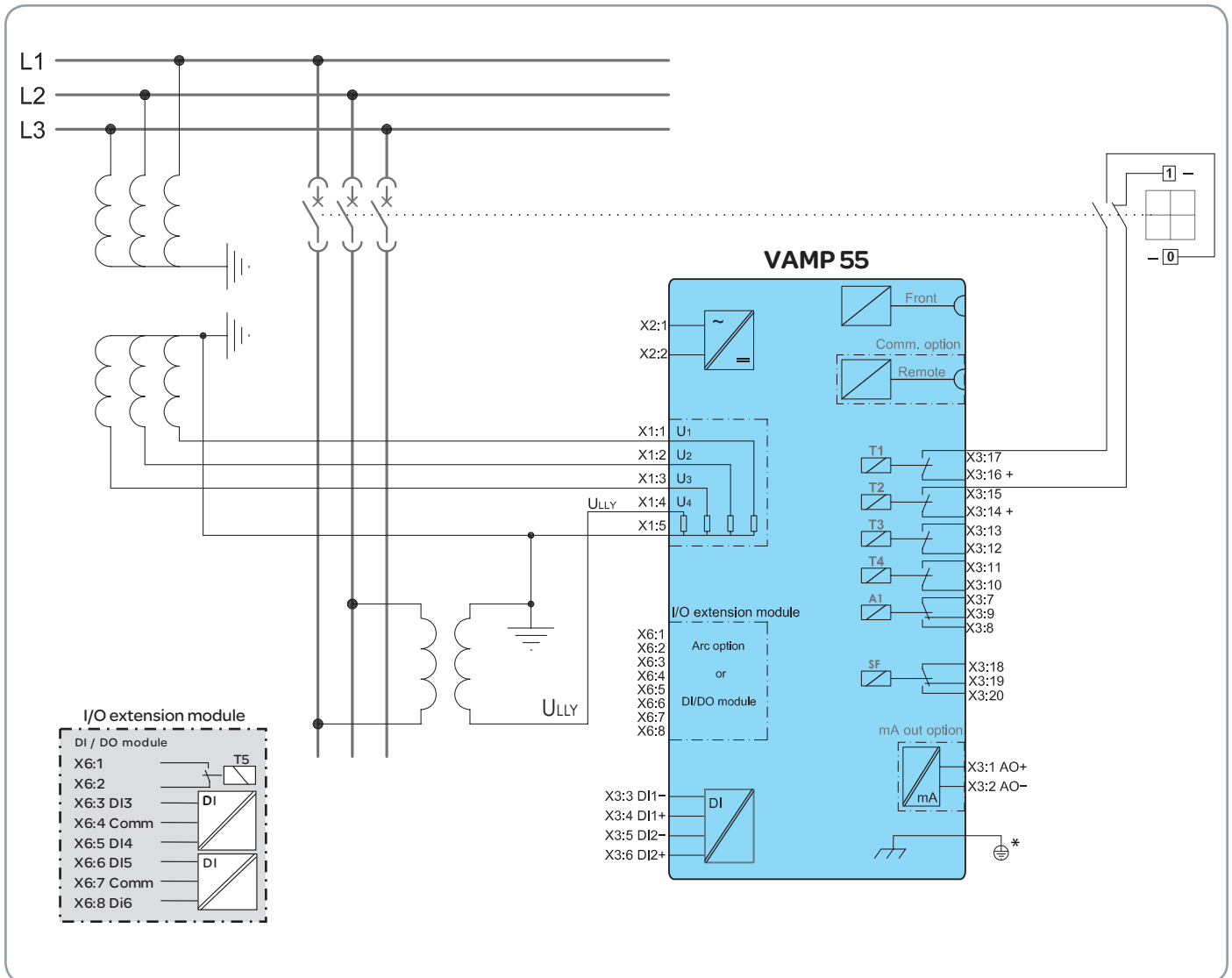

# VAMP 59 line differential relay



The Vamp 59 is designed for the protection of medium voltage overhead lines and cables. Versatile firmware enables this relay to also be used in applications with in-zone transformers. The relay includes back-up protection functions for basic overcurrent and earth fault functions with three phase autoreclose.

Further information can be found in the dedicated Vamp 59 product brochure.

# Dimensional drawings

## DEFAULT MODEL VAMP 50

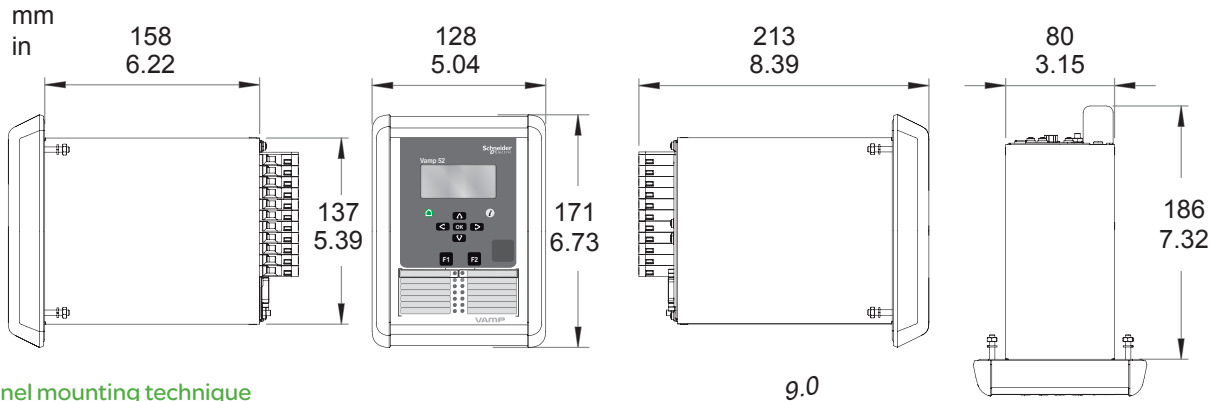

## Panel mounting technique

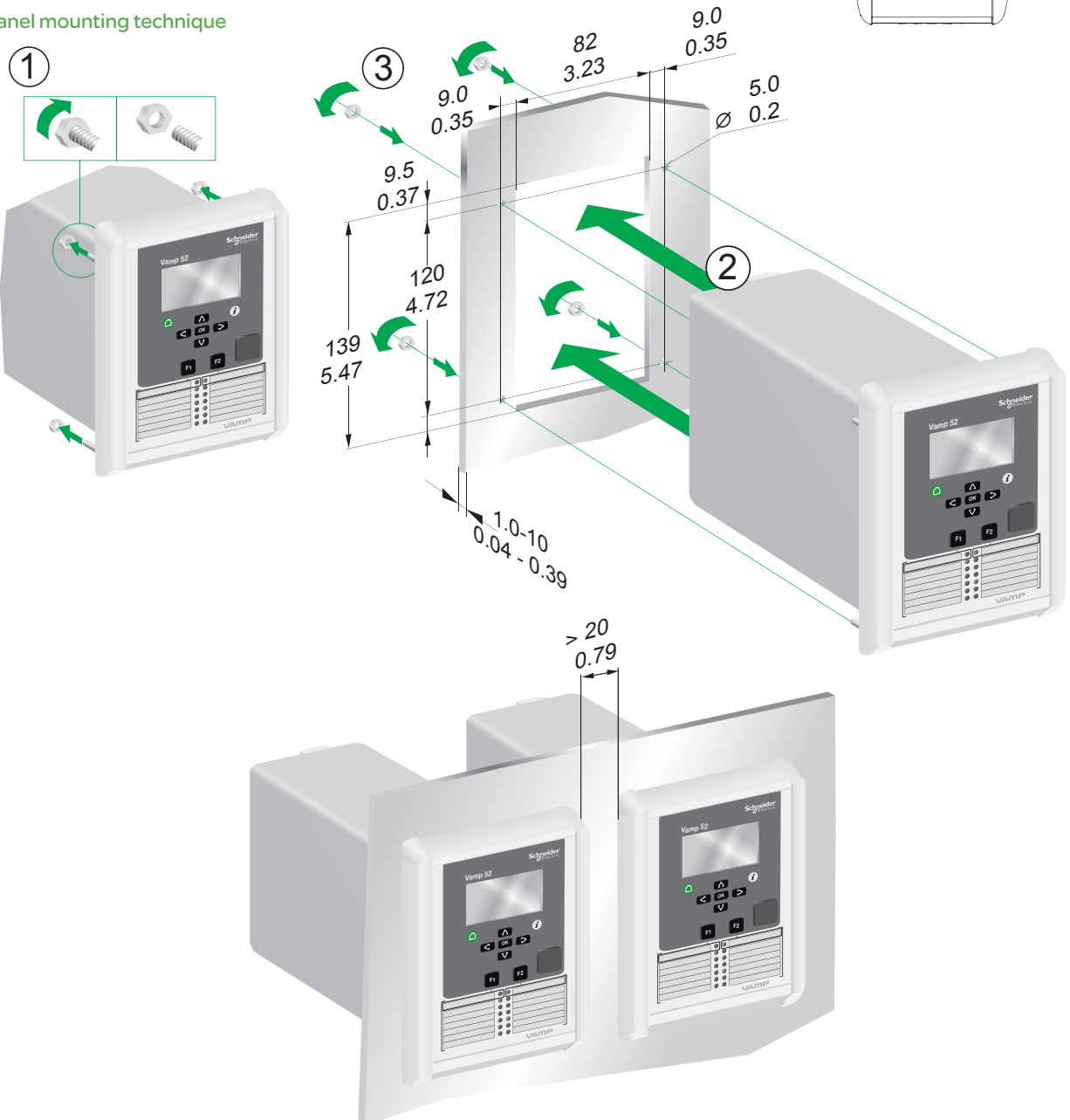

### VAMP 50S PANEL MOUNTING

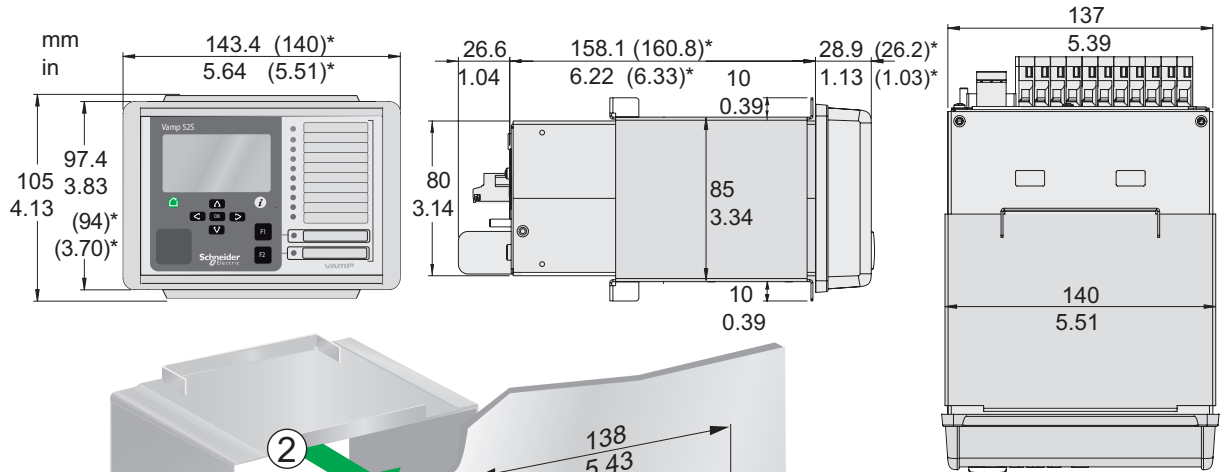

\* Without panel gasket

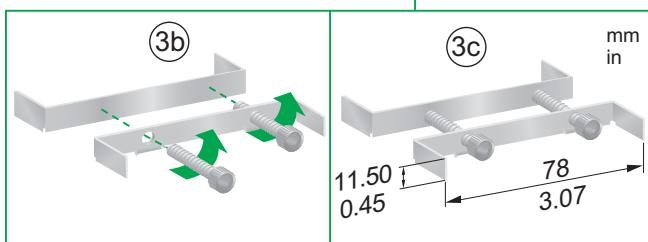
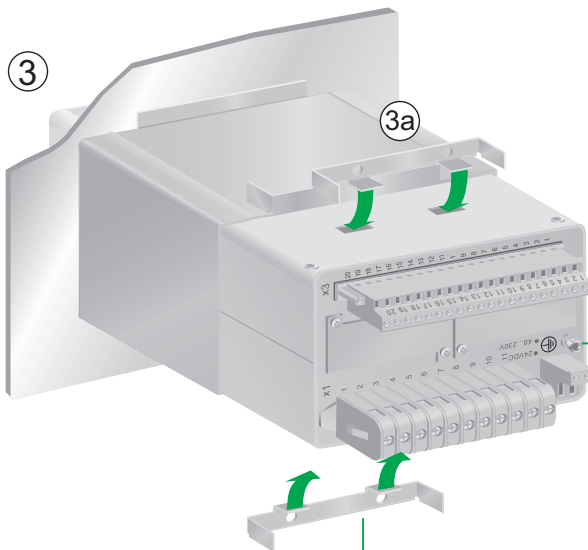
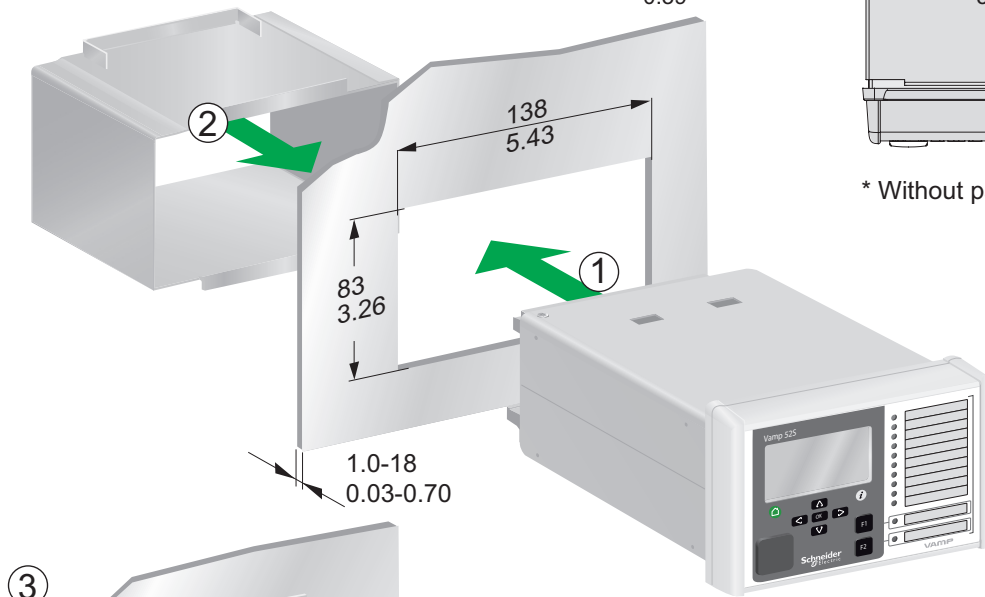

# Main technical data

Auxiliary voltage	
Voltage range	40...265 V ac / dc (option A) 18...36 V dc (option B)

Measuring circuit	
Rated phase current $I_N$	1A/5A
Current measuring range	0.005...50 x $I_N$
Rated neutral current $I_{ON}$	1 A or 5 A (optionally 0.2 A or 1 A)
Current measuring range	0.003...10 x $I_N$
Thermal withstand	4 x $I_N$ (continuous) 100 x $I_N$ (for 1 s)
Rated frequency $f_N$	50 / 60 Hz (45..65 Hz)

I/O	
Digital inputs (external voltage)	2 pcs (7 option)
Selectable nominal voltage (threshold)	24 / 110 / 220 V ac / dc
Trip contacts	4 pcs (5 option)

## Disturbance tests

	Standard & Test class / level	Test value
<b>Emission</b>	EN 61000-6-4 / IEC 60255-26	
Conducted	EN 55011 class A / IEC 60255-25	0.01 - 30 MHz
Emitted	EN 55011 class A / IEC 60255-25 / CISPR 11	30 - 1 000 MHz
<b>Immunity</b>	EN 61000-6-2 / IEC 60255-26	
1Mhz damped oscillatory wave	IEC 60255-22-1	± 2.5kVp CM, ± 1kVp DM
Static discharge (ESD)	EN 61000-4-2 class IV / IEC 60255-22-2	8 kV contact, 15 kV air
Fast transients (EFT)	EN 61000-4-4 class IV / IEC 60255-22-4 class A	14 kV / (12 kV signal ports), 5/50 ns, 5 kHz
Surge	EN 61000-4-5 class III / IEC 60255-22-5	2 kV, 1.2/50 ms, CM 1 kV, 1.2/50 ms, DM
Conducted HF field	EN 61000-4-6 class III / IEC 60255-22-6	0.15 - 80 MHz, 10 Vemf
Emitted HF field	EN 61000-4-3 class III / IEC 60255-22-3	80 - 2700 MHz, 10 V/m
Voltage interruptions	EN 61000-4-29 / IEC 60255-11	30%/1s, 60%/0.1s, 100%/0.05s
Voltage alternative component	EN 61000-4-17 / IEC 60255-11	12% of operating voltage (DC) / 10min
Voltage dips and short interruptions	EN 61000-4-11	30%/10ms, 100%/10ms, 60%/100ms >95%/5000ms
Power-frequency magnetic field	EN 61000-4-8	300A/m (continuous), 1000A/m / 1-3s
Pulse magnetic field	EN 61000-4-9	1000A/m, 1.2/50 ms

## Electrical safety tests

	Standard & Test class / level	Test value
Impulse voltage withstand	EN 60255-5, class III	5 kV, 1.2/50 ms, 0.5 J
Dielectric test	EN 60255-5, class III	2 kV, 50 Hz
Insulation resistance	EN 60255-5	
Protective bonding resistance	EN 60255-27	
Power supply burden	IEC60255-1	



## Mechanical tests

	Standard & Test class / level	Test value
<b>Device in operation</b>		
Vibrations	IEC 60255-21-1, class II / IEC 60068-2-6, Fc	1Gn, 10Hz – 150 HZ
Shocks	IEC 60255-21-2, class II / IEC 60068-2-27, Ea	10Gn/11ms
<b>Device de-energized</b>		
Vibrations	IEC 60255-21-1, class II / IEC 60068-2-6, Fc	2Gn, 10Hz – 150 HZ
Shocks	IEC 60255-21-2, class II / IEC 60068-2-27, Ea	30Gn/11ms
Bump	IEC 60255-21-2, class II / IEC 60068-2-27, Ea	20Gn/16ms

## Environmental conditions

	Standard & Test class / level	Test value
<b>Device in operation</b>		
Dry heat	EN / IEC 60068-2-2, Bd	+65°C
Cold	EN / IEC 60068-2-1, Ad	-40°C
Damp heat, cyclic	EN / IEC 60068-2-30, Db	From +25°C to +40°C, From 93% RH to 98% RH, 6 days
Damp heat, static	EN / IEC 60068-2-78, Cab	+40°C, 93% RH, 10 days
Flowing mixed gas corrosion test, method 2	IEC 60068-2-60, Ke	+25°C, 75% RH, 10 ppb H <sub>2</sub> S, 200 ppb NO <sub>2</sub> , 10 ppb CL <sub>2</sub>
Flowing mixed gas corrosion test, method 4	IEC 60068-2-60, Ke	+25°C, 75% RH, 10 ppb H <sub>2</sub> S, 200 ppb NO <sub>2</sub> , 10 ppb CL <sub>2</sub> , 200 ppb SO <sub>2</sub>
<b>Device in storage</b>		
Dry heat	EN / IEC 60068-2-2, Bb	+75°C
Cold	EN / IEC 60068-2-1, Ad	-40°C

## Casing

	Standard & Test class / level
Degree of protection (IEC 60529)	IP54
Dimensions (W x H x D)	130 x 170 x 210 mm
Material	1 mm steel plate
Weight	2.0 kg
Colour code	RAL 7032 (Casing) / RAL 7035 (Back plate)

## Package

	Standard & Test class / level
Dimensions (W x H x D)	260 x 160 x 215 mm
Weight (Terminal, Package and Manual)	2.4 kg

# Order codes



Relay type	
0	Overcurrent & earth fault relay
2	Feeder and motor protection relay
5	Voltage protection relay



Default model



Slimline model (S)

V50 or V52	V55
<b>Relay type</b>	<b>Relay type</b>
= Default	= Default
S = Slim line	S = Slim line
<b>Phase current inputs [A]</b>	<b>Nominal voltage [V]</b>
3 = 5 A	4 = 50...400 V (default size)
<b>Earth-fault current input [A]</b>	<b>X = None</b>
A = 1 A / 5 A	
B = 0.2 A / 1A	
<b>Supply Voltage [V]</b>	<b>Supply Voltage [V]</b>
A = 40... 265 Vac / dc	A = 40... 265 Vac / dc
B = 18 ... 36 Vdc	B = 18 ... 36 Vdc
<b>mA output option</b>	<b>mA output option</b>
A = None	A = None
B = mA output	B = mA output
<b>DI nominal activation voltage</b>	<b>DI nominal activation voltage</b>
1 = 24 Vdc / 110 Vac	1 = 24 Vdc / 110 Vac
2 = 110 Vdc / 220Vac	2 = 110 Vdc / 220Vac
3 = 220 Vdc	3 = 220 Vdc
<b>Optional I/O extension modules</b>	<b>Optional I/O extension modules</b>
A = None ***	A = None
B = Digital I/O; 4 x DI, 1 x DO	B = Digital I/O; 4 x DI, 1 x DO
C = Arc (2 x Arc sensor + BIO)	
D = Advanced arc (3 x Arc sensor + BIO)***	
<b>Optional communication module 1</b>	<b>Optional communication module 1</b>
A = None	A = None
D = Plastic / Plastic serial fibre interf.	D = Plastic / Plastic serial fibre interf.
E = Glass/Glass serial fibre interf.	E = Glass/Glass serial fibre interf.
F = Rx Plastic / Tx Glass serial fibre interf.	F = Rx Plastic / Tx Glass serial fibre interf.
G = Rx Glass / Tx Plastic serial fibre interf.	G = Rx Glass / Tx Plastic serial fibre interf.
K = K = RJ-45 10Mbps ethernet interf. inc IEC 61850	K = K = RJ-45 10Mbps ethernet interf. inc IEC 61850
P = Profibus interface	P = Profibus interface
R = 2 x ST 100Mbps ethernet fibre interface, inc. IEC 61850 !!	R = 2 x ST 100Mbps ethernet fibre interface, inc. IEC 61850 !!
S = 2 x RJ-45 100Mbps ethernet interf. inc. IEC 61850	S = 2 x RJ-45 100Mbps ethernet interf. inc. IEC 61850
B = RS 485 interface (2-wire) with option for module 2	B = RS 485 interface (4-wire) with option for module 2
L = RS232 interface with option for module 2	L = RS232 interface with option for module 2
M = RS-232 interface with option for module 2 and ext I/O + IRIG B	M = RS-232 interface with option for module 2 and ext I/O + IRIG B
<b>Optional communication module 2</b>	<b>Optional communication module 2</b>
A = None	A = None
B = IRIG-B timesyncro. input **	B = IRIG-B timesyncro. input **
C = RTD interface (Glass fibre) **	C = RTD interface (Glass fibre) **
E = RJ-45 10 Mbps ethernet interf. inc. IEC 61850 **	E = RJ-45 10 Mbps ethernet interf. inc. IEC 61850 **
G = LC 100 Mbps ethernet fibre interf. inc. IEC 61850 **	G = LC 100 Mbps ethernet fibre interf. inc. IEC 61850 **
<b>PCP coating</b>	<b>PCP coating</b>
= Default	= Default

**Note:**

\*\* Option available only with communication module 1: B and L

!! Supply voltage has to be 110 Vac/dc or more. Check out our website for DualPortEthernetInterface\_AppNote\_006".

## ACCESSORIES

Order code	Description	Note
VX052-3	USB programming cable (Vampset)	Cable length 3 m
VX054-3	Interface cable to VPA 3 CG (Profibus module) for RS 232	Cable length 3 m
VX044	Interface cable to VIO 12 (RTD module)	Cable length 2 m
VSE001PP	Fibre optic Interface Module (plastic - plastic)	Max. distance 1 km
VSE001GG	Fibre optic Interface Module (glass - glass)	Max. distance 1 km
VSE001GP	Fibre optic Interface Module (glass - plastic)	Max. distance 1 km
VSE001PG	Fibre optic Interface Module (plastic - glass)	Max. distance 1 km
VSE002	RS485 module	
VPA3CG	Profibus DP fieldbus option board	Requires external power module, to be used when both ethernet and profibus communications are needed
VIO 12 AA	RTD Module, 12pcs RTD inputs, Optical Tx Communication (24-230 Vac/dc)	
VIO 12 AB	RTD Module, 12pcs RTD inputs, RS 485 Communication (24-230 Vac/dc)	
VIO 12 AC	RTD/mA Module, 12pcs RTD inputs, PTC, mA inputs/outputs, RS232, RS485 and Optical Tx/Rx Communication (24 Vdc)	
VIO 12 AD	RTD/mA Module, 12pcs RTD inputs, PTC, mA inputs/outputs, RS232, RS485 and Optical Tx/Rx Communication (48-230 Vac/dc)	
VA 1 DA-6	Arc Sensor	Cable length 6 m
VA 1 DA-20	Arc Sensor	Cable length 20 m
V50WAF	V50 wall assembly frame	



### DEVICE TRACK RECORD

- Schneider Electric's VAMP range specialises in protection relays, arc flash protection and measuring and monitoring units for power systems.
- VAMP's medium-voltage and sub-transmission protection relays are used in numerous applications, from overhead line feeders and substations to power plants and industrial power system. Their unique integrated arc flash fault protection functionality enhances the safety of both people and property and has made VAMP a leading range in arc flash protection worldwide. VAMP products meet the latest international standards and regulations.

#### Schneider Electric Industries SAS

35, rue Joseph Monier  
CS 30323  
F - 92506 Rueil Malmaison Cedex (France)  
Tel.: +33 (0) 1 41 29 70 00  
RCS Nanterre 954 503 439  
Capital social 896 313 776 €  
[www.schneider-electric.com](http://www.schneider-electric.com)

As standards, specifications and designs change from time to time, please ask for confirmation of the information given in this publication.

Design: Schneider Electric Industries SAS - Sonovision  
Photos: Schneider Electric Industries SAS  
Printed in Finland



*This document has been printed on recycled paper.*